

User Guide

Eclipse 15.0 HX Installation Guide



Part Number: PUB-00373 Rev A

Date: June 05, 2026

Table of contents

1 Important Safety Instructions	5
2 Installation Overview	7
2.1 Before Installing the System	7
2.2 Installing the Eclipse HX System	11
2.3 After Installing the Eclipse HX System	14
3 Locating System Components	19
3.1 Locating Eclipse HX Matrices	19
3.2 Locating Interface Frame(s) and Power Supplies	21
3.3 Locating User Panels	23
3.4 Locating the External Computer for EHX	23
4 Powering System Components	25
4.1 Powering Matrices	25
4.2 Powering User Panels	26
4.3 Powering Interface Frames	27
5 Wiring System Components	30
5.1 Using RJ-45 Connectors	30
5.2 Connecting the Matrix to a PC Running EHX	33
5.3 Connecting the Matrix to an Ethernet Network	36
5.4 Connecting the Matrix to a PC Running Dynam-EC	37
5.5 Connecting the Matrix to User Panels	38
5.6 General Purpose Outputs (GPOs)	39
5.7 General Purpose Inputs (GPIs)	42
5.8 E & M Signalling with an E-QUE E1 / T1 Interface Card	47
5.9 Connecting the Matrix to an External Alarm	51
5.10 Connecting to a Four-Wire Audio Device	53
5.11 Connecting to Interface Modules	53
6 Connecting Matrices	73
6.1 Intelligent Linking	73
6.2 Linking Eclipse HX-Pico Matrices with the PiCo-Link	77

6.3 Tie-Line (Audio Only) Linking	78
6.4 E1 / T1 Linking	78
6.5 Fiber-Optic Linking	83
7 Glossary	86
8 Limited Warranty	91
8.1 Warranty Period	91
8.2 Technical Support	91
8.3 Warranty Repairs and Returns	92
8.4 Non-Warranty Repairs and Returns	93
8.5 Extended Warranty	93
8.6 Service Contract	93
8.7 Liability	94

Document reference

Eclipse HX Matrix Installation Guide

Part Number: PUB-00373 Rev A

Legal disclaimers

Copyright © 2026 HME Clear-Com Ltd

All rights reserved

Clear-Com and the Clear-Com logo are trademarks or registered trademarks of HM Electronics, Inc.

The software described in this document is furnished under a license agreement and may be used only in accordance with the terms of the agreement.

The product described in this document is distributed under licenses restricting its use, copying, distribution, and decompilation / reverse engineering. No part of this document may be reproduced in any form by any means without prior written authorization of Clear-Com, an HME Company.

Clear-Com Offices are located in California, USA; Cambridge, UK; Dubai, UAE; Montreal, Canada; and Beijing, China. Specific addresses and contact information can be found on Clear-Com's corporate website: www.clearcom.com

Clear-Com contacts

Americas and Asia-Pacific Headquarters

California, United States

Tel: +1 510 337 6600

Email: SalesSupportUS@clearcom.com

Europe, Middle East, and Africa Headquarters

Cambridge, United Kingdom

Tel: +44 1223 815000

Email: SalesSupportEMEA@clearcom.com

China Office

Beijing Representative Office

Beijing, P.R. China

Tel: +8610 59000198/59002608

Email: SalesSupportChina@Clearcom.com

1 Important Safety Instructions

1. Read these instructions.
2. Keep these instructions.
3. Heed all warnings.
4. Follow all instructions.
5. Do not use this apparatus near water.
6. Clean only with dry cloth.
7. Do not block any ventilation openings. Install in accordance with the manufacturer's instructions.
8. Do not install near any heat sources such as radiators, heat registers, stoves, or other apparatus (including amplifiers) that produce heat.
9. Do not defeat the safety purpose of the polarized or grounding-type plug. A polarized plug has two blades, with one wider than the other. A grounding-type plug has two blades and a third grounding prong. The wide blade or the third prong are provided for your safety. If the provided plug does not fit into your outlet, consult an electrician for replacement of the obsolete outlet.
10. Protect the power cord from being walked on or pinched particularly at plugs, convenience receptacles, and the point where they exit from the apparatus.
11. Only use attachments/accessories specified by the manufacturer.
12. Use only with the cart, stand, tripod, bracket, or table specified by the manufacturer, or sold with the apparatus. When a cart is used, use caution when moving the cart/apparatus combination to avoid injury from tip-over.
13. Unplug this apparatus during lightning storms or when unused for long periods of time.
14. Refer all servicing to qualified service personnel. Servicing is required when the apparatus has been damaged in any way, such as power-supply cord or plug is damaged, liquid has been spilled or objects have fallen into the apparatus, the apparatus has been exposed to rain or moisture, does not operate normally, or has been dropped.
15. **WARNING:** To reduce the risk of fire or electric shock, do not expose this product to rain or moisture.

Please familiarize yourself with the safety symbols in the image below. When you see these symbols on this product, they warn you of the potential danger of electric shock if the main station is used improperly. They also refer you to important operating and maintenance instructions in the manual.

EMC AND SAFETY

This Product's power supply meets all relevant CE, FCC, UL, and CSA specifications set out below:

EN55103-1 Electromagnetic compatibility. Product family standard for audio, video, audio-visual, and entertainment lighting control apparatus for professional use. Part 1: Emissions.

EN55103-2 Electromagnetic compatibility. Product family standard for audio, video, audio-visual, and entertainment lighting control apparatus for professional use. Part 2: Immunity.

UL 60065-7, CAN/CSA-C22.2 No.60065-3, IEC 60065-7 Safety requirements.

And thereby compliance with the requirement of Electromagnetic Compatibility Directive 2004/108/EC and Low Voltage Directive 2006/95/EC

This device complies with Part 15 of the FCC Rules. Operation is subject to the following two conditions: (1) this device may not cause harmful interference, and (2) this device must accept any interference received, including interference that may cause undesired operation.

2 Installation Overview

This section provides a basic overview of the installation process for an Eclipse HX system. This system comprises:

- An **Eclipse HX matrix** or **Eclipse HX-Delta-Lite** (either the 6RU **Eclipse HX-Median** or **Eclipse HX-Omega** or the 3RU **Eclipse HX-Delta** matrices, or the 1RU **Eclipse HX-PiCo** matrix).
- An external computer (PC), which hosts the **Eclipse HX (EHX) configuration software**.
- **Interface modules**, which enable connections with a wide range of intercom systems, from analog and digital intercom systems, to wireless systems and telephone networks.
- **Interface frames**, which are used to host interface modules.
- **User Panels, V-Series , I-Series and 2X10 Touch Desktop panel**.

***Note:** This section is designed for general guidance only. For more detailed information about individual system components, and how to connect them (including wiring schemes), see the rest of this guide.*

2.1 Before Installing the System

2.1.1 Check the Shipment

When you receive your Eclipse HX matrix system components:

- Inspect the boxes for shipping damage. Report any shipping damage to the carrier.
***Note:** The Eclipse matrix system distributor is **not** responsible for shipping damage.*
- Check that every item on the packing list has been received.
- Check that auxiliary options have been fitted to system components (such as V-Series panels and I-Series panels).

***Note:** Auxiliary options may also include interface cards (sometimes called expansion cards or intercom panels) for the Eclipse HX-Omega, Eclipse HX-Median and Eclipse HX-Delta matrices. The names of interface cards are displayed on the front and rear cards in each set.*

- Save all packing materials (boxes, Styrofoam). If any item has been shipped in error, is malfunctioning, or requires warranty service, use the original packing materials to return that item to Clear-Com.

2.1.2 Select Locations for the System Components

Select locations for the Eclipse HX matrix, interface cards, interface modules, user panels, PC, and any other system components.

The Eclipse HX matrix is the **central connecting point** of the system. All other devices are connected, either directly or indirectly, to the matrix, and this central role must be accounted for in your system topography.

Note: For additional information about locating the Eclipse HX matrix system, see [Locating System Components](#).

2.1.3 Determine Cabling and Wiring Scheme Requirements

The Eclipse HX system requires **shielded category-5 (CAT5) cable with RJ-45 connectors**. All Eclipse matrices have built-in RJ-45 connectors.

Wiring schemes

Different wiring schemes are required, depending on the intercom device / system component that is being connected.

For example:

System component	Connections
External computer (PC) for EHX	<p>The Eclipse HX configuration software runs on an external computer (PC). The computer is normally connected to the matrix using the LAN1 connector (a standard RJ-45 Ethernet connector).</p> <p>For Eclipse HX-Omega, Eclipse HX-Median and Eclipse HX-PiCo, a ferrite core must be added to the socket end of each Ethernet cable to comply with European EMC standards. A suitable ferrite core is Würth Elektronik part: 74271132.</p> <p>Shielded CAT5 cable is recommended for Electro Magnetic Compliance in EC countries.</p> <p>Note: LAN1 is the default connector on the matrix. The LAN2 connector (which is also a standard RJ-45 Ethernet connector) is unconfigured when it leaves the factory and must be enabled in EHX before it can be used.</p> <p>Tip: Connecting through an Ethernet network enables one or more matrices to be controlled through one or more computers on a network. You can also use the supplied DB-9 cable or a commercially available shielded RS-232 cable. For more information, see Connecting the Matrix to a PC Running EHX.</p> <p>Note: The Eclipse HX-Pico uses a special null modem DB9 to 3.5 TRS. The HX-Median / HX-Omega /HX-Delta CPU card uses a straight serial cable.</p> <p>If the EHX computer does not have a serial port, but only provides USB connectors, adapters are available from computer parts suppliers. However, you will be required to install drivers for USB-to-serial port connections.</p> <p>Important note: Because of compatibility issues with some products, Clear-Com does not recommend the use of USB-to-serial port connections.</p>

System component	Connections
User panels (V-Series, I-Series user panels and 2X10 Touch Desktop panel)	<p>An analog connection, using shielded CAT5 4-twisted pair cables with RJ-45 connectors, is the most common way of connecting V-Series user panels and I-Series panels to the matrix.</p> <p>You can use the following alternative methods for connecting V-Series panels:</p> <p>A digital connection, using the AES-6 digital interface module. Coaxial cable is required to connect panels to the AES-6CX rear card.</p> <p>An IP-based connection, using the E-IPA or IVC-32 interface card (fitted to an HX-Median, HX-Omega or HX-Delta matrix). The E-IPA or IVC-32 interface card allows the Eclipse HX matrix to connect to IP enabled V-Series panels over existing WAN / LAN Ethernet cabling infrastructure. V-Series panels can also optionally support up to two additional IP channels. For more information, see the V-Series Panel User Guide.</p> <p>The E-IPA or IVC-32 card can add IP connections through an Ethernet switch / router linked to the Ethernet network. For more information about the E-IPA or IVC-32 card, see the Eclipse HX-Omega, Eclipse HX-Median or Eclipse HX-Delta User Guide.</p> <p><i>Note: For each user panel, additional connector wiring may be required, depending on the options and accessories installed. See Wiring System Components and the user manual for your panel.</i></p>
Interface modules	<p>Interface modules are connected to the matrix using:</p> <ul style="list-style-type: none"> • Particular wiring schemes (for each module type) on the DB-9 connectors on the rear of the associated interface frame (IMF-3). • Shielded CAT5 4-twisted pair cables with RJ-45 connectors. <p>The RLY-6 and GPI-6 interface modules are connected directly using an RJ-45 connector on the rear of the matrix to the appropriate interface input connector on the interface frame (IMF-3).</p> <p>For more information, see Connecting to Interface Modules.</p>

System component	Connections
External alarm	<p>Eclipse HX matrices have built-in fault alarm systems.</p> <p>If you want to use an additional remote alarm, relay contacts are available on the rear panel of the matrix.</p> <p>If you want to add an external alarm condition to the matrix alarm system, the same connector on the rear panel alarm I/O will permit an external contact closure to be connected to the matrix alarm system.</p> <p>Shielded cable is recommended for Electro Magnetic Compliance in EC countries.</p>

Note: For more information about RJ-45 connectors and their installation, see [Locating System Components](#).

For detailed information about wiring schemes, see [Wiring System Components](#).

For more detailed information about the range of interface cards that can be installed to 6RU matrices, see the:

- *Eclipse HX-Omega User Guide.*
- *Eclipse HX-Median User Guide.*
- *Eclipse HX-Delta User Guide.*

2.2 Installing the Eclipse HX System

2.2.1 Installing the Matrix in a 19" Rack

Install the matrix in a standard Electronics Industry Association 19-inch wide (48.26 cm) equipment rack. Clear-Com recommends installing the matrix to the **center portion** of the rack, allowing easy access to the connectors on the rear of the matrix.

Because of the large number of cables connected to the matrix, you should also plan for the dressing of cables.

Environmental information

The matrix requires adequate ventilation. Leave at least **2 inches (50.8 mm)** of clearance on all sides of the matrix to ensure proper airflow. Do not block ventilation vents.

Check the position of the circuit cards (CPU cards and interface cards), power supplies, and rear connector panels.

Note: For detailed information about installing a particular matrix or interface frame in the rack, see the appropriate guide in the Eclipse HX documentation set. For matrices, see the:

- **Eclipse HX-Omega User Guide.**
- **Eclipse HX-Median User Guide.**
- **Eclipse HX-Delta User Guide.**
- **Eclipse HX-PiCo User Guide.**

For interface frames, see your **IMF-3** or **IMF-102** documentation.

2.2.2 System Limits

The following limits apply when installing cards in an Omega, Median or Delta matrix:

- IVC-32, E-Que and LMC-64 cards are high-power devices, and you can only install a total of four of these cards in an Eclipse Median or Delta frame.
- In an Eclipse Omega frame that is fitted with a Power-One PSU, you can install up to a total of seven E-IPA cards if installed in ambient temperature that does not exceed 85°F (+30°C). In this case, you are recommended to install a fan tray. Without any E-IPA cards, you cannot install more than six antenna/splitter E-Que cards, or more than four E-Que cards with EM Signalling enabled. For more information about the Power-One PSU, including part number see the **Power Supplies** section in the *Eclipse HX Omega User Guide*.

This is summarized in the table below:

Card	Maximum number with Power-One PSU (720379Z)	Maximum number with other PSU
IVC-32	6	4
LMC-64	6	4
E-Que antenna/splitter	4	4
E-Que with EM signalling enabled	4	4
E-Que other	6	4

If you attempt to add an E-IPA high-power card to a matrix that already has the maximum number installed, a warning displays in EHX software.

2.2.3 Installing the Cabling

Install the intercom cables between the Eclipse HX matrix and the other system components (user panels and interface frames).

Clear-Com recommends that you route cables **before** wiring the connectors to the cables.

Note: For more information about routing cables, see [Locating System Components](#).

2.2.4 Connecting System Components to the Matrix

Connect the system components / devices (such as the external computer for EHX, interface frames and modules, and external alarms) to the matrix.

For a wiring scheme / connection overview, see [Determine Cabling and Wiring Scheme Requirements](#).

Note: For detailed information about wiring schemes, see [Wiring System Components](#).

2.2.5 Connecting to Mains AC Power

Eclipse HX matrices and interface frames (IMF-3)

Eclipse HX matrices have two separate AC power connectors for two separate power supplies in the system. Either power supply will completely power a system, providing 100% power redundancy. If the two power supplies are connected to different AC power sources and one of the power supplies loses power, the other will continue to operate the system.

AC voltage for the matrices and the **PSU-101** can be **100 - 240 VAC** without any switching or fuse changes.

Each component of the Eclipse HX system requires AC power **except** for the IMF-3 and some interface modules. The IMF-3 requires an external power supply. The XP-type expansion panels receive power from the panels to which they are connected.

If you are installing an IMF-3, install the **DC power cables** that connect the power supply to the matrix. For the matrix and each connected component, install and connect the mains AC power cables.

Note: For further information, see [Powering System Components](#).

V-Series panels

Each V-Series panel has an external power supply and a removable cradle to hold the external power supply.

AC voltage for these panels can be **100 - 240 VAC** without any switching or fuse changes.

I-Series panels

I-Series panels have internal power supplies, with removable AC power cords. The power supplies are universal, operating over a voltage range of 90 - 245 VAC and **50 - 60 Hz**. The maximum dissipation is **40 W**.

2X10 Touch Desktop panel)

The 2X10 Touch Desktop panel has a 2.5mm Power jack connector with screwlock retention to accept the required input power of 12VDC, 2A.

An AC/DC Desk Top Power Adapter is supplied with the unit. The power adapter has the following specification:

- Input connector : IEC-320 C14 male receptacle
- Input AC Voltage range : 100-240VAC
- Input Frequency range : 50-60Hz
- Input current : 1.2A
- Output DC Voltage : 12VDC
- Output rated current : 3.5A
- Output connection : 2.5mm DC power plug (with 1.5meters lead)

Note: Each panel must be plugged into an AC source at its location.



Only connect power supply to earthed supply sockets. Ensure that the power supply is routed to avoid sharp bends, hot surfaces, pinches and abrasion. Refer all servicing to qualified service personnel.

For more safety guidance, see the Safety Instructions supplied with this product.

2.3 After Installing the Eclipse HX System

2.3.1 Configuring the system with EHX software

The Eclipse HX (EHX) configuration software controls the operation of the connected audio devices by sending signals to the CPU and interface cards in the matrix, which then relay the signals to connected audio devices and systems.

Configurations (the operating parameters of complete system setups) are created in EHX.

Up to four complete system configurations can be stored in the CPU card of the Eclipse HX-Median, Eclipse HX-Omega, Eclipse HX-Delta or the CPU of the HX-PiCO. These configurations can be retrieved and activated on the matrix when required.

The external PC that hosts the EHX software can store an almost unlimited number of complete system configurations (the number is only limited by the available memory space on the PC). You can download the configurations to the matrix as required.

When running EHX on Windows operating systems, the client and server can run on separate machines connected over a network. You can use EHX to perform a wide range of configuration tasks, including:

- Assigning labels (names) to ports and user panels.
- Creating point-to-point and fixed group (partyline) communications between connected audio devices.
- Enabling, limiting or disabling features of any connected user panel or card.
- Configuring connections between matrices.

Note: *The above list is not definitive. For more information about the capabilities of EHX, see **EHX Help**.*

2.3.2 Recommended PC Requirements (for EHX Software)

Specification	Description / Value
Processor	2GHz or greater for a client. As many cores as possible for a server.
Memory	2GB for client 32 bit. 4GB for client 64 bit. 3GB for server 32 bit. 4GB+ for server 64 bit.
Free space	1GB minimum 32 bit. 2GB minimum 64 bit.
Display resolution	1600 x 1200

Specification	Description / Value
Operating systems	<p>EHX 8.5.1 runs on the following versions of Windows:</p> <p>Microsoft Windows 7 (32-bit and 64-bit).</p> <p>Microsoft Windows 8.1 (32-bit and 64-bit).</p> <p>Microsoft Windows 10 (32-bit and 64-bit).</p> <p>Microsoft Windows Server 2008 R2 (64-bit).</p> <p>Microsoft Windows Server 2012 R2 (64-bit).</p> <p>Operation on other platforms is no longer supported.</p>

2.3.3 Checking the Installed System

After configuring the Eclipse HX system, check that every system component is functioning correctly, including all:

- Control inputs, outputs and audio paths.
- Connections with connected external devices, such as interface modules and User Panels
- Software configuration functions, such as partylines, ISO and IFB functionality.

To assist with testing, the Eclipse HX system is delivered with a fully functional default EHX configuration. You can tailor the configuration, using EHX software, to meet the requirements of your particular installation.

Note: *Because each installation is different, it is beyond the scope of this guide to outline in detail all the checks that you must carry out.*

Checking the matrix

Eclipse HX-Omega, HX-Median and HX-Delta

The LEDs on the front of the CPU card indicate its operational status:

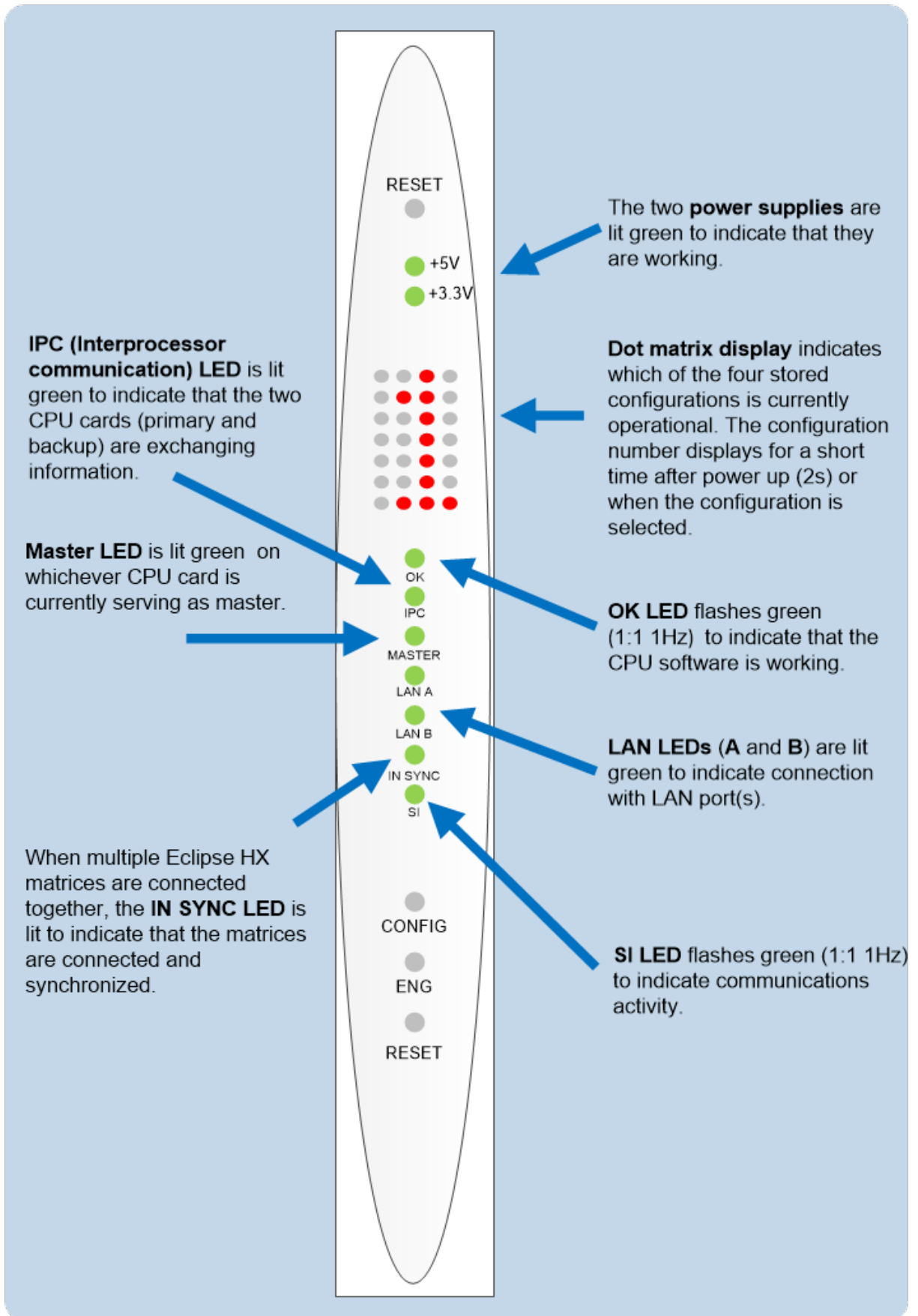

Note: For more information about the lights and controls on the CPU card, see either.

- *The Eclipse HX-Omega User Guide.*
- *The Eclipse HX-Median User Guide.*
- *The Eclipse HX-Delta User Guide*

Eclipse HX-PiCo

The LEDs on the front of the matrix indicate its operational status:

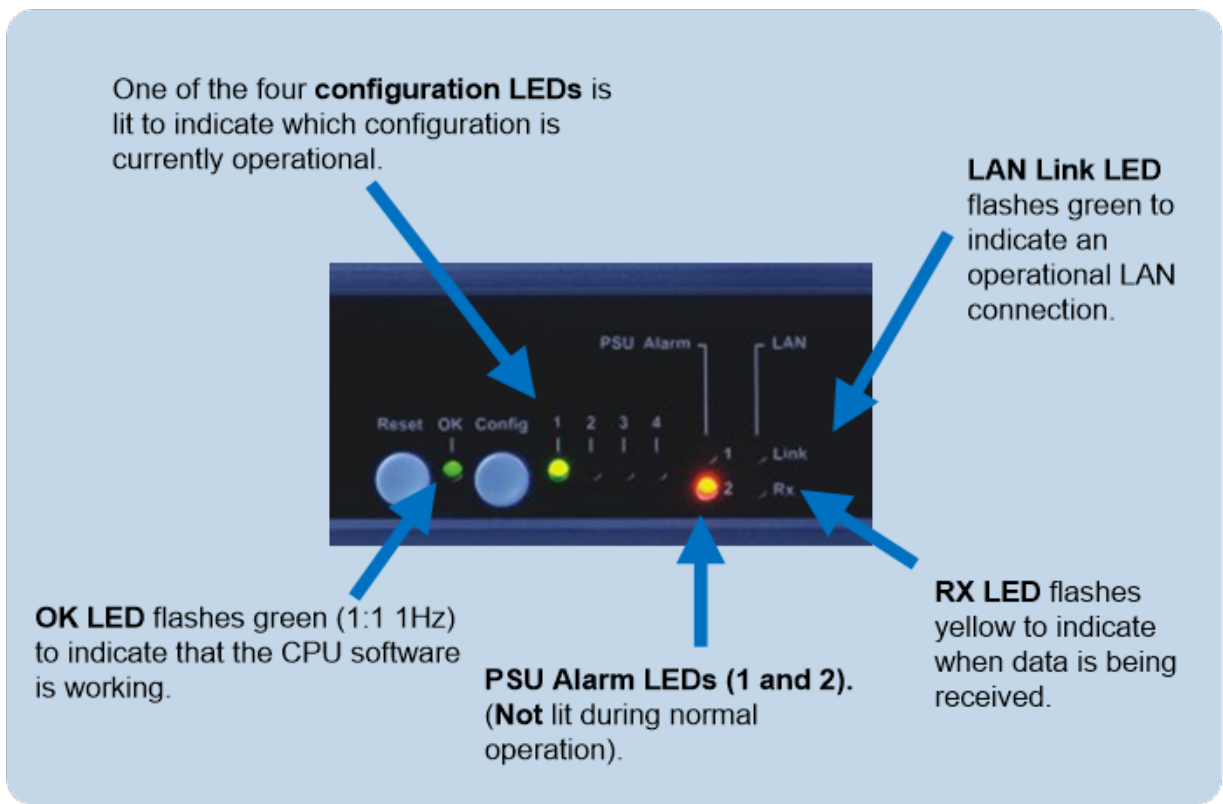

Note:

For more information about the lights and controls on the front of the Eclipse HX-PiCo, see the *Eclipse HX-PiCo User Guide*.

3 Locating System Components

This section provides help with deploying (locating and arranging) the principal components of your Eclipse HX system, including:

- Eclipse HX matrices (Eclipse HX-Omega, Eclipse HX-Median, Eclipse HX-Delta and Eclipse HX-PiCo).
- An external computer (for the EHX configuration software).
- Interface frame(s) (the IMF-3 and IMF-102), which host interface modules.
- User panels (V-Series, I-Series or 2X10 Touch Desktop panels).
- Power supplies.

Note: For an overview of the entire installation process, see [Installation Overview](#).

3.1 Locating Eclipse HX Matrices

The Eclipse HX matrices comprise the 6RU Eclipse HX-Omega and Eclipse HX-Median, the 3RU Eclipse HX-Delta, the Eclipse HX-Delta-Lite and the 1RU Eclipse HX-PiCo.

The Eclipse HX matrix is the **central connecting point** of the system. **All** other devices are connected, either directly or indirectly, to the matrix, and this central role must be accounted for in your deployment planning and cabling topography.

To allow easy access to connectors, ensure that you install the matrix to a central position in the standard **Electronics Industry Association 19-inch wide (48.26 cm) rack**. Because of the potentially large number of cables that may be connected to the matrix, some planning may also be necessary for dressing the cables.

Note: A rack unit (1RU) refers to a standardized unit of space in an Electronics Industry Association equipment rack. One rack unit is 1.75 inches high and 19 inches wide (44.45 mm by 482.6 mm). Each increasing rack unit (1RU) adds 1h.75 inches to the area vertically, while staying at 19 inches horizontally.

3.1.1 Locating the Eclipse HX-Omega, Eclipse HX-Median and Eclipse HX-Delta

The Eclipse HX-Omega and Eclipse HX-Median matrices each require **six vertical rack units (6RU)** (10.5 inches or 267 mm) in a standard Electronics Industry Association 19-inch wide (48.26 cm) rack. The Eclipse HX-Delta matrix requires **three vertical rack units (3RU)** (5.25 inches or 134 mm) in the same 19-inch rack.

Cooling the Omega / Median matrix

Each matrix has **two power supplies** (one for redundancy). A modular removable alarm module fitted beneath the two power supplies has two fans that deliver

forced air cooling. The primary fan runs continuously. If the temperature in the matrix exceeds a set threshold and extra cooling is required, a secondary fan switches on to increase the air flow in the matrix.

The **fan-on alarm LED** on the front of the alarm module illuminates **red** to indicate that the secondary fan is on. The **red fan-fail alarm LED** illuminates when either fan stops rotating correctly. These alarm LEDs allow the system operator to identify and correct the alarm conditions.

For more information, see the:

- *Eclipse HX-Omega User Guide.*
- *Eclipse HX-Median User Guide*

Environmental information:

- The air flow through a 6RU matrix from the bottom to the top **must** be unimpeded.
- If other equipment is mounted above and below the matrix that impedes the air flow through the matrix, it will be necessary to leave **1 RU of empty space** above and below the matrix to prevent over-heating.
- If the matrix is mounted in a portable case this air flow must not be impeded.

Cooling the Delta matrix

Each matrix has two external power supplies (one for redundancy). A modular removable fan/alarm module at the front of the unit has two fans that deliver forced air cooling. Both fans run continuously, but as the temperature increases, their speed increases to boost the air flow in the matrix.

The **fan fail alarm LEDs** illuminate if the corresponding fan stops rotating correctly. These alarm LEDs allow the system operator to identify and correct the alarm conditions.

For more information, see the *Eclipse HX-Delta User Guide*.

Environmental information:

- The air flow through an Eclipse HX-Delta, left to right, must not be impeded. The airflow in a standard 19-inch (48.26cm) rack should be sufficient. If the matrix is mounted in a portable case, ensure that the air flow is not impeded.

3.1.2 Locating the Eclipse HX-PiCo

The Eclipse HX-PiCo matrix requires **one vertical rack unit (1RU)** (1.75 in. or 44.45 mm) in a standard Electronics Industry Association 19-inch (48.26 cm) rack.

Cooling the matrix

A temperature-controlled fan cools the Eclipse HX-PiCo and forces air through the unit horizontally. An **alarm LED** on the front panel of the Eclipse HX-PiCo alerts the system operator when the temperature-controlled fan activates.

Environmental information:

- The air flow across an Eclipse HX-PiCo matrix must be unimpeded. The air flow in a standard 19-inch (48.26 cm) rack should be sufficient. If the matrix is mounted in a portable case, be sure the air flow is not impeded.

3.2 Locating Interface Frame(s) and Power Supplies

Interface modules convert the four-wire audio signals from the matrix into audio formats for telephones, camera intercoms, two-way radios, analog partyline systems, and other communication devices. In this way, non-four-wire devices can communicate with the matrix.

In addition to 7 slots for circuit cards (CPU and interface cards), the 6RU Eclipse HX-Median matrix has slots for up to 8 interface modules. The 3RU Eclipse HX-Delta matrix has 4 slots for circuit cards, and slots for up to 3 interface modules.

Clear-Com also offers two types of interface frame to host interface modules.

3.2.1 IMF-3 Interface Frame

The IMF-3 interface frame holds up to **11 interface modules in three rack units (3 RU)** of a standard Electronics Industry Association 19-inch wide (48.26 cm) rack.

The frame holds a rear connector panel for each interface module, comprising:

- Two RJ-45 connectors for connecting with the matrix.
- Two DB-9 connectors for connecting cable to non-four-wire devices (see the **IMF-3 rear panel** image below).

PSU-101 power supply for the IMF-3

The frame uses an **external PSU-101** rack-mounted power supply to supply power to the interface modules. A second PSU-101 can be attached for redundancy.

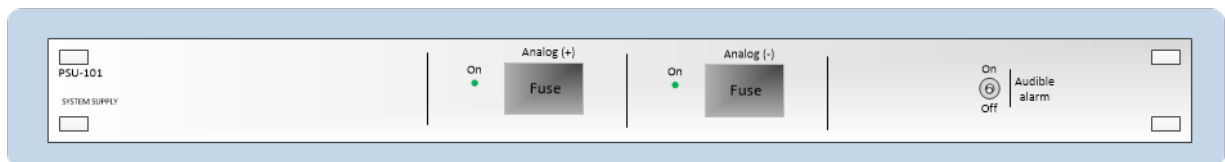

Note: For more information about the power supply for the IMF-3, see the **Interface Module Frames Instruction Manual**.

IMF-3 rear panel

The IMF-3 frame has a rear panel for each interface module. The **layout** of the rear panel is the same for most interface modules. However, the **use** of the rear panel connectors varies according to the type of interface.

To enable easy access to indicators (lights) and controls, locate the interface frame(s) in a convenient location. Interface frames are usually installed near the matrix, but they can be located further away.

The maximum distance between the matrix and the interface frame is **500 feet (150 meters)**.

Eclipse HX matrices have their own power supplies, but do not supply power to connected interface frames. A separate power supply (PSU-101) is required for interface modules mounted in IMF-3 frames. If redundant power supply pairs are used for interface modules, mount them together.

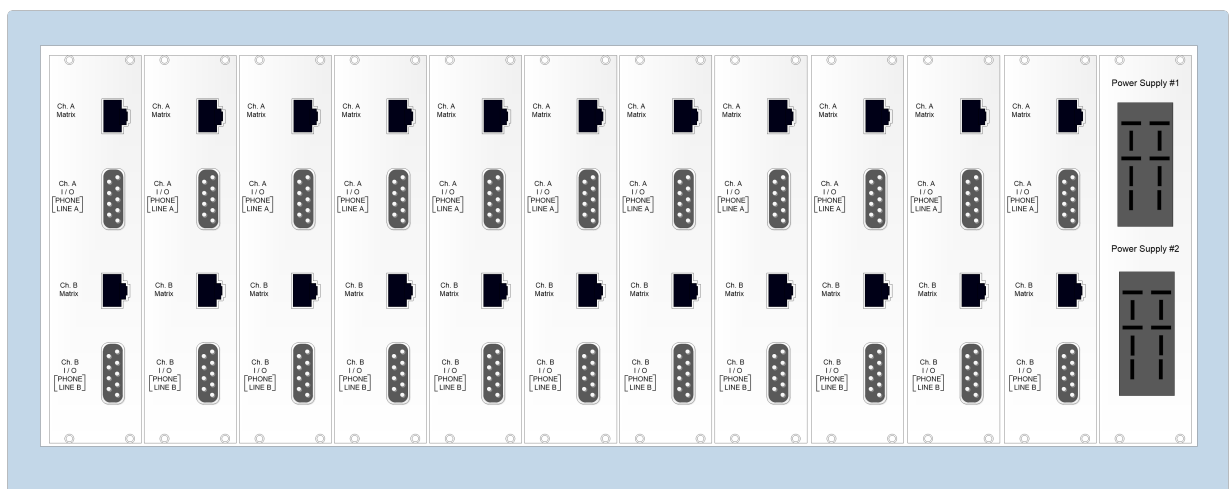

Note For detailed information on power supply requirements, see [Powering System Components](#).

Environmental information:

An extra rack unit (1RU) (1.75 in. or 44.45 mm) must be left above and below each external power supply unit. This enables cooling for larger system loads.

3.2.2 IMF-102 Interface Frame

The IMF-102 is a 1RU interface frame, with slots for two interface modules.

The IMF-102 has an internal power supply and a connector for a redundant power supply.

The rear input/output connector panel has two RJ-45 connectors and DB-9 connectors for each of the two interface modules.

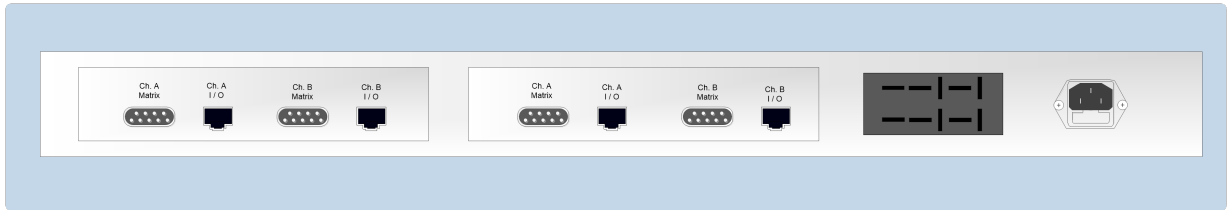

3.3 Locating User Panels

Locate all user panels (V-Series, I-Series and 2X10 Touch Desktop panels) at comfortable heights for operation. To allow for cable connectors, leave at least 2 inches (50.8 mm) of clearance behind the panel chassis. Adjust the brightness of the display to suit your requirements.

Note: To find out more about adjusting the brightness of the display, see your V-Series or I-Series panel manual.

Expansion panels may be mounted as required.

In terms of cabling, the maximum analog cable distance between the matrix and the main user panel is **3000 feet (1000 meters)**.

3.4 Locating the External Computer for EHX

The Eclipse HX configuration software runs on an external computer (PC). The computer is normally connected to the matrix using the LAN1 connector (a standard RJ-45 Ethernet connector).

Ethernet connection allows single or multiple PCs to control, configure, monitor, and diagnose single or multiple matrices from anywhere on the WAN / LAN.

For Eclipse HX-Omega, Eclipse HX-Median and Eclipse HX-PiCo, a ferrite core must be added to the socket end of each Ethernet cable to comply with European EMC standards. A suitable ferrite core is **Würth Elektronik part: 74271132**.

Shielded CAT5 cable is recommended for Electro Magnetic Compliance in EC countries.

Note LAN1 is the default connector on the matrix . The LAN2 connector (which is also a standard RJ-45 Ethernet connector) is **not configured** when it leaves the factory and must be enabled in EHX before it can be used.

You can also connect the external computer to the matrix using a standard PC serial port to DB-9 RS-232 connector. The maximum recommended length of the cable is approximately **10 feet (3.04 meters)**.

Note The Eclipse HX-Pico uses a special null-modem DB9 to 3.5 TRS. The Eclipse HX-Median / HX-Omega / HX-Delta CPU card uses a straight serial cable.

If the EHX computer does not have a serial port, but only provides USB connectors, adapters are available from computer parts suppliers. However, you will be required to install drivers for USB-to-serial port connections.

Because of differences in PC hardware, operating systems and USB-to-serial converters, Clear-Com cannot provide a recommendation for a specific USB-to-serial converter.

4 Powering System Components

This section provides guidance for providing power to the following components of the Eclipse HX system:

- Eclipse HX matrices (Eclipse HX-Omega, Eclipse HX-Median, Eclipse HX-Delta and Eclipse HX-PiCo).
- Interface frame(s) (the IMF-3 and IMF-102), which host interface modules.
- User panels (V-Series, I-Series and 2X10 Touch Desktop panels).

Note: For an overview of the entire installation process, see [Installation Overview](#).

4.1 Powering Matrices

The 6RU Eclipse HX-Omega and Eclipse HX-Median and the 1RU Eclipse HX-PiCo are powered by AC mains lines current. The AC mains current provides power to the internal DC power supplies.

The 3RU Eclipse HX-Delta is powered by two external power supplies.

Each matrix is equipped with two power supplies that can be connected to separate branches of AC mains, providing redundancy for both the power supplies and the power sources.

Power failure event	Fail-safe mechanism
One of the two AC power sources fails / is removed	The matrix continues to operate from the second AC power source.
One of the two internal DC power supplies fails	An alarm failure condition is activated, alerting the system administrator to the fact that the failed DC supply must either be replaced or repaired. The second DC supply continues to power the system.

Note: This information is also applicable to the E-32, the immediate predecessor of the Eclipse HX-PiCo.

4.1.1 Eclipse HX-Omega and Eclipse HX-Median

The Eclipse HX-Omega and HX-Median matrices are supplied with two internal Euro Cassette plug-in power supplies. When both power supplies are connected to AC mains power (using the IEC power connectors on the rear panel), the matrix will continue to operate even if one of the AC power sources fails.

A fully equipped Eclipse HX-Omega or HX-Median matrix requires **100 - 240 VAC** at **50 - 60 Hz** with a maximum dissipation of **300 W**.

4.1.2 Eclipse HX-Delta

The Eclipse HX-Delta's power is provided by two external 12V power supply units (for redundancy). The power supplies have separate connections to the rear of the matrix (see the image of the **Eclipse HX-Delta rear panel**).

Each of the power supplies must be connected to a dedicated branch of AC mains power. The matrix will continue to operate even if one of the power supply units fails.

When the matrix is installed to the rack, connect the power cables from the external power supplies to the power connectors on the rear of the matrix.

The power cables connecting the supplies to the matrix are capable of sustaining a pull test of 10 Newtons. The power cables are secured to the matrix by latching connectors.

When the matrix is connected to the power supplies, connect the power supplies to AC mains power. PSU brackets are available that can be mounted to the 19-inch frame. The PSU brackets can be mounted individually or as a pair.

A fully equipped Eclipse HX-Delta matrix (2 CPU cards, 4 interface cards and 3 interface modules) requires 100 - 240 VAC at 50 - 60 Hz with a maximum dissipation of 175W.

4.1.3 Eclipse HX-PiCo

The Eclipse HX-PiCo matrix has two internal power supply units. One power supply unit can power an entire matrix; the second unit provides a backup in case of equipment failure.

In addition, the two supplies have separate IEC connectors to AC mains power, and are designed for completely automatic and transparent changeover between supplies in the event of an outage on one of the AC mains circuits.

The power supplies are universal, operating over a voltage range of **100 - 240 VAC** at **50 - 60 Hz**.

An HX-PiCo requires **100 - 240 VAC** at **50 - 60 Hz** with a maximum dissipation of **40 W**.

***Note** The same information is applicable to the E-32, the immediate predecessor of the : Eclipse HX-PiCo.*

4.2 Powering User Panels

4.2.1 V-Series Panels

V-Series panels, including expansion panels, have an **external DC** power supply.

The power supply is universal, operating over a voltage range of **100 - 240 VAC** at **50 - 60 Hz**. The maximum dissipation is **50W**.

4.2.2 2X10 Touch Desktop panel

The 2X10 Touch Desktop panel has a 2.5mm Power jack connector with screwlock retention to accept the required input power of 12VDC, 2A.

An AC/DC Desk Top Power Adapter is supplied with the unit. The power adapter has the following specification:

- Input connector : IEC-320 C14 male receptacle
- Input AC Voltage range : 100-240VAC
- Input Frequency range : 50-60Hz
- Input current : 1.2A
- Output DC Voltage : 12VDC
- Output rated current : 3.5A
- Output connection : 2.5mm DC power plug (with 1.5meters lead)

4.2.3 I-Series Panels

I-Series panels have an **internal** power supply, with a removable AC power cable.

The power supply is universal, operating over a voltage range of **90 - 245 VAC** and **50 - 60 Hz**. The maximum dissipation is **40W**.

4.3 Powering Interface Frames

4.3.1 IMF-3

The IMF-3 interface frame requires an external PSU-101 power supply (see the **PSU-101 power supply for IMF-3** image below).

Usually, **one PSU-101** power supply unit is required for approximately every **two** IMF-3 frames. This requirement may differ where:

- **The IMF-3 is hosting a large number of CCI-22 partyline interface modules**, which require no DC power from the IMF-3 frame (the modules are powered from the partyline connection).

However, even if the IMF-3 only contains CCI-22 interface modules, a PSU-101 power supply is still required to power the circuitry on the rear panel of the IMF-3.

- **The IMF-3 is hosting multiple TEL-14 telephone interface modules**. An IMF-3 interface frame can only power eight TEL-14 interfaces on one PSU-101 power supply. If more TEL-14 interface modules are required, they must be installed in a second IMF-3

frame with a second power supply.

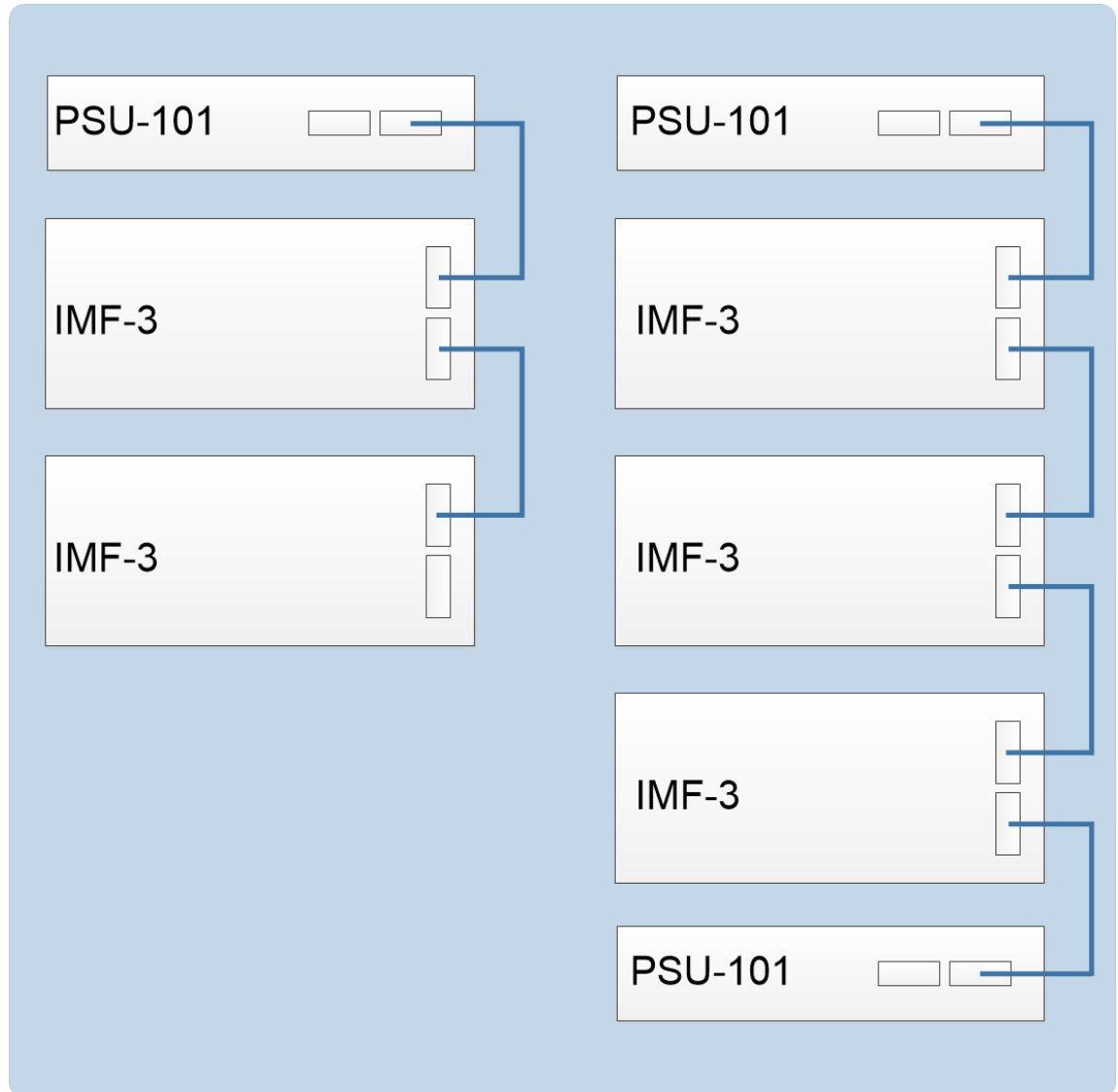

Installing **two** PSU-101 power supplies for each IMF-3 provides redundancy, because either of the two PSU-101 power supplies can power a complete system.

If one fails, it can be removed without interruption of the entire system. Rear panel connectors provide easy parallel connection to the IMF-3 interface frame.

A PSU-101 requires **90 - 260 VAC** at **45 - 65 Hz** with a maximum dissipation of **80W**.

PSU-101 alarm

An audible alarm is included in the **PSU-101**, and an additional set of alarm-relay contacts are provided on the supply.

Clear-Com recommends that these contacts be connected to the external alarm input of the matrices. If any of the power supplies in the PSU-101 fails, a system alarm is activated. LEDs on the front of the PSU-101s indicate the failure.

Note: For more information about the IMF-3, see the **IMF-3 Manual**.

4.3.2 IMF-102

The IMF-102 has an internal power supply and a rear panel connector for connecting redundant power. The power supply is universal, operating over a voltage range of **90 - 250 VAC**. The maximum dissipation is **20W**.

Note An additional power supply can be added for redundancy by connecting a PSU-101 power supply to the power connector on the rear panel.

For more information, see the **IMF-102 Interface Module Instruction Manual**.

4.3.3 Current Capacities and Consumption

The current capacities of the power supplies are as follows:

- **+9 V analog** **3.0 A**
- **-9 V analog** **3.0 A**

The following chart provides the current drain of the +/- analog power supplies for interface modules and the IMF-3 interface frame.

Note Some devices, such as interface modules, have a varying current depending on the operation of features. In Eclipse HX devices where it is possible to activate all operating features of all components used, use the maximum current column for planning.

Component	Average current	Maximum
IMF-3	0.20 A	0.20 A
CCI-22	0.00 A	0.00 A
FOR-22	0.07 A	0.15 A
TEL-14	0.28 A	0.37 A
RLY-6	0.10 A	0.15 A
GPI-6	0.02 A	0.02 A
AES-6	0.16 A	0.16 A

5 Wiring System Components

This section describes how to connect an Eclipse HX matrix (Eclipse HX-Omega, Eclipse HX-Median, Eclipse HX-Delta or Eclipse HX-PiCo) to other system components, including:

- The EHX PC.
- User panels (V-Series, I-Series and 2X10 Touch Desktop panel).
- Interface frames and interface modules.
- External alarms.
- Four-wire audio devices.
- Analog partyline systems (including Clear-Com Encore).

It also includes guidance on using GPIs / GPOs to trigger actions, and procedures for enabling E & M signaling.

Most user panels and interfaces connect to a matrix using CAT5 single 4-pair shielded RJ-45 terminated cables.

Note: For an overview of the entire installation process, see [Installation Overview](#).

For more information about component placement, specifications of individual products, and internal adjustments, see the specific documentation for that product. To configure user panels and interface modules, see your *EHX documentation, including EHX Help*.

5.1 Using RJ-45 Connectors

The following section provides guidance on the use of RJ-45 connectors for connecting an Eclipse HX matrix) to other Eclipse HX system components.

All Eclipse HX devices have built-in RJ-45 connectors. Direct 4-pair cable with RJ-45 connectors on either end can connect an Eclipse matrix port to an individual panel. Shielded CAT5 cables are available with RJ-45 terminations already installed. Bulk RJ-45 connectors can be bought and installed on custom length cables.

5.1.1 Cabling Standards

The term **category 5 (CAT5)** refers to a communications cable standard that calls out transmission characteristics of twisted-pair cables for data communication use. For each increasing **category (CAT)** number the guaranteed bandwidth for data communication purposes increases.

For the 4-pair wiring scheme between the matrix panels, Eclipse HX uses the **T568B** wiring standard for data cables, and solid or stranded wire in either **#24** or **#26 AWG**.

There are at least five different wiring standards that use the RJ-45 connector. Although they look identical, many pre-made cables and utility items, like couplers, will not work properly with your Eclipse HX system. It is essential to know what wiring standard is used in any accessories.

Clear-Com recommends:

- The use of shielded CAT5 twisted cable with RJ-45 connectors on either end. However, there are various methods available to deliver these cables from one place to another.
- The use of shielded cables throughout the installation for EMC conformance. Unshielded cables can be used but in this case Clear-Com does **not** guarantee the crosstalk and noise figures.

Long runs with flat cable are **not** recommended. The data and audio pairs are **not** twisted which means that the crosstalk within the cable is high.

Cabling standard	Description
T568B	<p>A mature, well supported standard. Advantages include:</p> <ul style="list-style-type: none"> • Fast easy termination of cables. • The availability of a vast array of wiring adapters and patching systems, permitting greater versatility when wiring Eclipse HX devices. • RJ-45 connectors can be connected to hardware quickly and easily.
T568A	<p>T568A cables differ from T568B cables only in terms of the color of the insulation used on pairs 2 and 3.</p> <p>If you are not removing the ends from a pre-made cable, then this difference should not cause any issues.</p> <p>However, if the ends are removed from a pre-made cable (to shorten the cable or to punch the cable onto blocks), you should take account of the fact that the insulation colors for pairs 2 and 3 may differ.</p>

Note: Test all cables thoroughly before connecting them.

5.1.2 Recommended Cables, Connectors and Wiring Tools

Ensure that the type of RJ-45 connector matches the wire type. Connectors are available for both stranded and solid wire. Clear-Com intercom panels do not require keyed connectors. See the following table for connector vendor and port numbers.

The following products are recommended as possible sources for cables, connectors and tools:

Product type	Recommended product(s)
Crimper	Siemon PT908 or AMP 2-231652-1 with 853400-1 dies
Stripper	Siemon CPT
Tester	Siemon STM-8
Connector RJ-45 Shielded 26-22 AWG Stranded or Solid RJ-45	Siemon PS-8-8
Cinch	CINCH FA-25PS/1-LF 25W D-type in-line 1000pF filter (UK supplier: Farnell 111-4108)
Ferrite core	Würth Elektronik part: 74271132

5.1.3 Installing RJ-45 Connectors

The following procedures are designed to help you install RJ-45 connectors correctly. Clear-Com recommends that the work is tested with a cable checker, validator or certifier. When you are installing RJ-45 connectors, wires can slip out of the correct order as the prepared cable end is inserted into the connector.

The shorter, **general** procedure for avoiding this issue is as follows:

1. Strip enough jacket off the cable to be able to grasp the wires and pull the jacket back.
2. Untwist the wires and pull them into the correct order and let the jacket slip back to hold them in place.
3. If this is done correctly, the wires will stay in the correct order. Trim exposed wires to about 9/16 in. (14.28mm) and install into the connector.

The **detailed** procedure is as follows. To facilitate the installation of RJ-45 connectors:

1. Strip off enough of the outside vinyl jacket to be able to grip the wires inside easily (**2 in. or 50.8 mm**).

While holding the four twisted pairs in one hand, slide back the vinyl jacket and clamp it between your thumb and forefinger. Keep the jacket clamped in this retracted position until the fourth step.

2. Pull the twisted pairs to the one side and untwist them back to the edge of the vinyl jacket. Smooth the kinks out slightly by pulling the conductors through your fingers.

3. In the correct color sequence, pull one wire at a time, straight out, clamping it in place between your thumb and forefinger.

If a wire must cross the others, ensure that this occurs inside the jacket. Ensure that your color sequence matches the other side and it does not reverse.

Note: *If you are rebutting a cable, verify the color code. The twisted pairs must be positioned correctly.*

4. While holding the wires in the correct order, release your clamped thumb and forefinger enough to allow the retracted jacket to slip back.

You must still maintain enough pressure on your thumb and forefinger to hold the jacket and wires flat, but the individual wires should stay in the correct order without holding them with your other hand.

5. Cut the exposed wires to the correct length and slip them into the RJ-45 connector as you release your clamped thumb and forefinger.

6. Crimp and test the cable.

Note: *Care must be exercised that the shield is not left pulled back inside the wire jacket. We also recommend that the drain wire is soldered to the side of a shielded style connector. Our tests show that a drain wire that is only crimped and not soldered will make an intermittent connection at best.*

5.2 Connecting the Matrix to a PC Running EHX

The Eclipse configuration software (EHX) application is run on a PC.

5.2.1 Ethernet Connection to the PC

The computer is normally connected to the matrix using:

- The **LAN1** connector (a **standard RJ-45 Ethernet connector**) on the rear of an Eclipse HX-Omega, Eclipse HX-Median or Eclipse HX-Delta matrix.

Note: *LAN1 is the default connector on the Eclipse HX-Omega, Eclipse HX-Median and Eclipse HX-Delta matrix. The LAN2 connector (which is also a standard RJ-45 Ethernet connector) is **not configured** when it leaves the factory and must be enabled in EHX before it can be used.*

- The **LAN** connector (a standard RJ-45 Ethernet connector) on the rear of the Eclipse HX-PiCo.

Ethernet connection allows single or multiple PCs to control, configure, monitor, and diagnose single or multiple matrices from anywhere on the WAN / LAN (see also the **Connecting the matrix to an Ethernet network** section).

For Eclipse HX-Omega, Eclipse HX-Median and Eclipse HX-PiCo, a ferrite core must be added to the socket end of each Ethernet cable to comply with European EMC standards. A suitable ferrite core is **Würth Elektronik part 74271132**.

Shielded CAT5 cable is recommended for Electro Magnetic Compliance in EC countries.

5.2.2 Serial Connection to the PC

You can also create a serial connection between the matrix and the EHX PC, using. :

- The **DB-9F** connector labeled **RS-232** on the rear of an Eclipse HX-Omega, Eclipse HX-Median or **Eclipse HX-Delta** matrix.
- The **3.5mm jack socket** labeled **RS-232** on the front of an **Eclipse HX-PiCo**.

Note: *Shielded CAT5 cable should be used, where possible.*

Eclipse HX-Median, Eclipse HX-Omega and Eclipse HX-Delta

To connect the EHX PC to the matrix, run cable from the matrix's R-232 DB-9M serial connector to the 9-pin serial port of the PC (see **Figure 6: PC serial DB-9F to matrix R-232 DB-9M connector**). The maximum recommended length of the cable is approximately 10 feet (3 meters).

Note: *If the EHX computer does not have a serial port, and only offers USB, adaptors are generally available from computer parts suppliers.*

PC serial DB-9F
connector

System frame R-232
DB-9M connector

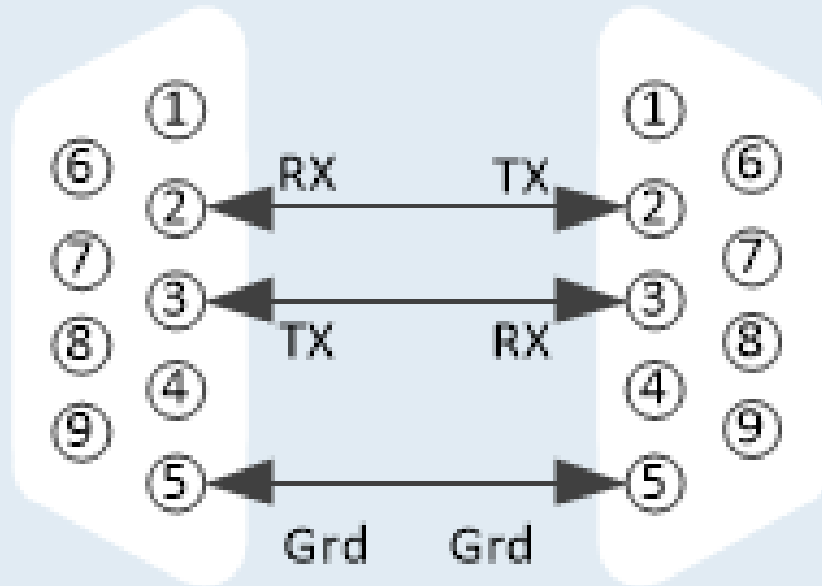

Eclipse HX-PiCo

A **DB-9F** connector is used at the PC, when wiring for an Eclipse HX-PiCo serial connection. The **3.5mm jack socket** is labeled **RS-232** on the front of an Eclipse HX-PiCo. Ensure that:

- The data connections of **Pin 2 to jack plug tip** and **Pin 3 to jack plug ring** are followed.
- **Pin 5 (DB-9F)** goes through to the **jack plug screen**.

The cable will then be ready to use.

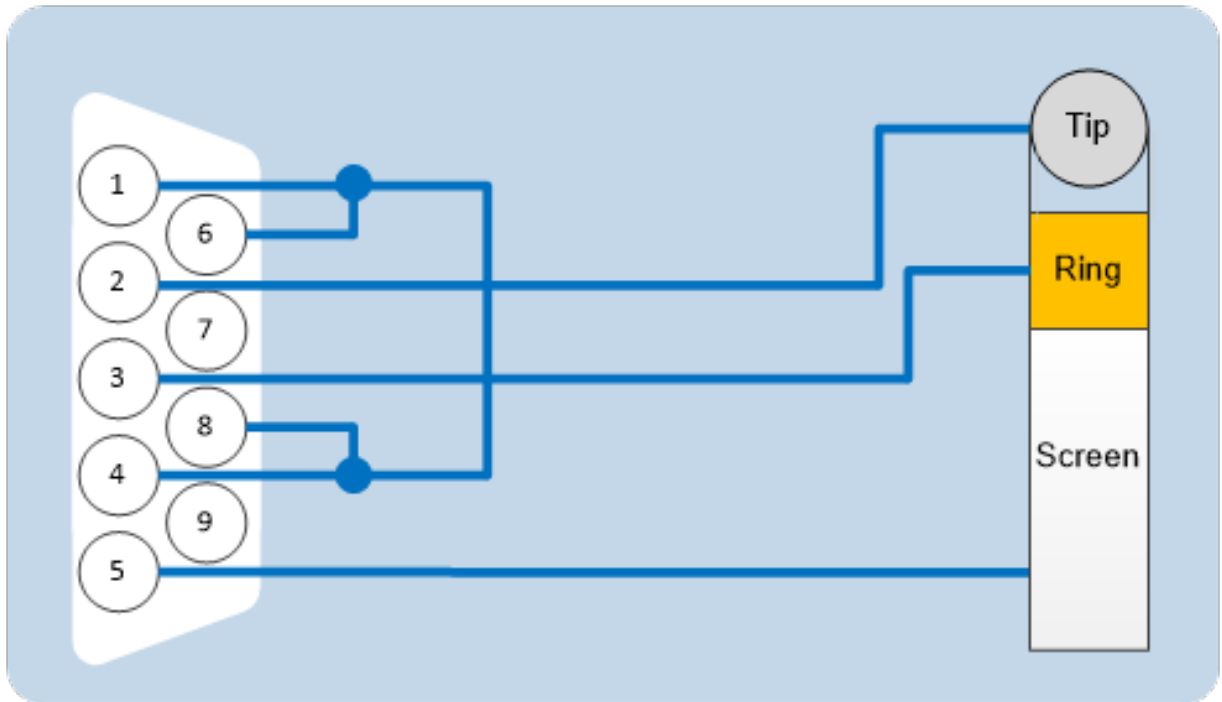

PC Connection (DB-9F)	Eclipse HX-PiCo (3.5mm jack)
Pin 1	Links to Pins 4,6,8 on PC side
Pin 2	Tip
Pin 3	Ring
Pin 4	Links to 1, 6, 8 on PC side
Pin 5	Screen
Pin 6	Links to Pins 1, 4, 8 on PC side
Pin 7	N/C
Pin 8	Links to 1, 4, 6 on PC side
Pin 9	N/C

5.3 Connecting the Matrix to an Ethernet Network

To connect a matrix to an Ethernet network (WAN / LAN), use:

- The **LAN1** connector (a **standard RJ-45 Ethernet connector**) on the rear of an Eclipse HX-Omega, Eclipse HX-Median or Eclipse HX-Delta matrix.

Note: **LAN1** is the default connector on the Eclipse HX-Omega / Eclipse HX-Median / Eclipse HX-Delta matrix . The **LAN2** connector (which is also a standard RJ-45 Ethernet connector) is **not configured** when it leaves the factory and must be enabled in EHX before it can be used.

- The **LAN** connector (a standard RJ-45 Ethernet connector) on the rear of the Eclipse HX-PiCo.

For Eclipse HX-Omega, Eclipse HX-Median and Eclipse HX-PiCo, a ferrite core must be added to the socket end of each Ethernet cable to comply with European EMC standards. A suitable ferrite core is **Würth Elektronik part 74271132**.

Shielded CAT5 cable is recommended for Electro Magnetic Compliance in EC countries.

See also the **Ethernet connection to the PC** section.

Pin	Function
Pin 1	Transmit data +
Pin 2	Transmit data -
Pin 3	Receive data +
Pin 4	N / C
Pin 5	N / C
Pin 6	Receive data -
Pin 7	N / C
Pin 8	N / C

Note: Shielded CAT5 cable should be used, where possible.

5.4 Connecting the Matrix to a PC Running Dynam-EC

Dynam-EC is the is a multi-user, multi-matrix PC based software package which provides fast, intuitive audio routing control for Eclipse HX systems.

Note: For more information, see the product description on the Clear-Com website.

5.4.1 LMC-64 Interface Card

Access to the audio level metering functionality of Dynam-EC is usually achieved using the **LMC-64 interface card**.

For more information about the LMC-64 interface card (which you can fit to either an Eclipse HX-Omega, Eclipse HX-Median or Eclipse HX-Delta matrix), see the:

- *LMC-64 Manual*
- *Eclipse HX-Omega User Guide*
- *Eclipse HX-Median User Guide*
- *Eclipse HX-Delta User Guide*

5.5 Connecting the Matrix to User Panels

The Eclipse HX system uses a 4-pair (analog) wiring scheme between the matrix and user panels (V-Series, I-Series and 2X10 Touch Desktop panels). All supported panels have built-in RJ-45 connectors.

5.5.1 4-Pair Analog Wiring

4-pair analog wiring is performed with shielded CAT5 RJ-45 cable:

Pair	Description
Pair 1	Transmits analog audio from the matrix to the panel.
Pair 2	Transmits digital data from the panel back to the matrix.
Pair 3	Transmits audio from the panel to the matrix.
Pair 4	Transmits digital data from the matrix back to the panel.

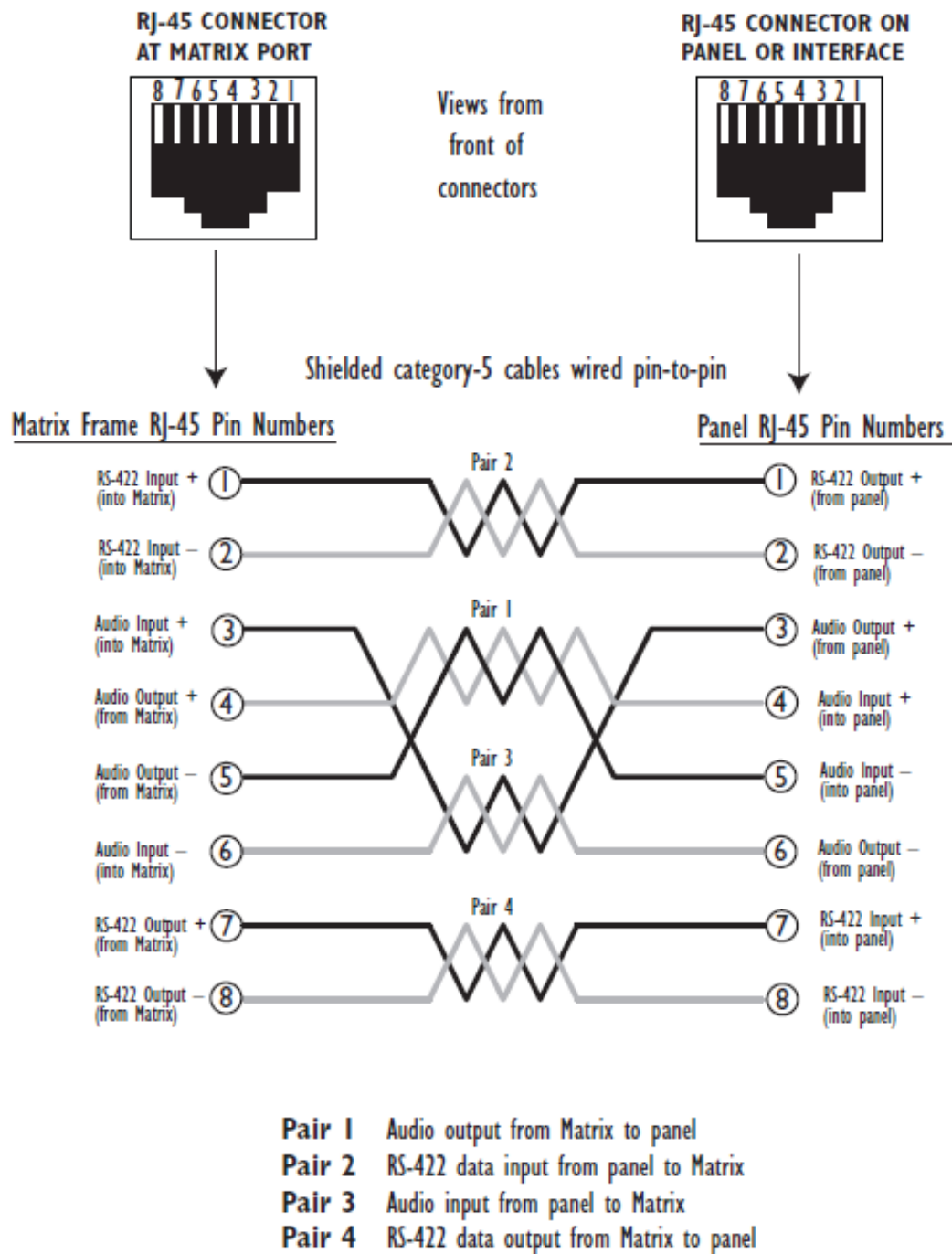

5.6 General Purpose Outputs (GPOs)

A general purpose output (GPO) or relay is a switch that is controlled remotely. The relay is programmed in EHX to close a contact whenever a user panel’s key is pressed. When the

contact is closed, it completes an electronic circuit's signal path so that a remote device (such as a light) is powered.

A GPO can be programmed to mute a speaker, to turn on an applause light, open a door lock, or perform a variety of other functions.

The **male 25-pin D-type socket** labeled **GP OUT** on the rear of the matrix connects to eight general-purpose outputs (GPOs). The general purpose outputs are single-pole double-throw relays with contact ratings of **30 VDC (volts direct current) at 1 ampere**.

Shielded cable should be used to connect GPOs.

If the **GP-OUT** port is used on **either** an HX-Omega matrix fitted with **XP** power supplies (part 740101Z) **or** an Eclipse HX-Median matrix fitted with **HITRON** power supplies (740134Z) the following filter must be fitted between the **PROC-RCC** socket and the cable:

CINCH FA-25PS/1-LF 25W D-type in-line 1000pF filter

(UK supplier: Farnell 111-4108)

This is an EMC conformance requirement only.

If the Eclipse HX-Omega / Eclipse HX-Median matrix is equipped with Power-One power supplies (720379Z), this filter should not be fitted. If this filter is already fitted to the Eclipse HX-Omega or Eclipse HX-Median and the power supplies are changed to Power-One units, the filter must be removed before the matrix is powered up.

Each general-purpose output (GPO) has a relay inside the Eclipse HX-Omega, Eclipse HX-Median or Eclipse HX-Delta matrix. When a general-purpose output is:

- **Inactive**, the associated **common** pin on the **GP OUT** connector is shorted to the relevant normally closed pin.
- **Active**, the short between the **common** pin is broken and a new connection is made between the **common** pin and the **normally open** pin.

DB-25M Connector		
Pin	Description	Relay
Pin 1	Common	RELAY1
Pin 2	Normally closed	
Pin 3	Normally open	
Pin 4	Common	RELAY2
Pin 5	Normally closed	
Pin 6	Normally open	

DB-25M Connector		
Pin 7	Common	RELAY3
Pin 8	Normally closed	
Pin 9	Normally open	
Pin 10	Common	RELAY4
Pin 11	Normally closed	
Pin 12	Normally open	
Pin 13	Digital ground	-
Pin 14	Common	RELAY5
Pin 15	Normally closed	
Pin 16	Normally open	
Pin 17	Common	RELAY6
Pin 18	Normally closed	
Pin 19	Normally open	
Pin 20	Common	RELAY7
Pin 21	Normally closed	
Pin 22	Normally open	
Pin 23	Common	RELAY8
Pin 24	Normally closed	
Pin 25	Normally open	

Note: See also the Pin configuration of the GPO connector (DB-25M) below.

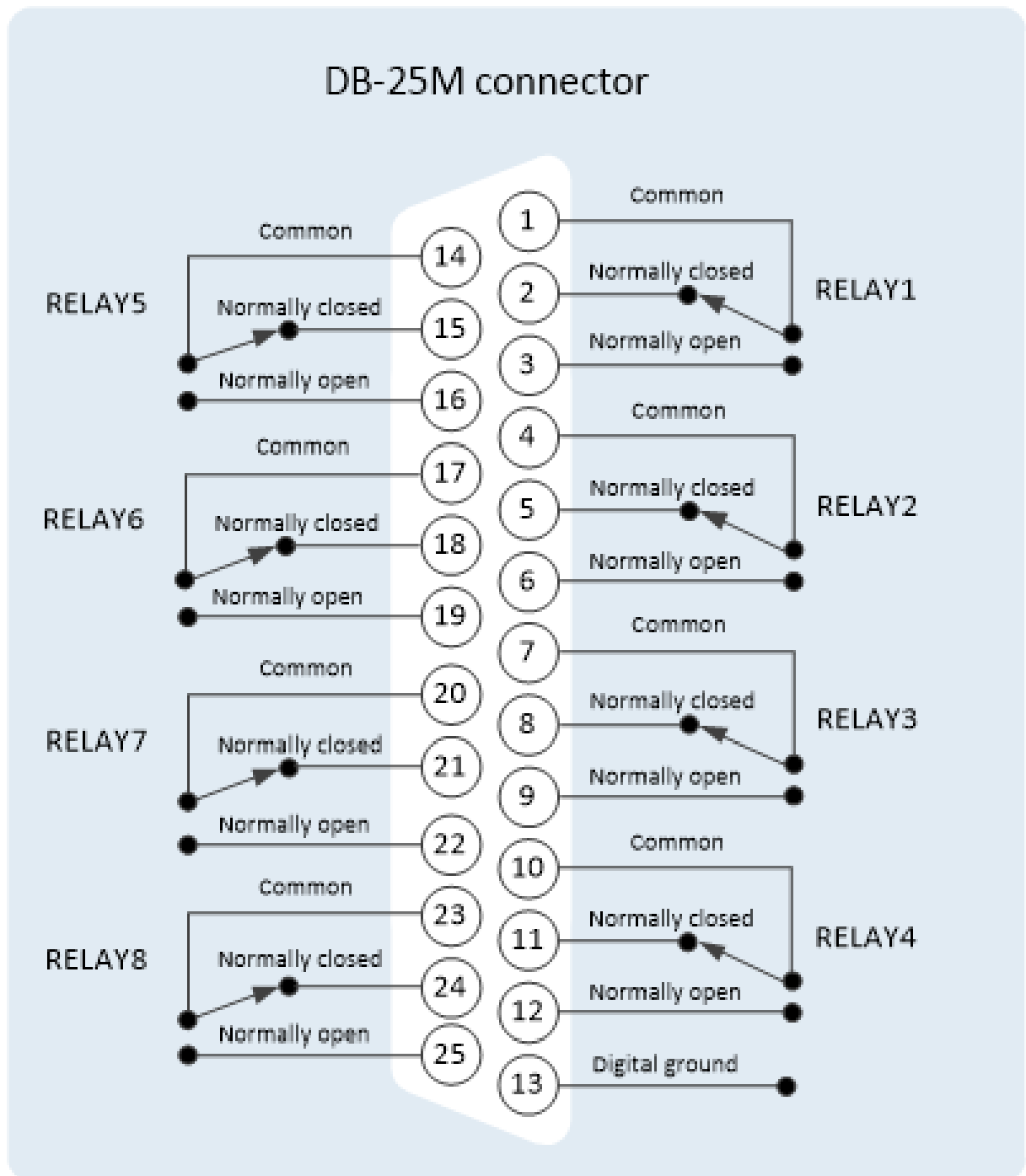

Note The general purpose outputs are single-pole double-throw relays with contact ratings of : 30 VDC (volts direct current) at 1 ampere.

5.7 General Purpose Inputs (GPIs)

You can connect an external logic device (such as an external foot switch, a panel-mounted switch, or the logic output of some other device) to the connector labeled **GP IN** on the rear of the Eclipse HX matrix.

When the external logic device is activated, it sends a control signal into the matrix to perform one of several preset functions, such as turning an intercom panel's microphone on or off, muting a microphone's output, or turning a panel's speaker off. The function to perform and the panel upon which it is performed is configured using the Eclipse configuration software (EHX).

The DB-25 connector labeled **GP IN** on the rear of the Eclipse matrix connects to eight local general-purpose inputs. The GPIs are opto-isolated. Shielded cable should be used to connect GPIs.

DB-25F Connector	
Pin	Description
Pin 1	Logic input 1
Pin 2	Logic input 2
Pin 3	Logic input 3
Pin 4	Logic input 4
Pin 5	N / A
Pin 6	N / A
Pin 7	N / A
Pin 8	N / A
Pin 9	Ground
Pin 10	Ground
Pin 11	Ground
Pin 12	Ground
Pin 13	Ground
Pin 14	Logic input 5
Pin 15	Logic input 6
Pin 16	Logic input 7
Pin 17	Logic input 8
Pin 18	N / A
Pin 19	N / A

DB-25F Connector

Pin 20	N / A
Pin 21	N / A
Pin 22	V IN +
Pin 23	V IN +
Pin 24	V IN -
Pin 25	V IN -

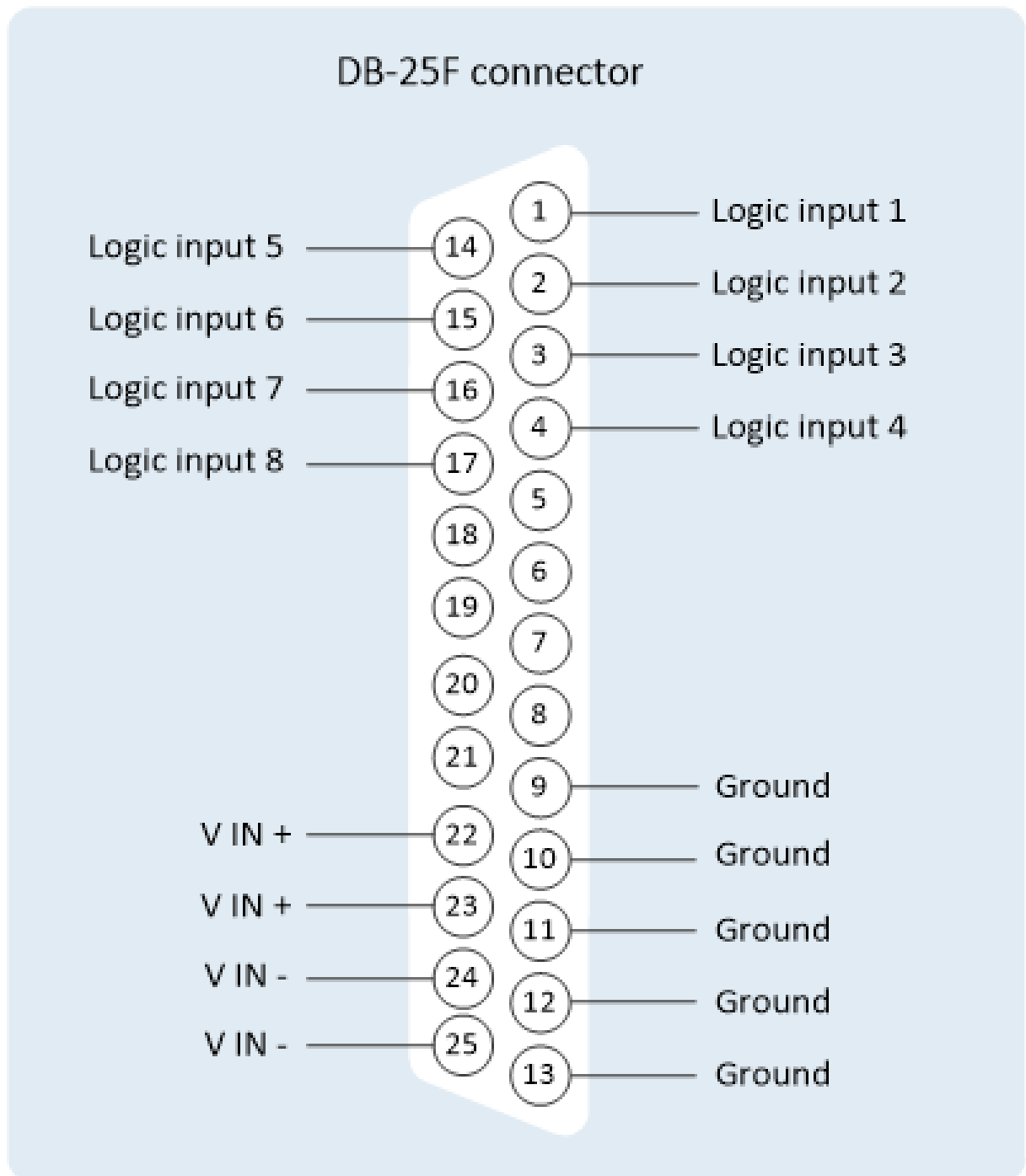

5.7.1 Modes for General Purpose Inputs (GPIs)

General-purpose inputs (GPIs) operate in either of two modes:

- **Opto-isolated mode**, which requires the externally connected equipment to provide the current to power the general-purpose input.

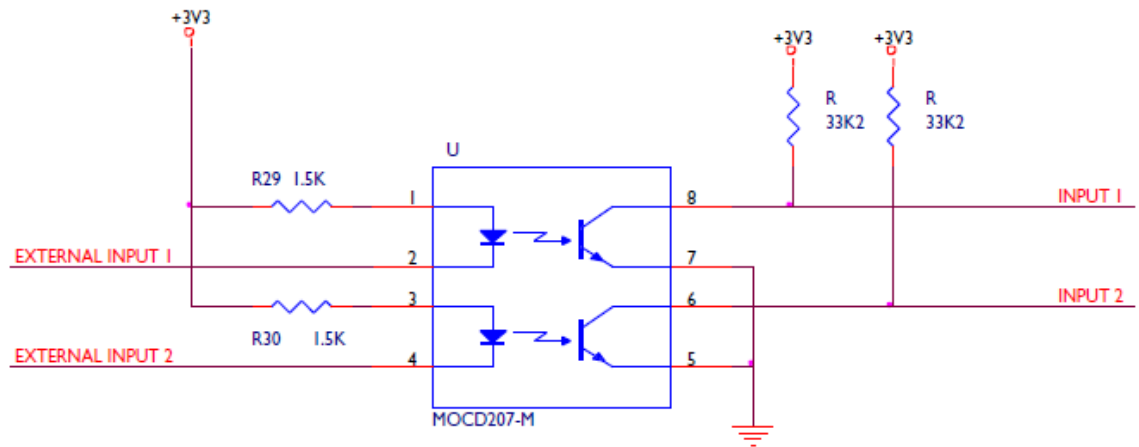

To cause an input to detect an active signal, current must flow from the relevant input pin.

The external device should draw no current to cause an inactive input and at least **5 mA** to cause an active input. The opto-isolator drive line contains a **1.5 kOhm** resistor to limit the current through the opto-isolator. Therefore the input pins can be connected directly to a ground pin to cause an active input.

The voltage level at the external input pin should **not** be allowed to go below ground or above **+6** with respect to ground.

Note The **Logic 1** input (external input 1) must be shorted to ground to render the **Logic 1** : signal active.

5.8 E & M Signalling with an E-QUE E1 / T1 Interface Card

When you enable E & M signaling on an E1 / T1 direct E-QUE card, you associate a GPI and a GPO in EHX with each configured port.

You can use the:

- GPI (General Purpose Input) to trigger an action / control on an **incoming signalization**.
- GPO (General Purpose Output) to trigger an **outgoing signalization** from a control.

5.8.1 Example: Ship-to-Shore Satellite System

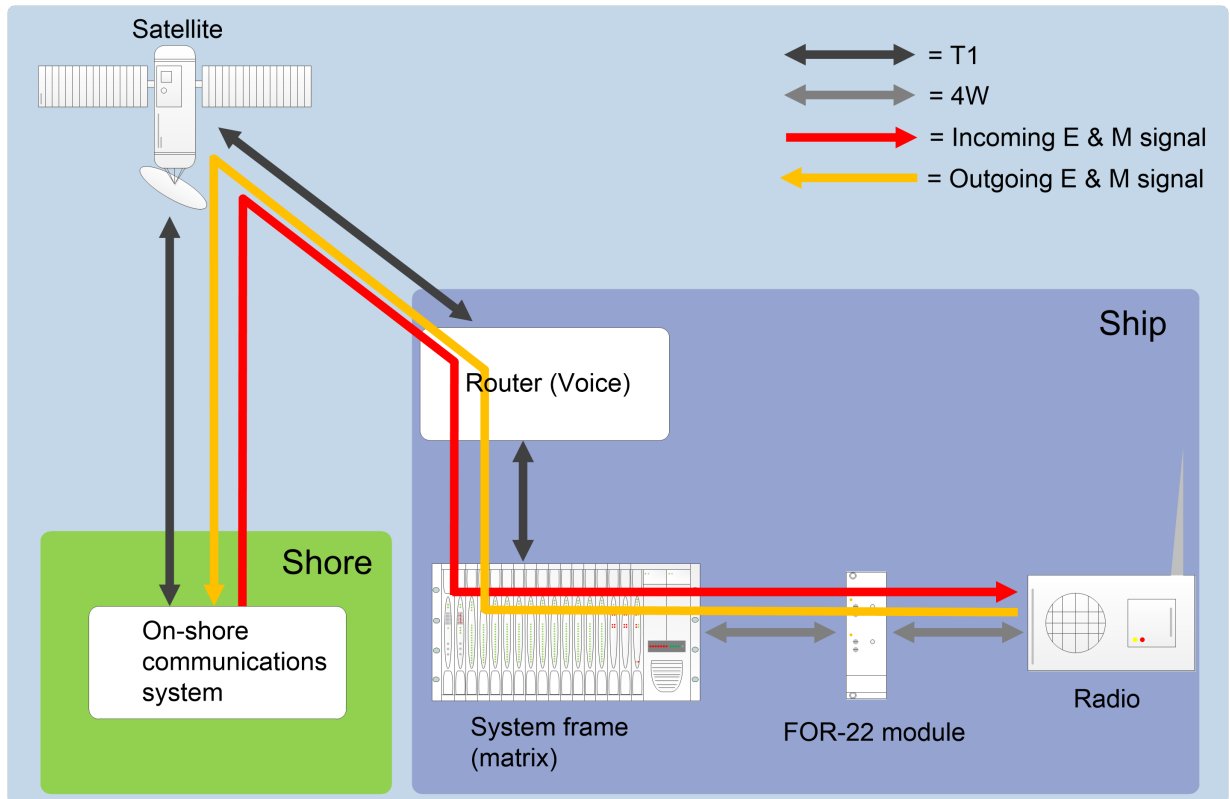

In the image above, E & M signaling is carried with audio channels on the direct T1 connection and then split into logic functions in the matrix:

1. The **direct E1 / T1 connection** carries audio and E & M signaling (the **incoming E & M signal**) from the on-shore communications system.
2. The E & M signal is received by the E-QUE card in the matrix, and treated as a **GPI** by the matrix.
3. The **GPI** generates the audio routes (where applicable) and indication outputs required by the **FOR-22 interface module** to generate relay closure for **radio PTT (Push-to-Transmit)**.
4. The **FOR-22** transmits incoming audio from the ship radio to the matrix.
5. The incoming audio is VOX detected in the matrix's MVX-A16 analog card.

The MVX-A16 card is configured in EHX to generate the required audio routes (where applicable) and drive E signaling, as represented by a **GPO** on the appropriate T1 channel of the E-QUE card.

6. The **direct E1 / T1 connection** carries audio and E & M signaling (the **outgoing E & M signal**) to the on-shore communications system.

Tip: For more information about direct E-QUE E1 / T1 connections, see [E1 / T1 Linking](#).

5.8.2 Enabling E & M Signaling on the E-QUE Card

To enable E & M signaling on an E1 / T1 direct E-QUE card:

1. In EHX, select the appropriate matrix. Go to **Hardware > Cards and Ports**.
2. From the **Card Slot** drop-down menu, select an available card slot.
3. From the **Card Type** drop-down menu, select either of the following card types (in accordance with your requirements):
 - E-QUE (T1 Direct)
 - E-QUE (E1 Direct)
4. The ports are displayed for the selected card type. Configure as many ports as you require as **T1 / E1 Direct**.

Note: A T1 direct E-QUE card has 48 ports. An E1 direct E-QUE card has 60 ports.

5. Click **Card Properties** (to the right of the ports screen).
6. In **Card Properties > Clock Recovery**, ensure that **Line recovery** is selected.

*Note: In Card Properties > Codec, select the appropriate **Top Half** and **Bottom Half** Codec.*

7. In Card Properties > Codec, select the appropriate Top Half and Bottom Half Codec.

*Note: **Top Half** (T1 direct = ports 1 – 24 / E1 direct = ports 1 – 30) and **Bottom Half** (T1 direct = ports 25 – 48 / E1 direct = ports 31– 60) correspond to the two physical T1 / E1 connections with the E-QUE card*

Recommendation: For **T1 direct E-QUE cards**, Clear-Com recommends that you select the **G711 μ -law** codec for optimum audio quality.

The screenshot shows a configuration window titled "Codec". It has two sections: "Top Half:" and "Bottom Half:". Each section contains three radio button options: "G722", "G711 A-law", and "G711 u-law". In both sections, the "G711 u-law" option is selected, indicated by a blue dot in the center of the radio button.

8. In **Card Properties > E & M Signaling**, select **Enable E & M Signaling** [].

Click **OK**. Top Half (T1 direct = ports 1 – 24 / E1 direct = ports 1 – 30) and **Bottom Half** (T1 direct = ports 25 – 48 / E1 direct = ports 31– 60) correspond to the two physical T1 / E1 connections with the E-QUE card

9. To view the ports associated with GPIs, open the **Matrix and Modular GPIs** screen by clicking the tab at the bottom of the ports screen.

5.8.3 Using the GPIs / GPOs to Trigger Actions

After enabling E & M signaling on the E1 / T1 E-QUE cards, you can use the GPIs / GPOs associated with the configured ports to trigger actions.

For example, in the earlier example: **Ship-to-shore satellite system**:

1. The E & M signal from the shore-based communications system is forwarded by the matrix to the FOR-22 interface module. The FOR-22 module then generates relay closure for **radio PTT (Push-to-Transmit)**.
2. An E & M signal is returned to the matrix to indicate that audio from the radio is being received.

To send E & M signals from the matrix to a ship's radio, and to receive E & M signals in the matrix from the activated radio:

1. In EHX, select the appropriate matrix. Go to **Configuration > Routes**.
2. In **Configuration > Routes**, add two new routes:
 - a. Create a route from the first configured port on the E & M enabled E1 / T1 direct E-QUE card to the first available port on the FOR-22 interface module.
Label the route (for the purposes of this example) **Radio Out**.
 - b. Create a route from the first available port on the FOR-22 interface module to the first configured port on the E & M enabled E1 / T1 direct E-QUE card.
Label the route (for the purposes of this example) **Radio In**.
3. In **Configuration > Controls**, add two new controls:
 - a. Label the first control **PTT1**.
 - b. Add the **Radio Out** route to **PTT1**.
 - c. Add the FOR-22 interface module relay / GPO (a relay associated with the FOR-22 port in the Radio Out route) to **PTT1**.

Note: This relay is used to trigger PTT at the ship's radio.

- d. Label the second control **REC1**.
- e. Add the **Radio In** route to **REC1**.
- f. Add the **E & M relay / GPO** (the relay associated with the first configured port on the E1 / T1 direct E-QUE card) to **REC1**.

***Note:** This relay receives the E & M signal from the ship's radio into the matrix.*

4. In **Configuration > Cards and Ports > Matrix and Module GPIs:**

- a. Select the appropriate **E & M enabled GPI** (the GPI associated with the first configured port on the E1 / T1 direct E-QUE card).
- b. In **Advanced Settings**, enable / select the trigger for the **PTT1** control.

***Note:** When the E & M signal is received from the shore-based communications system at the E1 / T1 direct E-QUE card, the E & M signal is sent to the FOR-22 / radio.*

5. In **Configuration > System Ports:**

- a. Select the port for the FOR-22 interface module.
- b. In **Advanced Settings > VOX action**, select the **REC1** control from the drop-down menu.
- c. In **Advanced Settings > VOX action > Voice Op. Switch**, adjust the *Audio Off Delay and Audio Detect Threshold* as required.

***Note:** When VOX is detected, the E & M signal for the FOR-22 / radio is sent via the E1 / T1 direct E-QUE card to the shore-based communications system.*

5.9 Connecting the Matrix to an External Alarm

You can connect the Eclipse HX-Omega / Eclipse HX-Median / Eclipse HX-Delta matrix to an external alarm device using the **Alarm I/O DB-9F connector**.

Pins are also available for connecting an external alarm source to the matrices internal Alarm System.

***Note** For details on the functions that are monitored by the Alarm System, see the **Eclipse HX-Omega, Eclipse HX-Median or Eclipse HX-Delta User Guides**.*

When an external alarm is connected to the matrix, a system failure will activate the relay contacts connected to **pins 4, 5, and 9** of the **Alarm I/O DB-9F connector**.

Note The relay contacts connected to **pins 4, 5 and 9** are 'dry', and are rated at **1 A at 24 VDC**. They are not recommended for AC mains line current.

Pins are provided for adding an additional alarm source to the matrix's alarm system. **Pin 6** is an alarm input to the matrix. The pin is connected to the input of a **3.3V** logic device. A logic high on this input will cause an alarm condition in the matrix.

Pin 1 is a voltage source out of the matrix. It is connected through a 10k ohm pull-up resistor to the +5 volt supply rail inside the matrix. A contact closure placed across **pins 1 and 6** will also cause an alarm condition.

5.9.1 Connecting to the Alarm Outputs of the PSU-101 Power Supply

The alarm outputs of the PSU-101 could be wired directly to the pins of the **Alarm I/O DB-9F connector** described above, permitting the CPU card to report PSU failures also. Shielded cable should be used.

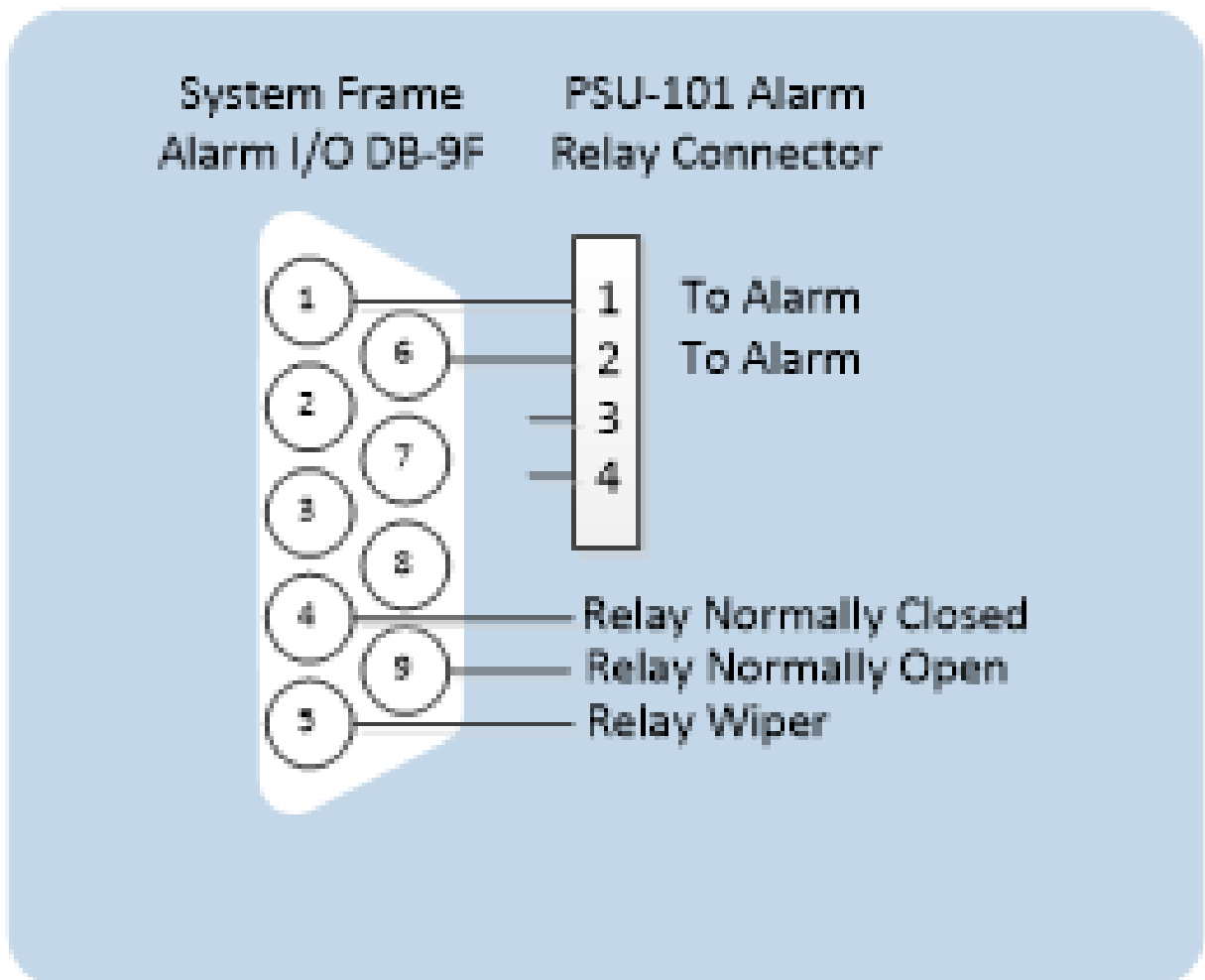

5.10 Connecting to a Four-Wire Audio Device

An external four-wire audio device can be directly connected to a port connector through the four audio pins. If there is excessive noise on the lines between the device and the matrix, the device may be electronically unbalanced with the rest of the system. The device must be isolated with external isolation transformers.

The **CALL SEND** output can be connected to the **CALL REC** input to tell the system software that this is a directly connected port.

EHX allows the changing of the audio output reference level between **-24, -21, -18, -15, -12, -9, -6, -3, 0, +3, +6, +9, +12** and **+14 dB**.

With a **+12dB** output reference level, it is possible to drive a **200 to 400 Ohm** headset directly with a port output for such uses as direct IFB feed.

The EHX configuration software allows the changing of the audio input reference level between **-12, -9, -6, -3, 0, +3, +6, +9, +11 dB**.

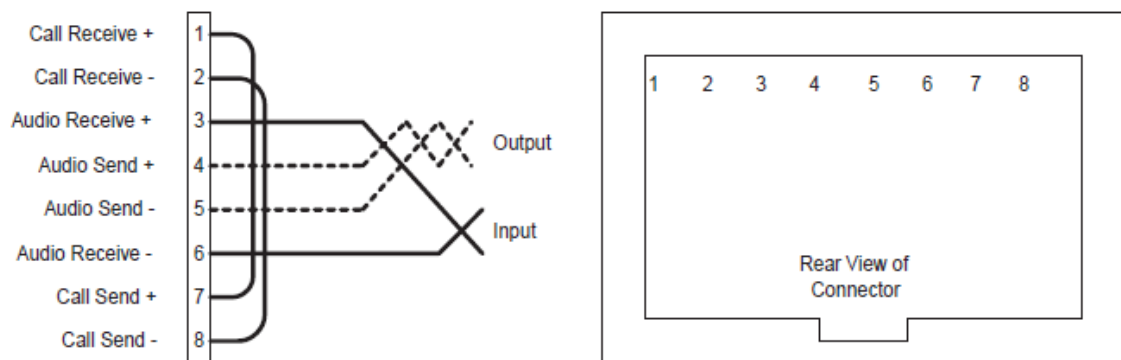

Note: Shielded cable should be used where possible.

5.11 Connecting to Interface Modules

Interface modules convert the four-wire signals of a central matrix port to some other form of communication (such as telephones, camera intercoms, two-way radios, and so on). In this way, non-four-wire devices can communicate with the central matrix.

Each interface module has hardware connectors to connect to **both** the central matrix and to the external device that communicates with the central matrix.

The Eclipse HX-Median has slots for 8 interface modules, in addition to 7 interface cards.

The Eclipse HX-Delta has slots for 3 interface modules, in addition to 4 interface cards.

Clear-Com also offers two types of interface frames, to house interface modules, the IMF-3, and the IMF-102 interface frames. For more information, see [Locating Interface Frame\(s\) and Power Supplies](#).

The following figure shows the pin assignments of RJ-45 connectors when used to connect to interface frames (such as an IMF-3 frame):

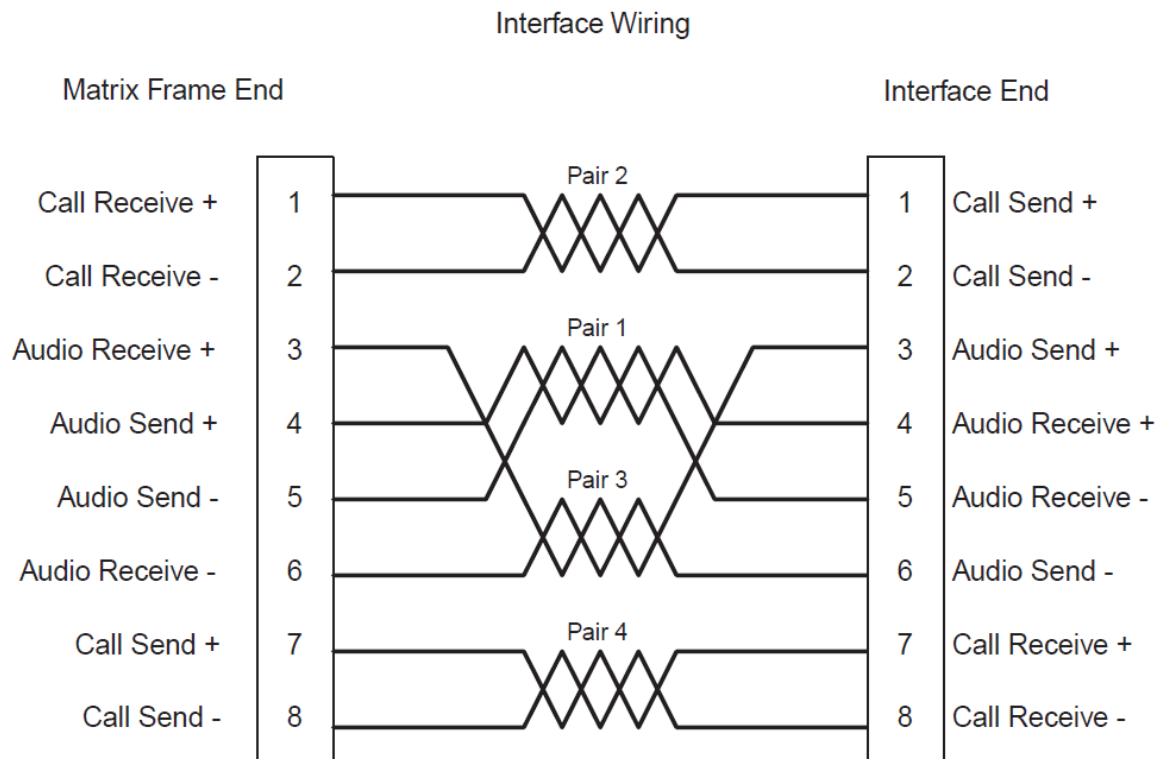

For Eclipse HX-Omega, Eclipse HX-Median and Eclipse HX-Pico, if the GPI/RLY port is used a ferrite core must be added to the socket end of the cable. A suitable ferrite core is **Würth Elektronik part 74271132**.

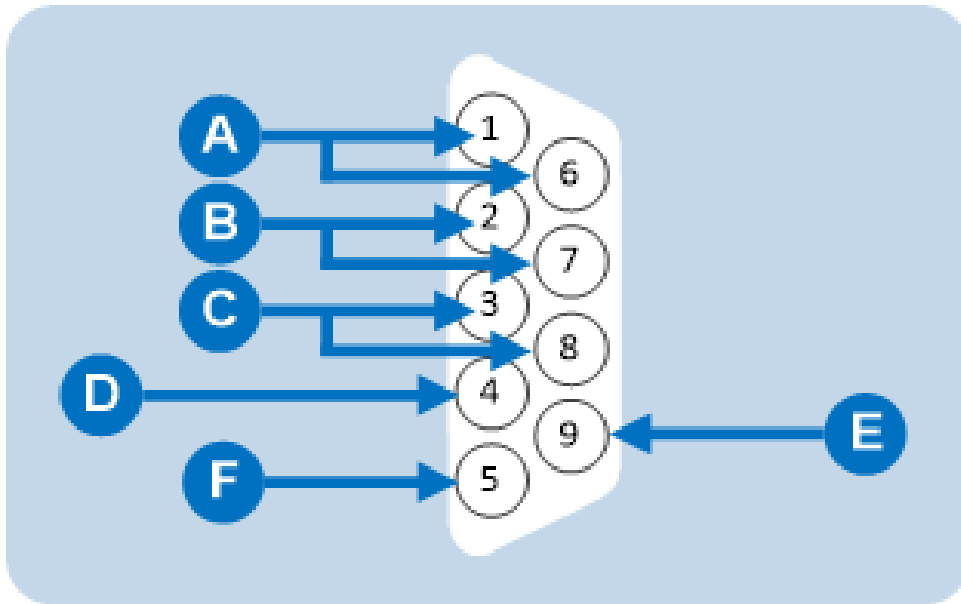

Note: Shielded cable should be used, where possible.

5.11.1 Wiring Schemes for the FOR-22 Interface Module



Pinout of DB-9M I/O connector for FOR-22	
Connector	Description
A	Pin 1 and Pin 6 = Audio output
B	Pin 2 and Pin 7 = Audio input
C	Pin 3 and Pin 8 = Logic input (+ / - 4 to 50V)
D	Pin 4 = Relay normally closed

Pinout of DB-9M I/O connector for FOR-22

	Pin 9 = Relay wiper
	Pin 5 = Relay normally open

The FOR-22 four-wire/radio interface connects two external four-wire circuits to the matrix. Camera intercoms, two-way radios, microwave and satellite links, IFBs, and program audio in and out are candidates for use with the FOR-22.

A FOR-22 interface connects to an Eclipse HX matrix through the two RJ-45 connectors on its rear panel.

The **top** RJ-45 is for the **first channel** of the interface module. The **lower** RJ-45 is for the second channel.

The user side of the FOR-22 for each channel appears on a DB-9M connector on the rear of the IMF-3 or IMF-102 frame. Each channel is **identical**. The following sections describe how to wire for the various types of inputs and outputs available on the DB-9M connector:

- External audio devices.
- Call signal input.
- Relay contacts.

Note: *Shielded CAT5 cable should be used, where possible.*

External audio devices

Connect external audio devices to the FOR-22 ports through the two DB-9M connectors labeled “I/O” on the rear panel. Both the audio input and the audio output are transformer isolated.

Note: *For more information on the various level ranges available on the input and output, see the **FOR-22 Manual**.*

Call Signal Input

The Call Signal input is used to receive a call/logic input signal from an external device and send it to the matrix. The voltage across the pins required to receive a call signal ranges from **4 - 50V**; + / - AC. The input will draw between **4 and 8 mA**.

Relay Contacts

Each FOR-22 interface channel features a relay that is associated with the logical call signal output of a port. A relay's function depends on the function assigned to the FOR-22 port through the EHX configuration software. A relay can be assigned to operate with any label in the system: when that label is activated (either by a talk, listen, or both, as set from the configuration program), the relay will activate.

Note: For more information about configuring a relay, see *EHX Help*.

The relay can be used to activate an external device, such as an applause light in a studio, a cue light, or a security-door lock. The relays feature both **normally open** and normally closed contacts. The contacts are rated at **1 A at 24 VDC**; they are **not** designed for switching mains AC line voltage.

5.11.2 Wiring Schemes for the CCI-22 Interface Module

The CCI-22 interface module connects two 2-wire full-duplex partyline circuits to the matrix .

In the same way as the FOR-22, the CCI-22 dual audio interface module uses both the RJ-45 connectors on its rear panel for connection to the matrix (See also the [Wiring Schemes for the FOR-22 Interface Module](#) section).

The **top** RJ-45 is for the **first channel** of the interface. The **lower** RJ-45 is for the **second channel**. The DB-9Ms are the interface module's audio and control inputs and outputs.

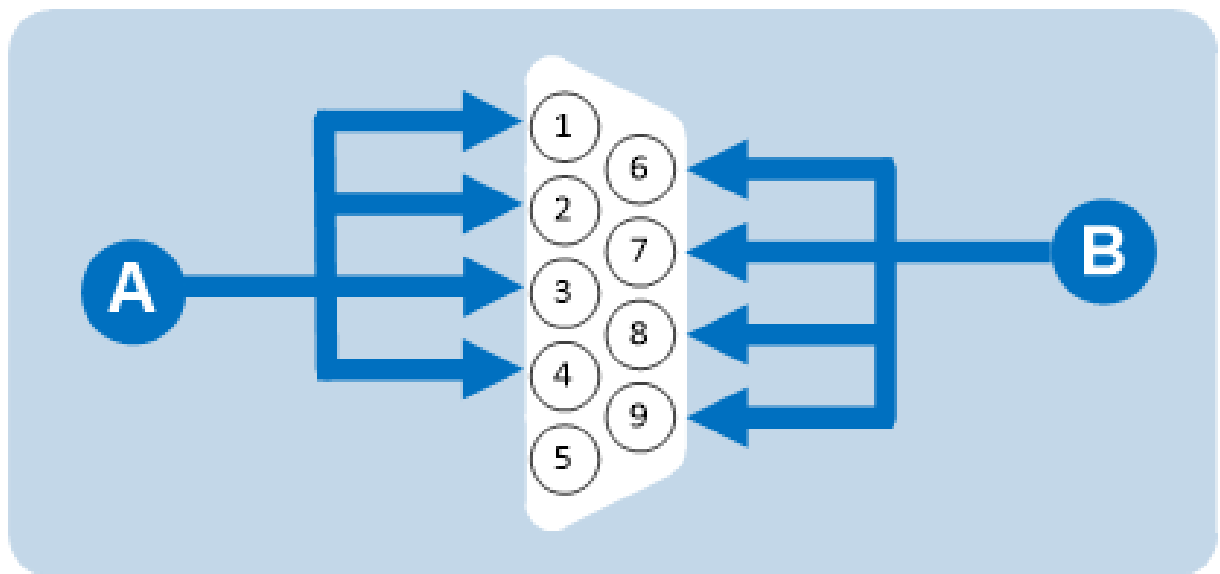

Note: For more information about the CCI-22 interface, see the *CCI-22 Manual*.



The two DB-9M connectors are paralleled such that both partyline channels are available on each connector. It is possible to:

- Wire one DB-9 connector as **Channel #1** and the second DB-9 as **Channel #2**.
- Bring both channels out either DB connector together to create a **TW-type partyline** connection.

DB-9M interface I/O connector for CCI-22

Connector	Description
	Channel #1: Pin 1 = Clear-Com / RTS Pin 2 = Ground Pin 3 = +30 VDC Power Pin 4 = Audio
	Channel #2: Pin 6 = Clear-Com / RTS Pin 7 = Ground Pin 8 = + 30 VDC Power Pin 9 = Audio

Stations on Clear-Com analog partyline systems (such as Encore) connect to each other with two-conductor shielded microphone cable.

One conductor carries the DC power (**28 to 30 V**) for that channel, while the other conductor carries the duplex two-way intercom audio signal plus DC **Call Light** signaling for that channel. The shield acts as common ground for both power and signal for the channel.

Powering the CCI-22 interface module

Power to the CCI-22 interface module channels is provided by the external partyline.

The power connection for each channel is the **+30 VDC Power** pin on the appropriate DB-9M interface I/O connector on the rear-panel assembly. The CCI-22 channel is essentially just another beltpack on the partyline.

The power pin has DC filtering circuitry that provides a high impedance for the audio such that power can be received from a **powered line or TW line**, as is common with RTS systems. For TW operation tie the **AUDIO** and **POWER** pins together.

Terminating the partyline channels

Each partyline channel requires exactly one termination circuit. The termination circuit is usually built into the system component that provides the party line's power. Connecting more than one

termination circuit to a party line will impair the sidetone null and degrade the line's audio quality.

Important note:

When a CCI-22 partyline channel is connected to a Clear-Com partyline, the Clear-Com/RTS Select pin must be left floating.

Grounding this pin selects the RTS mode, which is incompatible with Clear-Com partylines.

5.11.3 Wiring Schemes for TEL-14 Interface Modules

The TEL-14 telephone interface module connects two telephone lines to the matrix. The interface can be used to:

- Establish IFB connections between the main intercom and remote production trucks.
- Link intercom communication between remote systems.
- Enable telephone calls directly to or from any intercom panel in an Eclipse system.

The TEL-14 uses each of the RJ-45 connectors on its rear panel for connection to a matrix port. One RJ-45 is for **Line A** of the interface and the other RJ-45 is for **Line B** of the interface.

The DB-9M connectors are the **Line A** and **Line B** connections to the telephone line. Clear-Com provides DB-9F to RJ-11 adapters so that standard phone line RJ-11 plugs and jacks can connect directly to the interface.



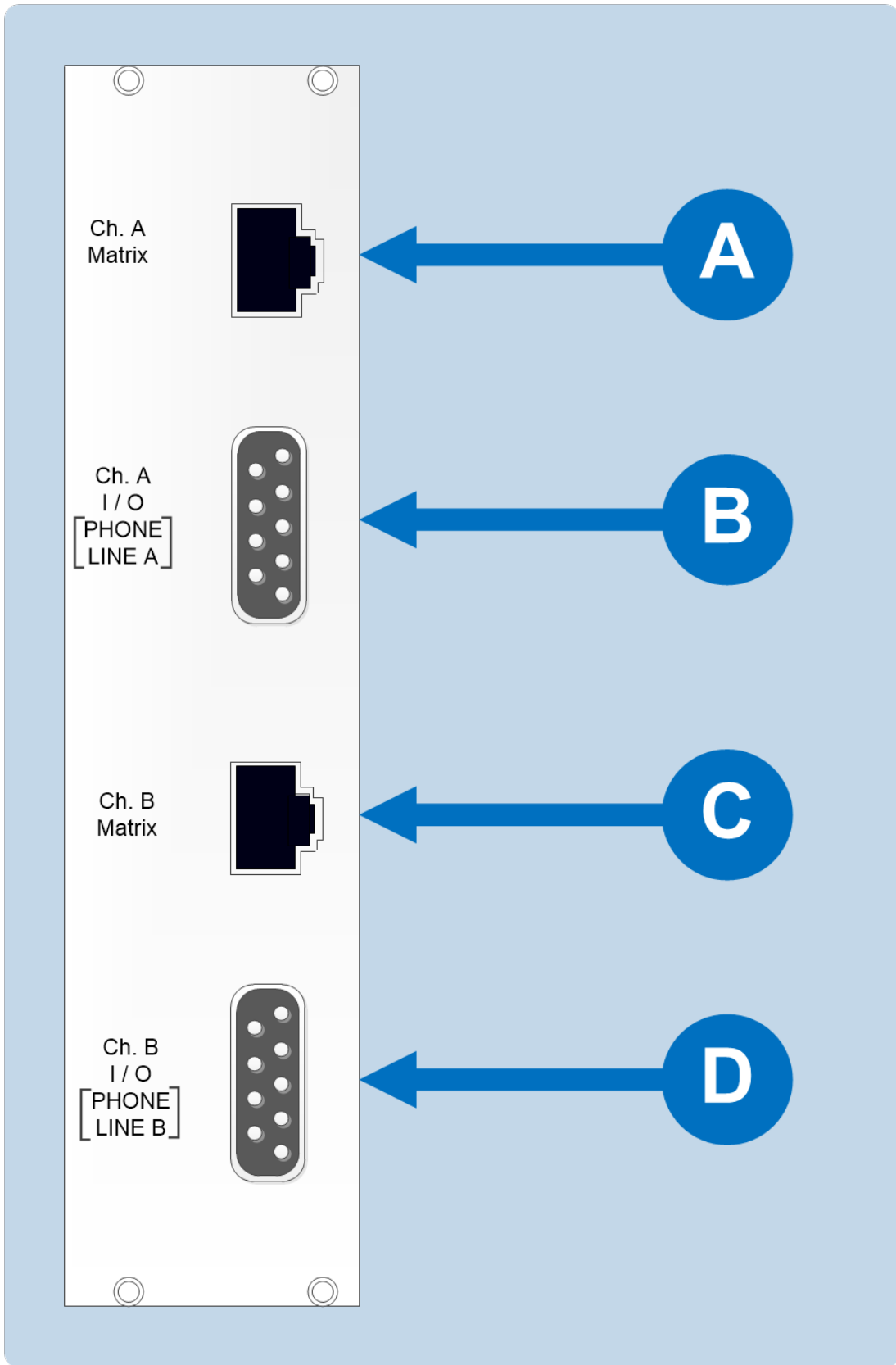

Note: For more information about the TEL-14 interface module, see the **TEL-14 Manual**.

Wiring the TEL-14 interface to an IMF-3 interface frame

On the rear of the IMF-3 frame, there is a separate rear-panel assembly for each interface module, which contains four connectors for each interface.



Wiring an IMF-3 rear panel to a TEL-14 interface module

Connector	Instruction / description
	The upper DB-9M connector is used to connect to the first telephone line, line A .
	The upper RJ-45 connector is then used to connect telephone line A to the matrix.
	The lower DB-9M connector is used to connect to the second telephone line, line B .
	The lower RJ-45 connector is used to connect telephone line B to the matrix.

Note: To allow use of a common RJ-11 terminated telephone line, Clear-Com provides two DB-9F to RJ-11 adapters (Clear-Com part 770025).



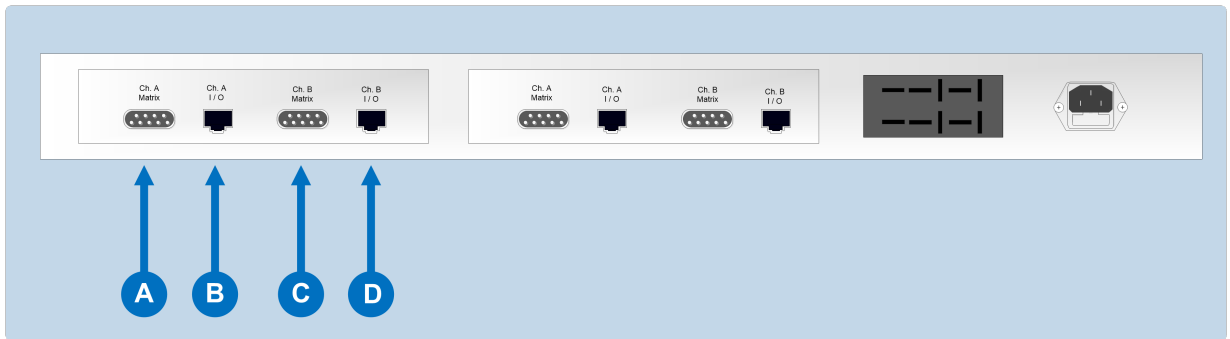

For internal dip-switch settings and adjustments, see the **TEL-14 Manual**.

Wiring a TEL-14 interface to an IMF-102 interface frame

On the rear of the IMF-102, there are two sets of four connectors each, arranged horizontally.



Wiring an IMF-102 rear panel to a TEL-14 interface module

Connector	Instruction / description
	DB-9M connector. Connects to the first telephone line, line A .
	RJ-45 connector. Connects telephone line A to the matrix.
	DB-9M connector. Connects to the second telephone line, line B .
	RJ-45 connector. Connects telephone line B to the matrix.

Note: To allow use of a common RJ-11 terminated telephone line, Clear-Com provides two DB-9F to RJ-11 adapters (Clear-Com part 770025)

For internal dip-switch settings and adjustments, see the **TEL-14 Manual**.

Connecting a TEL-14 interface to the telephone line

Connecting the telephone line can be accomplished with one of two methods:

- Use the **RJ-11 to DB-9F adapters** supplied by Clear-Com with the TEL-14 interface module.
- Directly wire each telephone line to a DB-9F connector using the pinouts as shown in the following figure (which displays the wiring diagram of the **RJ-11 to DB-9F adapter**).

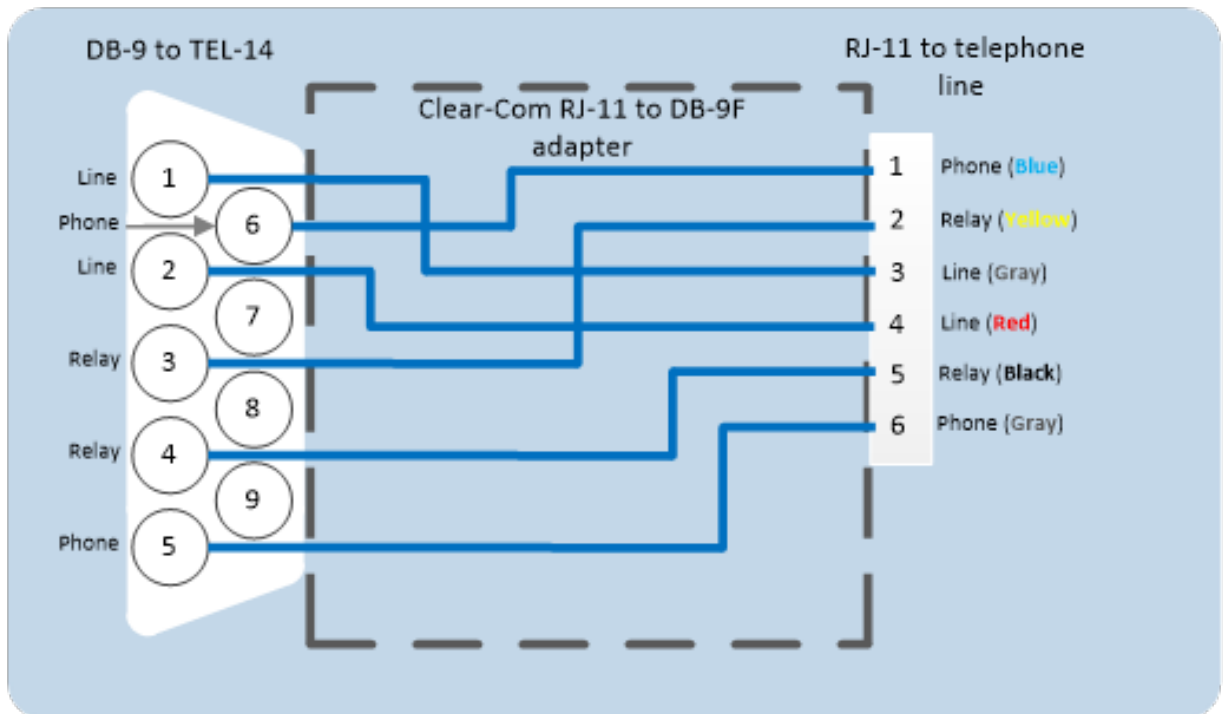

Note: The TEL-14 interface works with telephone company central office (CO) lines. Analog panel lines from some in-house PABXs are not compatible.

Using series-connected telephone sets with the TEL-14

Although it is possible to use a parallel-connected telephone set to originate calls, it is preferable to use a series-connected telephone set with the TEL-14. This prevents the impedance of the telephone set from disturbing the telephone line impedance recognized by the TEL-14.

It will also allow the TEL-14 to automatically disconnect the telephone when it comes “off-hook.” A standard telephone may be installed in series with the TEL-14 by connecting it to pins **1** and **6** of the **RJ-11 jack**. If telephones **must** be connected in parallel with the telephone line(s) during the TEL-14’s automatic nulling process, **all** additional standard telephones must be “on-hook”.

Using relay contacts with the TEL-14 interface

A pair of relay contacts for each telephone line rated at **2A** at **24 VAC** is available on the **DB-9** or the **RJ-11** of the adapter. This pair of contacts is normally open when the line is “on-hook,” and closes when the interface goes “off-hook”.

These contacts are not connected to any other circuitry inside the interface, and can be used to energize a line-in-use indicator light on a standard multiline phone set, or for any other low-power application.

5.11.4 Wiring Scheme for the RLY-6 Interface Module

The RLY-6 interface module provides six fully programmable SPDT (single pole, double throw) relay outputs, to support dedicated switching functions external to the matrix .

RLY-6 interfaces can be:

- Daisy chained to provide connection of up to 60 relays to the matrix.
- Mixed with GPI-6 modules up to the total limit of 60 items.

Five RLY-6 and five GPI-6 modules would provide 30 relays and 30 inputs for a total of 60 inputs and outputs.

Note: *If both GPI-6 and RLY-6 interface modules are used the GPI-6 interface module must be placed first in the daisy chain.*

For more information about wiring the RLY-6, see the **RLY-6 Manual**.

Wiring the RLY-6 to an IMF-3 interface frame

To connect the RLY-6 to the IMF-3 frame:

1. Connect one end of an RJ-45 cable (eight wires with no reversal) into the **GPI/RLY INTERFACE** connector on the back of the matrix.
2. Connect the other end into the top RJ-45 (**CH. A MATRIX**) connector for the RLY-6.

To connect an additional RLY-6 interface to the IMF-3 frame:

1. Connect one end of a short RJ-45 cable into the lower RJ-45 (**CH. B MATRIX**) for the first RLY-6.
2. Connect the other end of the cable into the top RJ-45 (**CH. A MATRIX**) connector for the additional RLY-6.

Additional RLY-6 Interfaces are added in the same way, using daisy-chain wiring. If there are multiple RLY-6 modules, the relays in the first module will be numbered **1 to 6**, the relays in the second module will be numbered **7 to 12**, and so on. **GPI-6** modules can be mixed in this daisy-chained scheme. The maximum combined length of all the RJ-45 cables should **not** exceed 20 feet (6 m).

Rear view of IMF-3 interface frame

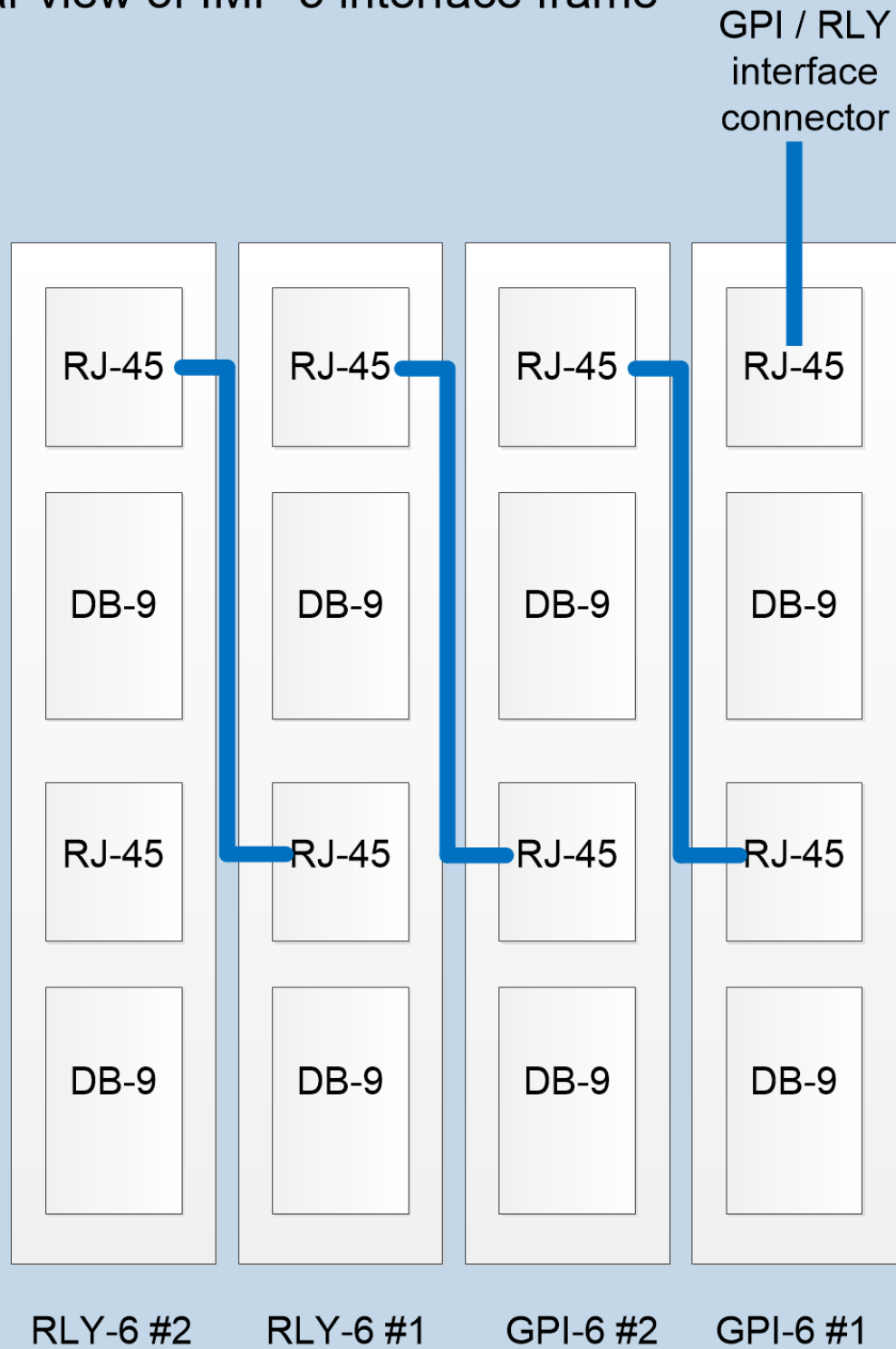

Note: If both GPI-6 and RLY-6 interfaces are used the GPI-6 interfaces must be placed first in the daisy chain

Wiring external devices to an RLY-6 interface module

To connect external devices to an RLY-6 interface module, use the two DB-9M connectors on the rear cable assembly panel for the interface module.

If a DB-9F is plugged into the connector labeled **CH. A I/O**, relays 1 to 3 are available on that connector. The connector labeled **CH. B** has the contacts for relays 4 to 6.

Note In the following image the labels on the pins apply to either connector. For example, #1/4 : **COM** refers to the wiper of **relay 1** if it is connected to **CH. A** and the wiper of **relay 4** if it is connected to **CH. B**.

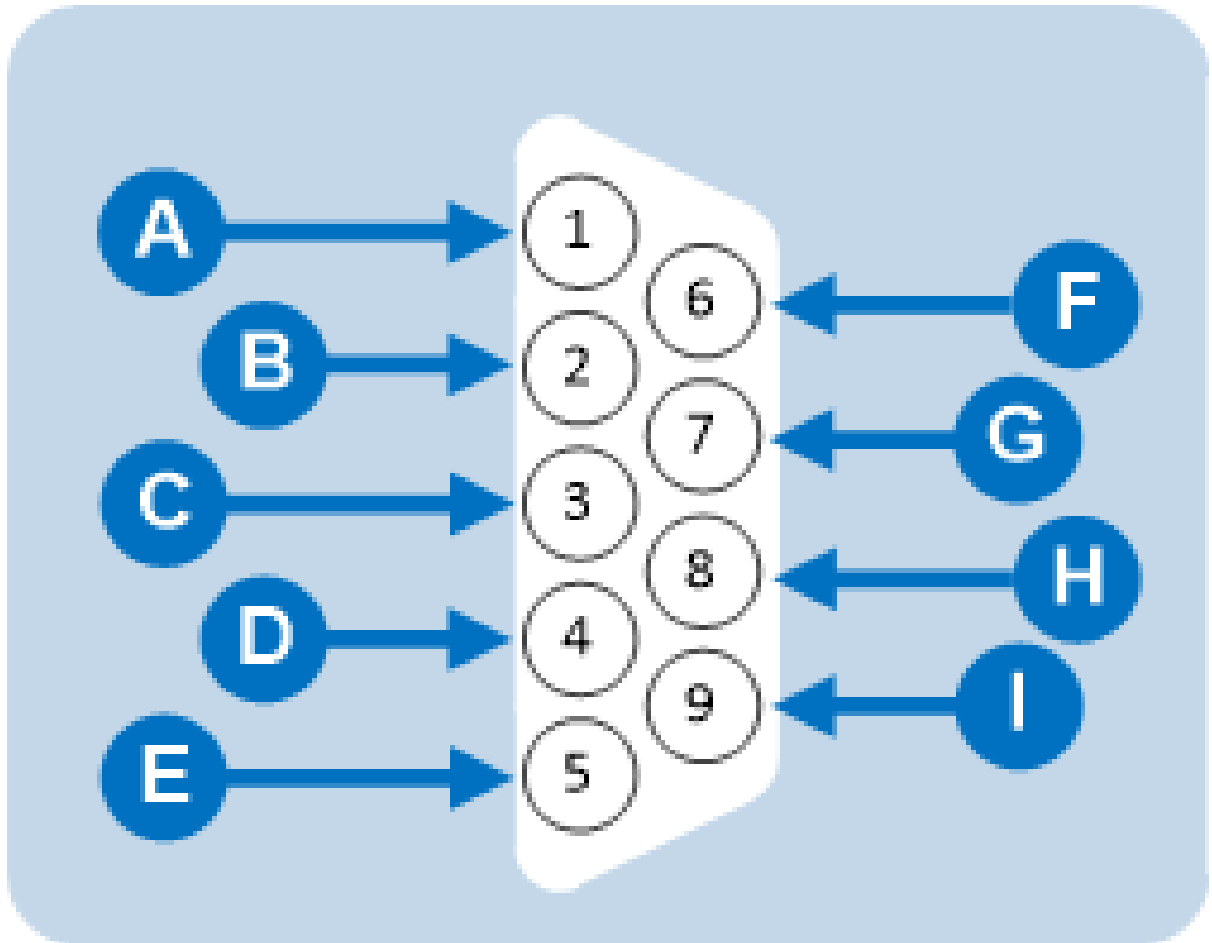



RLY-6 DB-9M connector pinout	
Connector	Description
	#1/4 Normally closed

RLY-6 DB-9M connector pinout

	#1/4 Normally open
	#2/5 COM
	#3/6 Normally closed
	#3/6 Normally open
	#1/4 COM
	#2/5 Normally closed

RLY-6 DB-9M connector pinout

	#2/5 Normally open
	#3/6 COM

Wiring the RLY-6 to an IMF-102 interface frame

The wiring of an RLY-6 interface that is placed in an IMF-102 interface frame is the same as the wiring for a RLY-6 interface placed in an IMF-3 interface frame (see the **Wiring the RLY-6 to an IMF-3 interface frame** image).

The only difference is that an IMF-102 interface frame houses only two interfaces, which are mounted horizontally rather than vertically in the frame.

***Note:** IMF-3 rear panel and IMF-102 rear panel images illustrate the differences between these interface frames.*

For more information, see your **IMF-102** and **IMF-3** documentation.

To associate a relay to a label, use the EHX configuration software (see your **EHX** documentation and **EHX Help**).

5.11.5 Wiring Schemes for a GPI-6 Interface Module

The GPI-6 input interface module provides connection for six programmable inputs to the matrix so that each input can control a predefined matrix function.

Multiple GPI-6 interfaces can be daisy-chained to provide connection of **up to 60 inputs** to the matrix. RLY-6 and GPI-6 modules can be mixed together up to the **total limit of 60 items**.

Five RLY-6 and five GPI-6 modules would provide 30 relays and 30 inputs for a total of 60 inputs and outputs.

***Note:** If both GPI-6 and RLY-6 interface modules are used, the GPI-6 interface modules must be placed **first** in the daisy chain.*

Wiring the GPI-6 to the IMF-3 interface frame

To connect the GPI-6 to the matrix:

1. Connect one end of an RJ-45 cable (eight wires with no reversal) into the **GPI/RLY INTERFACE** connector on the back of the frame.
2. Connect the other end into the top **RJ-45 (CH. A MATRIX)** connector for the **GPI-6**.

To connect an additional GPI-6 Interface module:

1. Connect one end of a short RJ-45 cable into the lower **RJ-45 (CH. B MATRIX)** for the first GPI-6.
2. Connect the other end of the cable into the top **RJ-45 (CH. A MATRIX)** connector for the additional GPI-6.

Additional GPI-6 Interface modules are added in the same way, using daisy-chain wiring. If there are multiple GPI-6 modules used, the inputs in the first will be numbered 1 to 6, second will be 7 to 12, etc.

RLY-6 modules can be mixed in this daisy-chained scheme. The maximum combined length of all the RJ-45 cables should not exceed 20ft. (6m).

Wiring the GPI-6 to external devices

To connect external devices to the GPI-6 interface, use the two DB-9M connectors on the rear cable assembly panel for the interface.



The image below shows the pin assignment of these connectors as viewed from the frame side of the connector.

Notes: *If a DB-9F is plugged into the connector labeled **CH. A I/O**, inputs 1 to 3 are available on that connector.*

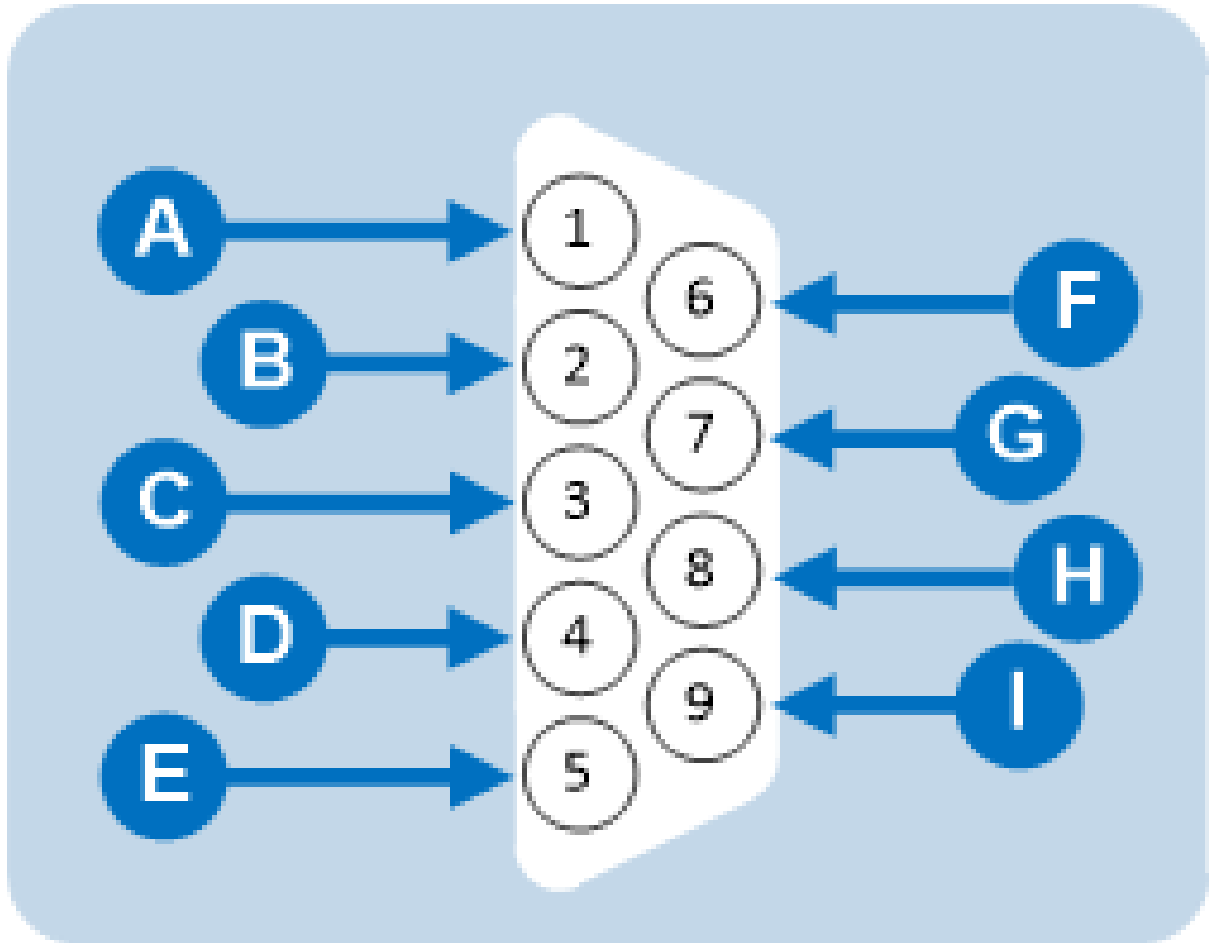
*The connector labeled **CH. B I/O** has inputs 4 to 6. In the image below, the labels on the pins apply to either connector.*



GPI-6 DB-9M connector pinout

Connector	Description
	#1/4 Input A
	#2/5 Input A

GPI-6 DB-9M connector pinout

	#3/6 Input A
	Ground
	Ground
	#1/4 Input B
	#2/5 Input B
	#3/6 Input B
	Power source

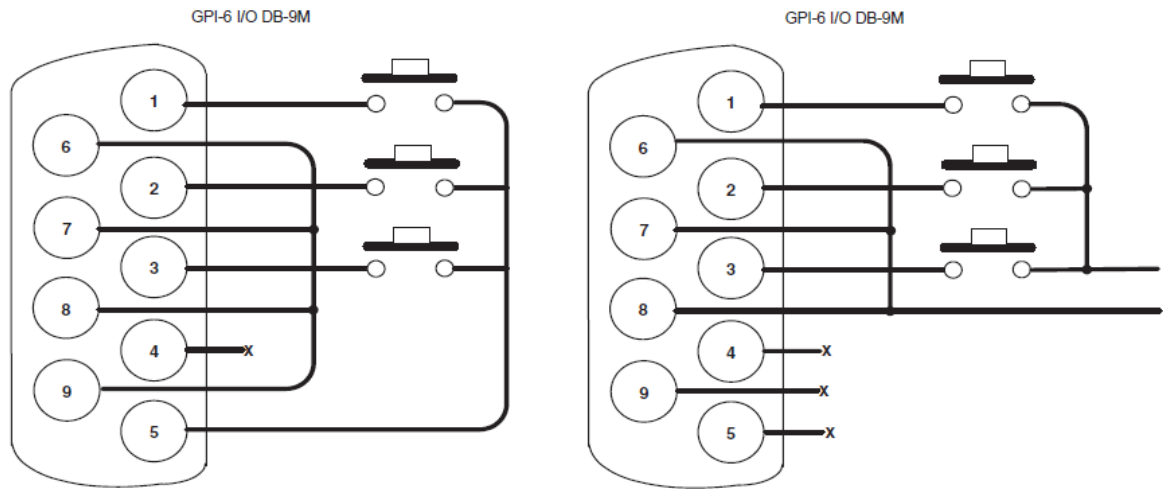

The image above shows you how to connect switches or contacts using the power source provided by the GPI-6 module or powering switches from external sources. Each input can be wired to be isolated from each other as a further variation.

Wiring the GPI-6 to an IMF-102 interface frame

The wiring of a GPI-6 interface that is placed in an IMF-102 interface frame is the same as the wiring for a GPI-6 interface placed in an IMF-3 interface frame.

The only difference is that an IMF-102 interface frame houses only two interfaces, and they are mounted horizontally rather than vertically in the frame.

Note: *The IMF-3 rear panel and IMF-102 rear panel images show the differences between these interface frames.*

For more information, see your **IMF-102** and **IMF-3** documentation.

Note: *To define an input function, use the EHX configuration software.*

6 Connecting Matrices

You can connect your Eclipse HX matrices together, to expand the geographical range or the port density of a system. You can connect:

- Up to 64 Eclipse HX matrices (Eclipse HX-Omega, Eclipse HX-Median, Eclipse HX-Delta and Eclipse HX-PiCo) using **trunk lines** and an **Ethernet network**.
- Eclipse HX-Omega, Eclipse HX-Median and Eclipse HX-Delta matrices using **E-FIB** fiber interface cards and **fiber-optic** cable.
- Two Eclipse HX-PiCo matrices, using the **PiCo-Link** connector, to create non-blocking access to all audio ports on the two matrices.

Note: For an overview of the entire installation process, see [Installation Overview](#).

6.1 Intelligent Linking

Intelligent linking dynamically allocates the available audio trunks as required when a **talk** or **listen** to another matrix system is requested. The Ethernet connection between matrices allows control data to route the audio lines so that any panel or interface on one matrix can communicate with panels or interface ports on the other matrices.

By doing so, the matrix can transparently handle communication requests so that an intercom panel user cannot distinguish between talking to a control room next door or across the continent. The Ethernet network extends the system's programming ability as well, because one computer on a network can control and monitor all matrices on the network.

Intelligent linking uses up available ports on the matrix, which means that it does **not** provide 100% routing. This type of connection is suitable:

- When only a restricted amount of inter-matrix communications is required (for example, when connecting studios).
- For wide area communications, such as remote systems that use public telecommunications networks, where only a small number of trunks are required.

Note The matrices are configured for linking using EHX. For more information, see your **EHX : documentation** (including **EHX Help**).

6.1.1 Intelligent Linking with Trunk Lines

As many as 64 separate Eclipse HX-Omega, Eclipse HX-Median, Eclipse HX-Delta and Eclipse HX-PiCo matrices can be intelligently linked, using dedicated audio trunk lines and an Ethernet network. Audio travels between the matrices on the dedicated trunk lines, while control data travels on the Ethernet network.

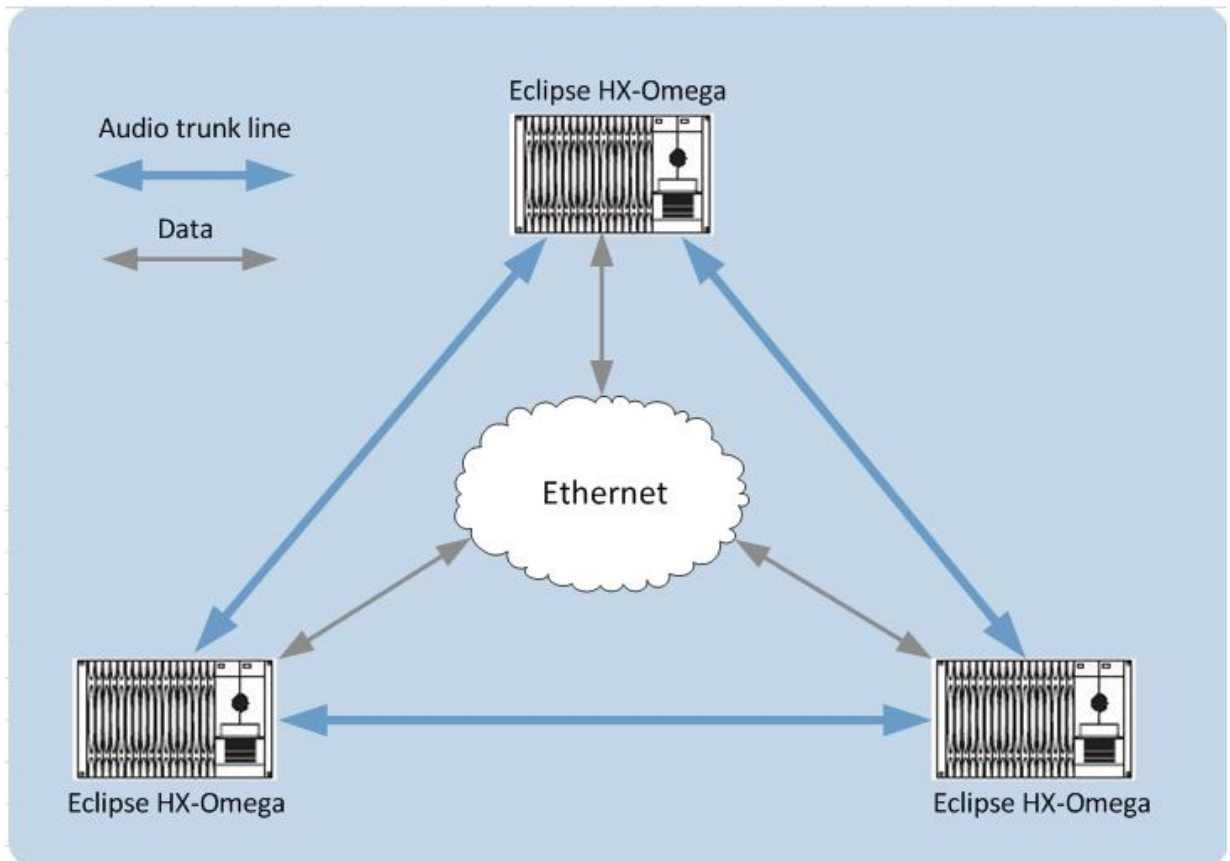

You can connect a dedicated audio trunk line using:

- The **receive** lines of an MVX-A16 serial port on one matrix and the appropriate **send** lines of an MVX-A16 serial port on the second matrix.
- An E-QUE interface module, or an E-FIB (Fiber) card and fiber optic cables.

Note Only Eclipse HX-Median, Eclipse HX-Omega and Eclipse HX-Delta matrices can be connected using E-QUE / E-FIB cards and fiber optic cables.

6.1.2 Serial port to serial port linking

A specialised RJ-45 to RJ-45 jumper cable is required for serial port to serial port connections. You can either construct such a cable or use a punch-down block for the crossover wiring (see the image below).

The matrix is connected to an Ethernet network with the RJ-45 sockets labeled:

- **LAN 1** and **LAN 2** on the rear of the Eclipse HX-Omega, Eclipse HX-Median or Eclipse HX-Delta.
- The RJ-45 socket labeled **LAN** on the rear of the Eclipse HX-PiCo.

Note: Also applies to the E-32 matrix, the immediate predecessor of the Eclipse HX-PiCo.

The connectors have standard Ethernet pin assignments (see the images and table below).

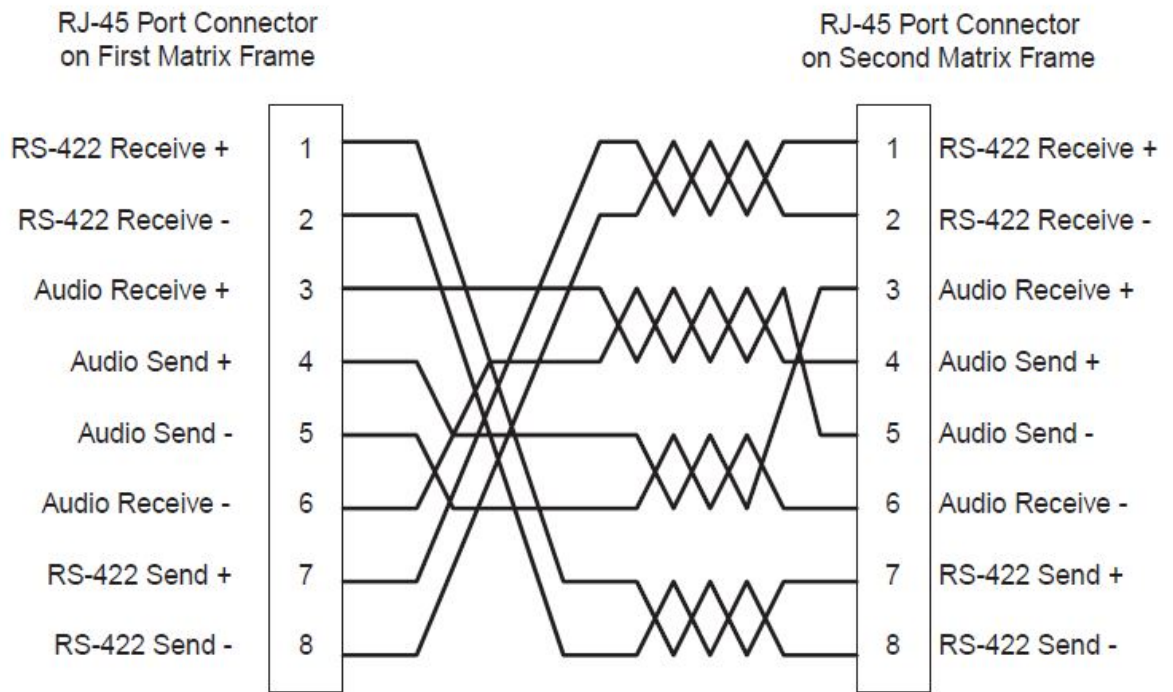

LAN1 and LAN2

Ethernet RJ-45 Connectors

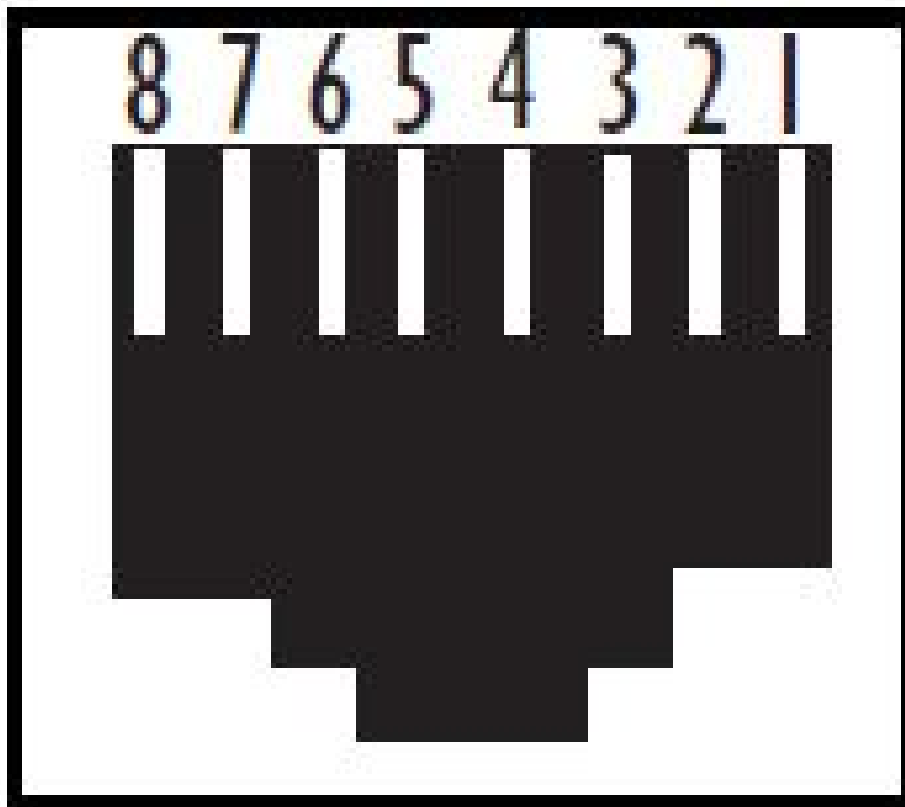

Pin	Description
Pin 1	Transmit data +
Pin 2	Transmit data -
Pin 3	Receive data +
Pin 4	Unused
Pin 5	Unused

Pin	Description
Pin 6	Receive data -
Pin 7	Unused
Pin 8	Unused

6.2 Linking Eclipse HX-Pico Matrices with the PiCo-Link

You can create one non-blocking 64 port Eclipse HX system by connecting two Eclipse HX-PiCo matrices together, using the **PiCo-Link** RJ-45 connectors on the matrices.

This type of connection gives each connected matrix access to all of the audio ports of both matrices without using up ports for trunk lines (although logical routing such as IFBs, Telephone handling and ISOs **cannot** be used across the matrices).

To make this connection, use a specially constructed screened CAT5 cable of maximum length 1 meter (3.28 feet). The cable is wired as shown in the next table.

Cable End 1	Wire color	Cable End 2
Pin 1	White / orange	Pin 3
Pin 2	Orange	Pin 6
Pin 3	White / green	Pin 1
Pin 4	Blue	Pin 4
Pin 5	White / blue	Pin 5
Pin 6	Green	Pin 2
Pin 7	White / brown	Pin 7
Pin 8	Brown	Pin 8

Notes *Hopping is not supported. DTMF generaton and detection is only supported on 16 ports : (ports 17 – 32) on each Eclipse HX-PiCo. The last four ports on an Eclipse HX-PiCo matrix are four-wire ports, and not available for panel connections.*

*The matrices are configured for linking using EHX. For more information, see your **EHX documentation** (including **EHX Help**).*

6.3 Tie-Line (Audio Only) Linking

You can directly connect two Eclipse HX matrices through tie-line linking.

By configuring each of the linked ports in each system as a partyline, the two systems can talk and listen to anyone on that partyline in either system. Call signals will also pass from one system to the other.

However, since no control data passes between the matrices, assignments cannot be dynamically allocated among the ports of a matrix. Only the one partyline on the first matrix connects to the partyline of the second matrix.

6.4 E1 / T1 Linking

The E-QUE interface card, which can be fitted to the Eclipse HX-Omega, Eclipse HX-Median and Eclipse HX-Delta matrices, can be used to provide:

- Direct E1 to E1 port connections.
- Trunk linking, using a network between systems.
- T1 trunking between Eclipse HX systems, and between Eclipse HX systems and compatible third-party equipment.

Notes: You can also use the E-QUE card for E & M signaling. For more information, see [E M Signalling with an E-QUE E1 / T1 Interface Card](#).

For more information about the E-QUE interface card, and other Clear-Com interface cards, see either:

- *The Eclipse HX-Omega User Guide.*
- *The Eclipse HX-Median User Guide.*
- *The Eclipse HX-Delta User Guide.*

6.4.1 E1 Trunk Connections

You can use the E-QUE interface card to make E1 connections between Eclipse systems or between Eclipse systems and compatible third-party equipment.

E1 mode provides 30 channels of G.722 encoded audio available on each of ports 1 and 5, giving 60 channels per card.

The **E1 specifications** are:

- HDB3 Encoding.
- Long Haul Receive Signal Level.

- E1 120 Ohm Transmit Pulse Amplitude.
- Balanced.
- 120 Ohm Line Impedance.
- No Signaling.
- G.722 64 kbit/s Audio Encoding.
- Tx Clock locally generated.
- Rx Clock Line Recovered.

The following image shows **Matrix to Matrix direct E1 Trunking**, using a direct connection between the matrices using a CAT5 crossover cable. The E-QUE interface should be set to **E1 Direct** in EHX hardware setup.

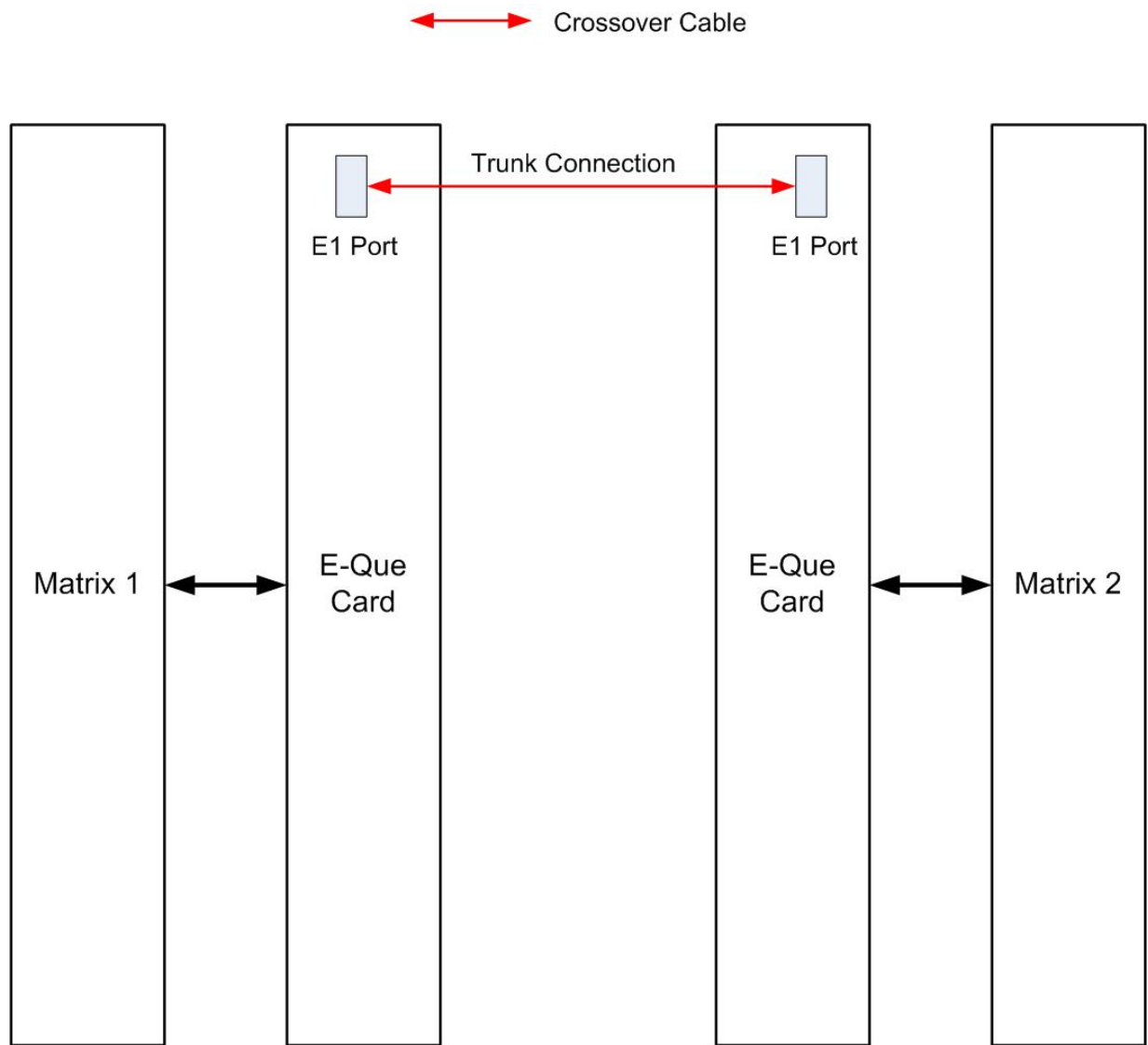

E1 trunking between matrices can also be achieved over an E1 network, as shown.

For **E1 Trunking with an E1 Network**, E1 ports 1 and 5 of the E-QUE interface are connected using standard straight-through CAT5 cables rather than crossover CAT5 cables.

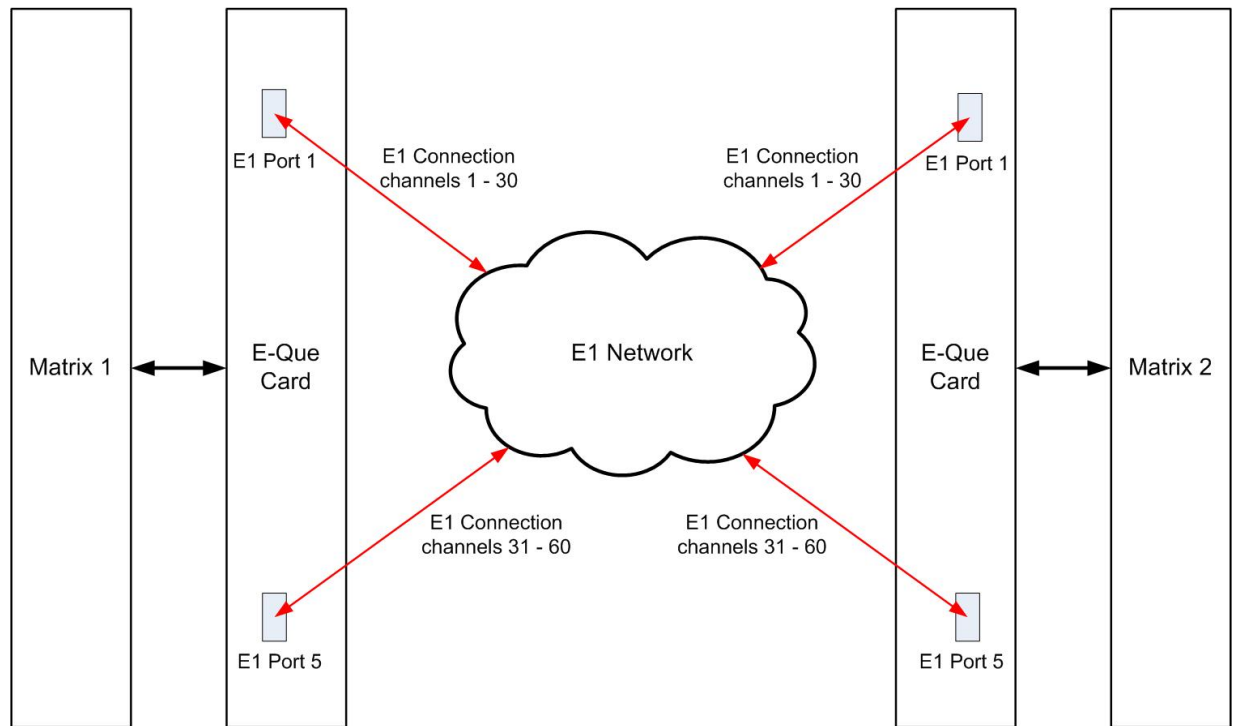

The E-QUE interface can also be used to connect the matrix to third party equipment using E1 port 1 or 5.

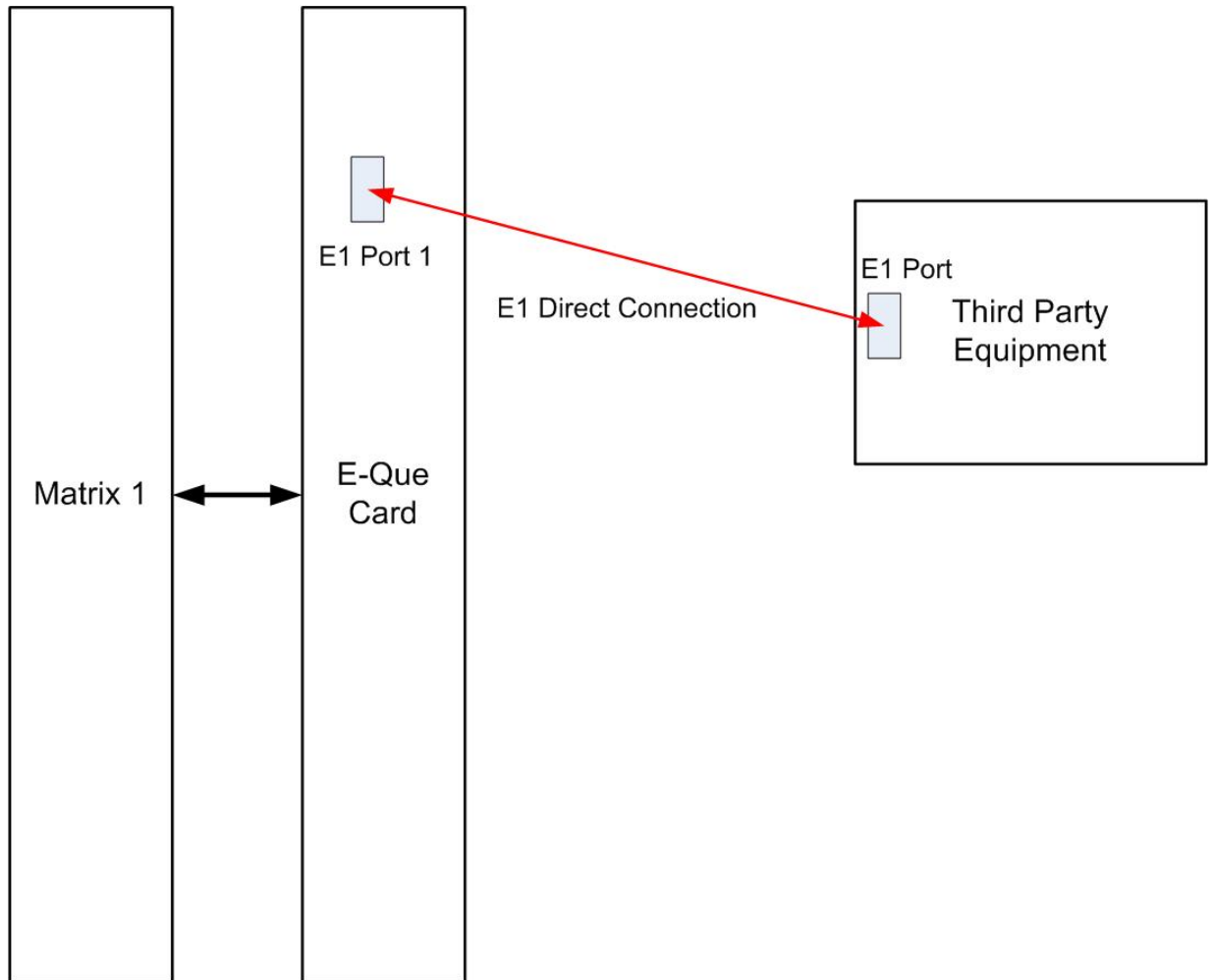

The CAT5 cable connecting the E1 port on the E-QUE rear card may be a crossover cable or a straight-through cable depending on the requirements of the third-party equipment. The E-Que interface should be set to **Direct** in EHX.

6.4.2 T1 Trunking

The E-QUE interface card can provide T1 trunking between Eclipse HX systems and between Eclipse HX systems and compatible third-party equipment.

T1 mode provides 24 channels of G.722 encoded audio are available on each of ports 1 and 5, giving 48 channels per card.

The T1 trunking specifications are:

- B8ZS Encoding.
- Extended Super Frame.
- Long Haul Receive Signal Level.
- T1 Long Haul (LBO 0 dB) Transmit Pulse Amplitude.

- Balanced.
- 120 Ohm Line Impedance.
- No Signaling.
- G.722 64 kbit/s Audio Encoding.
- Tx Clock locally generated.
- Rx Clock Line Recovered.

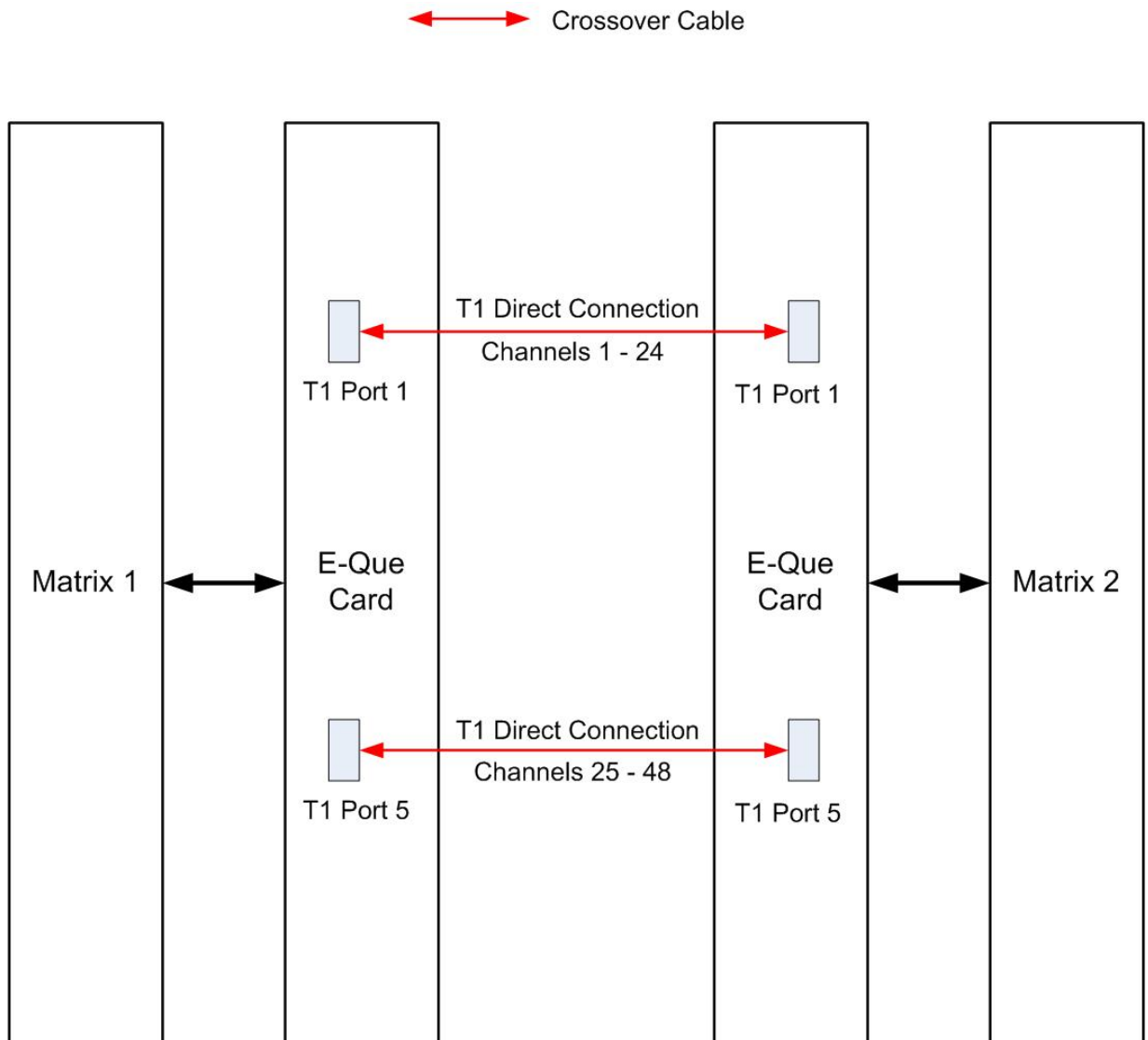

T1 trunking between matrices can also be achieved over a E1 network as shown in the image below.

In this case T1 ports 1 and 5 of the E-QUE rear card are connected using standard straight-through CAT5 cables rather than crossover CAT5 cables.

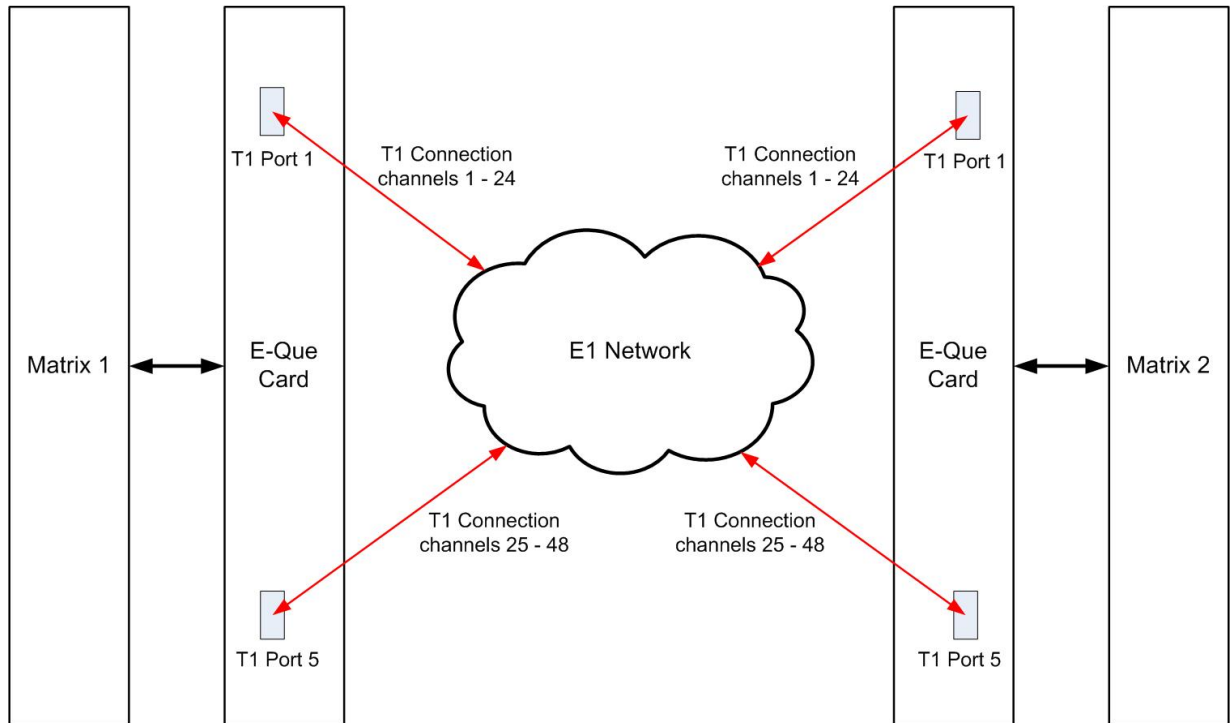

E1/T1 trunking failover

Where the E1/T1 trunking has been configured with redundant trunks audio will be switched from the primary trunk to the backup trunk when a failure is detected.

When failover occurs from primary to backup there will be a three second audio break on any route running over the trunk.

If the trunk routing is later switched back from the backup trunk to the primary trunk there will be no loss of audio.

6.5 Fiber-Optic Linking

The E-FIB interface card is the fiber-net interface for the Eclipse HX-Omega, Eclipse HX-Median and Eclipse HX-Delta matrices. The card is supplied with main and backup fiber rings.

Note For more information about the E-FIB interface card, and other Clear-Com interface cards, see the:

- *Eclipse HX-Omega User Guide*
- *Eclipse HX-Median User Guide*
- *Eclipse HX-Delta User Guide*

Each fiber card link comprises:

- A front card with status indicators.
- A rear card with two Duplex LC terminated fiber optic connectors (TXVRA and TXVRB).

E-FIB cards use **9/125 μ single mode fiber optic cables**. On the rear card, the TX1/RX1 connector is used for the main ring and the TX2/RX2 connector is used for the secondary ring.

Note: *The standard maximum node length for fiber card connections is 10km, but other distances are available to special order.*

The order of the fiber optic cable connections is reversed between the front and rear panels:

- On the front panel the primary connection is the upper set of indicators. The secondary connection is the lower set of indicators.
- On the rear panel the lower connector is the primary connection. The secondary connection is the upper connector.

Care should be taken when connecting or disconnecting the cables to ensure that they are connected correctly and not reversed.



A **protective plug** is usually fitted to the fiber connector sockets to protect them from damage or the entry of foreign materials. These should only be removed in order to fit the fiber optic cable. They should be replaced if the cable is unplugged.

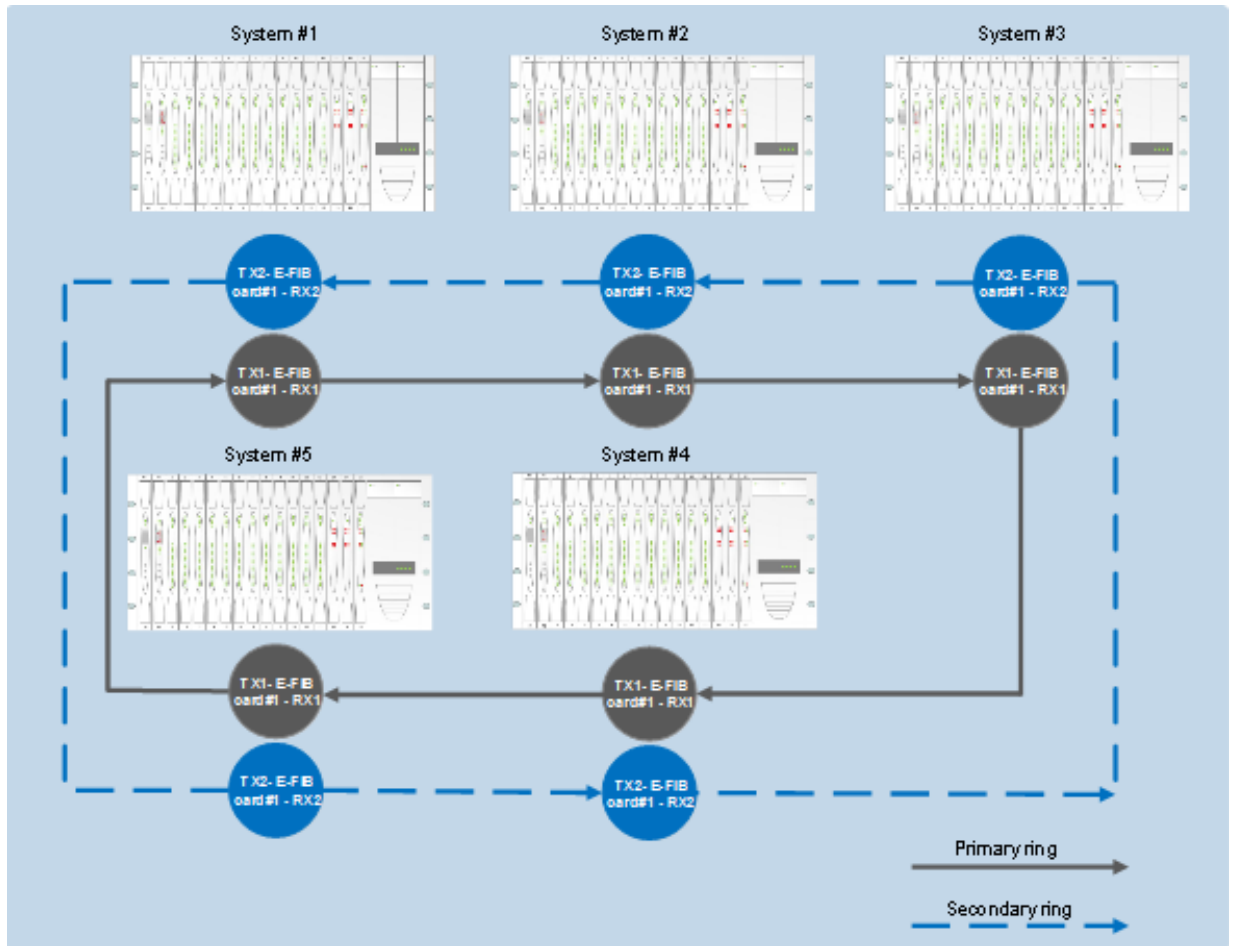

7

Glossary

GlossaryTerm	Definition
Agent IC	Mobile client for Android and iOS that gives remote panel functionality.
Analog Port	<p>Any of the Eclipse HX matrix's analog input/output RJ-45 connectors that are used to connect cable from the matrix to panels and interfaces.</p> <p>Each port connects to a separate audio channel in the matrix.</p>
Alias label	A label that is temporarily assigned and replaces a previously labeled port or conference.
Bus	A bus is the channel or path between the components in the matrix along which electrical signals flow to carry information from one component to the next. In the Eclipse HX matrix the bus is located in the etched surface of the midplane.
Call signal	A call signal is an electronic signal sent from one panel or interface to another. A call signal can be audible and/or visual. Typically a call signal is sent to get the attention of a panel operator who may have turned down their intercom speaker's volume or removed their headset. It can also be sent to activate an electronic relay.
Category-5 (CAT5) cable	EIA/TIA 568 category specification relating to network cabling. Shielded category-5 cabling is required for Eclipse HX matrix wiring.
Central matrix	<p>The term central matrix is used to differentiate the central hardware and software of the intercom system from the connected audio devices. The central matrix consists of:</p> <ul style="list-style-type: none"> • The metal housing for the circuit cards and power supplies. • The circuit cards. • The power supplies. • The rear panel connectors which connect the matrix's hardware to panels and interfaces.

GlossaryTerm	Definition
Conference	An internal matrix virtual partyline, channel or busbar where many panels and interfaces can talk onto or listen from the party line without talking to themselves.
Destination	A device such as an intercom panel, beltpack, or interface to which audio signals are sent. The device from which audio signals are sent is called a source .
Duplex	All real-time communication between individuals talking face to face is full duplex, meaning that they can both talk and listen simultaneously. The Eclipse HX matrices provide full-duplex audio.
EHX	EHX is the Eclipse HX configuration software. EHX guides the operation of the matrix circuit cards and connected panels.
Ethernet	International standard which describes how information is transmitted across a network. Provides for the efficient organization of network components.
Fiber optic cable	A fiber-optic cable consists of a glass core covered with a reflective material called cladding and several layers of buffer coating to protect the cable from the environment. A laser sends light pulses through the glass core to the other end of the cable.
FreeSpeak II™	Digital wireless communications product.
Full duplex	Refers to transmission of signals in two directions simultaneously.
Hopping	Refers to making a trunk connection through other matrices to a destination matrix.

GlossaryTerm	Definition
IFB	<p>Interruptible Foldback. The term foldback refers to sending program audio / feed, or some other audio mix, back to announcers while they are on the air. Doing so allows announcers to monitor themselves, other announcers, videotapes of commercials, or some mix of sources, while they on the air. This is typically found in television news and live broadcast events.</p> <p>Announcers typically wear a small ear piece so they can hear the selected foldback audio mix. When a director wants to give directions to an announcer on air, or to announce changes in the program, the director must interrupt the foldback. To do this, the director uses a channel specifically set up to interrupt the foldback audio.</p>
Interface module	<p>A piece of electronic hardware designed to convert the four-wire signals of a central matrix port to some other form of communication, such as 2-wire partyline, telephone, etc. The interface module is connected to a central matrix port. The external non-four-wire device is then connected to the interface module.</p>
I-Series	<p>The I-Series is a family of Eclipse HX-supported user panels. The series includes two display stations, two non-display stations, two expansion panels, and a level-control panel. Eclipse HX also supports V-Series panels (see below).</p>
ISO	<p>The ISO function, short for panel ISolation, allows a panel operator to call a destination and interrupt all of that destination's other audio paths and establish a private conversation. When the call is completed the destination's audio pathways are restored to their original state before the interruption.</p>
Keygroup	<p>KeyGroups provide a way of assigning a label to multiple panels simultaneously even within a networked matrix system. Once the KeyGroups have been defined using EHX, all the keys within a KeyGroup can be changed with a single assignment in Dynam-EC.</p>

GlossaryTerm	Definition
Label	<p>A label is an alphanumeric name of up to five characters that identifies a source, destination, or control function accessed by an intercom panel. Labels appear in the displays of the intercom panel.</p> <p>Labels can identify panels, ports interfaced to other external equipment, fixed groups, party lines, and special control functions.</p>
MADI	<p>Multichannel Audio Digital Interface. The MADI or AES10 electronic communications protocol defines the data format and electrical characteristics of an interface carrying multiple channels of digital audio.</p>
Multiplexing	<p>The process by which two or more signals are transmitted over a single communications channel. Examples include time division and wavelength division multiplexing.</p>
Non-volatile Memory	<p>Data stored in the CPU's firmware (ROM) that is not lost when the power is turned off.</p>
Palette	<p>The port, keyGroup and Monitor selection screen in Dynam-EC.</p>
Panel	<p>Any intelligent intercom device connected to the rear-panel analog ports of the central matrix. This term does not refer to devices connected through interface modules.</p>
Partyline	<p>A wired shared communication system based on a single screened pair of wires. See the Encore range. Matrix requires the CCI-22 to interface to it.</p>
Port	<p>Any of the input/output connections (RJ-45 connectors) on the back panel of the central matrix. These connectors and the attached cables connect the central matrix to remote intercom devices. The term port emphasizes that the connection is a portal between the central matrix and the remote intercom devices.</p>
Program	<p>Any separate audio source that is fed into the intercom channels. In television applications, for example, the program audio is the audio that is broadcast on air.</p>

GlossaryTerm	Definition
Rack Unit (RU)	Standardized unit of mounting space on a rack panel. Each rack unit is 1.75 inches (44.45 mm) of vertical mounting space. Therefore 1 RU is 1.75 inches (44.45 mm) of vertical mounting space, 2 RU is 3.5 inches (88.9 mm), 3 RU is 5.25 inches (133.35mm), and so on.
Remote panel	Any intelligent intercom device connected to the back-panel ports of the matrix. This term does not refer to devices connected through interfaces.
Sidetone	The sound of the panel operator's voice, as heard in their own earphone(s) as they speak.
Source	In this guide, the term source refers to a device (such as an intercom panel, interface, or beltpack) that sends audio into the matrix. The device to which audio is sent is called a destination.
VOX	In the Eclipse HX system, when audio at a panel exceeds a threshold, a light switches on at the panel's port card to visually cue the operator. The threshold level is set in the EHX configuration software.
V-Series	User panels used with Eclipse HX systems, providing advanced intercom facilities. Available in rack mount and desktop formats. I-Series user panels are also supported (see above).

8 Limited Warranty

Clear-Com warrants that at the time of purchase, the equipment supplied complies with any specification in the order confirmation when used under normal conditions and is free from defects in workmanship and materials during the warranty period.

During the warranty period Clear-Com, or any service company authorized by Clear-Com, will in a commercially reasonable time remedy defects in materials, design, and workmanship free of charge by repairing, or should Clear-Com in its discretion deem it necessary, replacing the product in accordance with this limited warranty. In no event will Clear-Com be responsible for incidental, consequential, or special loss or damage, however caused.

8.1 Warranty Period

The product may consist of several parts each covered by a different warranty period. The warranty periods are:

- Cables, accessories, components, and consumable items have a limited warranty of 90 days.
- Headsets, handsets, microphones, and spare parts have a limited warranty of one year.
- UHF wireless IFB products have a limited warranty of one year.
- UHF wireless intercom systems have a limited warranty of three years.
- All other Clear-Com and Drake brand systems and products, including beltpacks, have a limited warranty of two years.

The warranty starts at the time of the product's original purchase. The warranty start date for contracts which include installation and commissioning will commence from the earlier of date of the Site Acceptance Test or three months from purchase.

8.2 Technical Support

To ensure complete and timely support to its customers, Clear-Com's User Support Center is staffed by qualified technical personnel. Telephone and email technical support is offered worldwide by the User Support Center.

The User Support Center is available to Clear-Com's customers during the full course of their warranty period. Telephone support during the warranty period will be offered at no charge between 09:00 and 17:00 according to the customer's local time zone.

In addition, for customers who purchase an Extended Warranty or Service Contract, 24-hour customer support is offered immediately upon purchase of such agreement. For more information, contact your authorized dealer, distributor, or sales representative.

Instructions for reaching Clear-Com's User Support Centers are given below.

Americas and Asia-Pacific Headquarters California, United States

Tel: +1.510.337.6600

Email: CustomerServicesUS@clearcom.com

Europe, Middle East, and Africa Headquarters Cambridge, United Kingdom

Tel: +44 1223 815000

Email: SalesSupportEMEA@clearcom.com

Canada Office Quebec, Canada

Tel: +1 (450) 653-9669

China Office Beijing Representative Office Beijing, P.R.China

Tel: +8610 65811360 / 65815577

Once the standard warranty period has expired, the User Support Center will continue to provide telephone support if you have purchased an Extended Warranty or Service Contract. In these cases, you will have access to telephone support 24 hours per day, 7 days per week.

8.3 Warranty Repairs and Returns

Before returning equipment for repair, contact a User Support Center to obtain a Return Material Authorization (RMA). Clear-Com representatives will give you instructions and addresses for returning your equipment. You must ship the equipment at your expense, and the support center will return the equipment at Clear-Com's expense.

For out-of-box failures, use the following contact information:

Americas and Asia-Pacific Headquarters California, United States

Tel: +1.510.337.6600

Email: CustomerServicesUS@clearcom.com

Europe, Middle East, and Africa Headquarters Cambridge, United Kingdom

Tel: +44 1223 815000

Email: SalesSupportEMEA@clearcom.com

Canada Office Quebec, Canada

Tel: +1 (450) 653-9669

China Office Beijing Representative Office Beijing, P.R.China

Tel: +8610 65811360 / 65815577

Clear-Com has the right to inspect the equipment and/or installation or relevant packaging.

8.4 Non-Warranty Repairs and Returns

For items not under warranty, you must obtain an RMA by contacting the User Support Center. Clear-Com representatives will give you instructions and addresses for returning your equipment.

You must pay all charges to have the equipment shipped to the support center and returned to you, in addition to the costs of the repair.

8.5 Extended Warranty

If you purchase an Extended Warranty, you are also given access free of charge to the User Support Center 24 hours a day, 7 days a week.

You can purchase an extended warranty at any time during the first two years of ownership of the product. The purchase of an extended warranty extends to five years the warranty of any product offered with a standard two-year warranty. The total warranty period will not extend beyond five years. Any purchase of an extended warranty provides 24 x 7 customer support in addition to the warranty immediately upon purchase of the warranty extension.

Note *Clear-Com does not offer warranty extensions on UHF wireless intercom systems, or on any product with a 1-year or 90-day warranty.*

8.6 Service Contract

Clear-Com also offers service contracts that provide 24 x 7 telephone support, advance replacements, training, proactive maintenance, on-site visits, and no charge for repair or replacement of equipment. For more information, contact your authorized dealer, distributor, or sales representative.

8.7 Liability

THE FOREGOING WARRANTY IS CLEAR-COM'S SOLE AND EXCLUSIVE WARRANTY. THE IMPLIED WARRANTY OF MERCHANTABILITY AND FITNESS FOR A PARTICULAR PURPOSE AND ANY OTHER REQUIRED IMPLIED WARRANTY SHALL EXPIRE AT THE END OF THE WARRANTY PERIOD. THERE ARE NO OTHER WARRANTIES (INCLUDING WITHOUT LIMITATION WARRANTIES FOR CONSUMABLES AND OTHER SUPPLIES) OF ANY NATURE WHATSOEVER, WHETHER ARISING IN CONTRACT, TORT, NEGLIGENCE OF ANY DEGREE, STRICT LIABILITY OR OTHERWISE, WITH RESPECT TO THE PRODUCTS OR ANY PART THEREOF DELIVERED HEREUNDER, OR FOR ANY DAMAGES AND/OR LOSSES (INCLUDING LOSS OF USE, REVENUE, AND/OR PROFITS). SOME STATES DO NOT ALLOW THE EXCLUSION OR LIMITATION OF INCIDENTAL OR CONSEQUENTIAL DAMAGES OR THE LIMITATION ON HOW LONG AN IMPLIED WARRANTY LASTS, SO THE ABOVE LIMITATIONS MAY NOT APPLY TO YOU. IN ANY EVENT, TO THE MAXIMUM EXTENT PERMITTED UNDER APPLICABLE LAW, CLEAR-COM'S LIABILITY TO CUSTOMER HEREUNDER SHALL NOT UNDER ANY CIRCUMSTANCES EXCEED THE COST OF REPAIRING OR REPLACING ANY PART(S) FOUND TO BE DEFECTIVE WITHIN THE WARRANTY PERIOD AS AFORESAID.

This warranty does not cover any damage to a product resulting from cause other than part defect and malfunction. The Clear-Com warranty does not cover any defect, malfunction, or failure caused beyond the control of Clear-Com, including unreasonable or negligent operation, abuse, accident, failure to follow instructions in the manual, defective or improperly associated equipment, attempts at modification and repair not approved by Clear-Com, and shipping damage. Products with their serial numbers removed or defaced are not covered by this warranty.

This warranty does not include defects arising from installation (when not performed by Clear-Com), lightning, power outages and fluctuations, air conditioning failure, improper integration with non-approved components, defects or failures of customer furnished components resulting in damage to Clear-Com provided product.

This limited warranty is not transferable and cannot be enforced by anyone other than the original consumer purchaser.

This warranty gives you specific legal rights and you may have other rights which vary from country to country.