

FreeSpeak II™ Transceiver/antenna splitter

User Guide



Transceiver/antenna splitter

The FSII-SPL transceiver/antenna splitter is a device that connects multiple transceiver/antennas to an Eclipse matrix (E-Que-HX card) or FreeSpeak II Base Station. It has a matrix RJ-45 connector that carries the data between an E-Que card transceiver port and the splitter, and five antenna RJ-45 connectors to feed that information to and from up to five antennas. The splitter must be locally powered using the supplied external in-line universal power supply.

In addition, the FSII SPL provides fiber linking to a FSII-Base-II Base Station and another FSII-SPL unit. There are eight DIP switches to select the mode of operation, and to enable Local DECT synchronization and software updates.

You can mount the splitter on a flat surface or on a microphone stand using the screw points or stand connectors.

The FSII-SPL is compatible with both FSBP (FreeSpeak I) and FSII-BP (FreeSpeak II, 1.9 & 2.4) systems.

FSII-SPL front connector panel

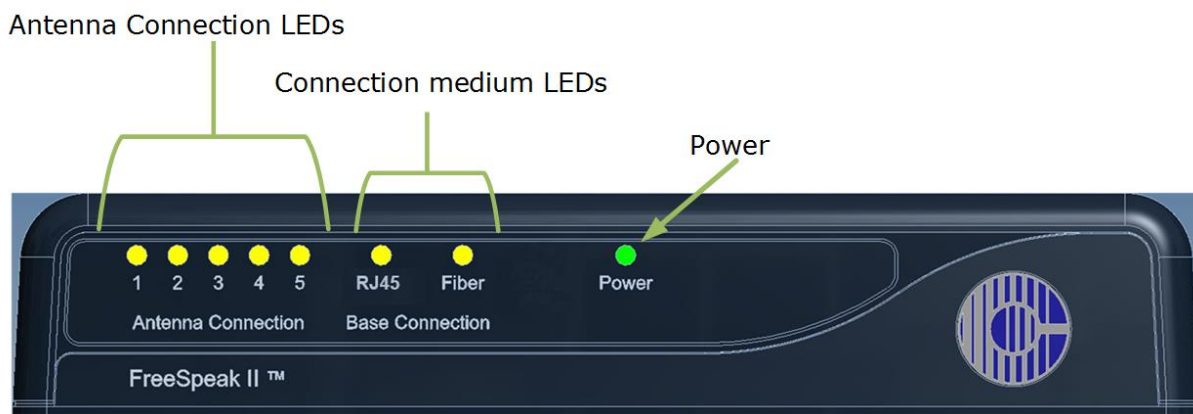

FSII-SPL Front Connector Panel

Antenna Connection LEDs

These yellow LEDs indicate that the splitter is receiving data from the antennas.

Base Connection LEDs

Connection to Base; RJ45 or fiber.+

- If the LEDs are steady on, DECT synchronization is being received from the Base Station/matrix.
- If the LEDs display a double flash, DECT synchronization is occurring locally.
- If the LEDs display a rapid pulse flash, there is no DECT synchronization (fault condition).

Power LED

This green LED indicates that the splitter is receiving power.

FSII SPL rear panel

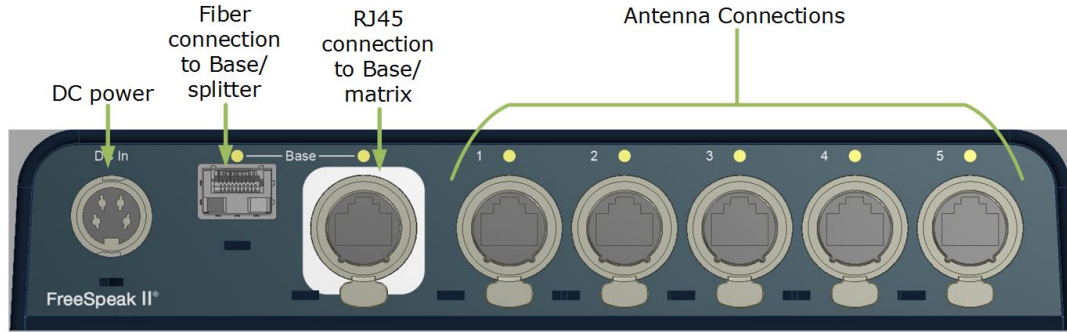

FSII-SPL Rear Connector Panel

DC IN power connector

This connector is used to locally power the splitter with the supplied universal power supply. Use of local power is required.

Fiber connection to Base Station or another FSII-SPL unit

This connector uses a Fiber Module (Part# HCI-SMFO or HCI-MMFO)

RJ45 connection to Base Station or matrix

One EtherCON RJ-45 connector

Antenna connectors

Five EtherCON RJ-45 connectors

Connecting and using a splitter

Connect the FSII-SPL base connector to matrix E-Que (RJ45 connection) or Base Station antenna port (can be RJ45 or fiber). Connect all antennas (up to 5) to splitter antenna ports. Also make sure that the both the power LED (green for 1.9 GHz, blue for 2.4 GHz) and the yellow data LED are lit on each antenna. If all are properly lit, then the connection has been successfully made and the coverage zones will be active and will support beltpacks. If the transceiver antennas are not lit, check the connections.

Note: Cable distances under 300m (985 feet), antennas can be powered by the splitter. Above 300m they must have direct/local power.

Make any necessary DIP switch settings (mode of operation, local DECT synchronization, firmware update).

DIP switch settings (default in **BOLD**)

1 to 5	Antenna ports 1 to 5 ON – Active OFF - Convert to Fiber
6	ON – Base Sync OFF – Local Sync
7	If 6 is switched to OFF ON – FreeSpeak II OFF – FreeSpeak I
8	ON – Update OFF – Normal operation

To access the DIP switches, remove the covering panel on the base of the splitter (two screws).

Note: When you change a DIP switch setting, you must re-power the unit for the change to have any effect.

Typical FSII-Base/FSII-splitter configurations using Clear-Com equipment

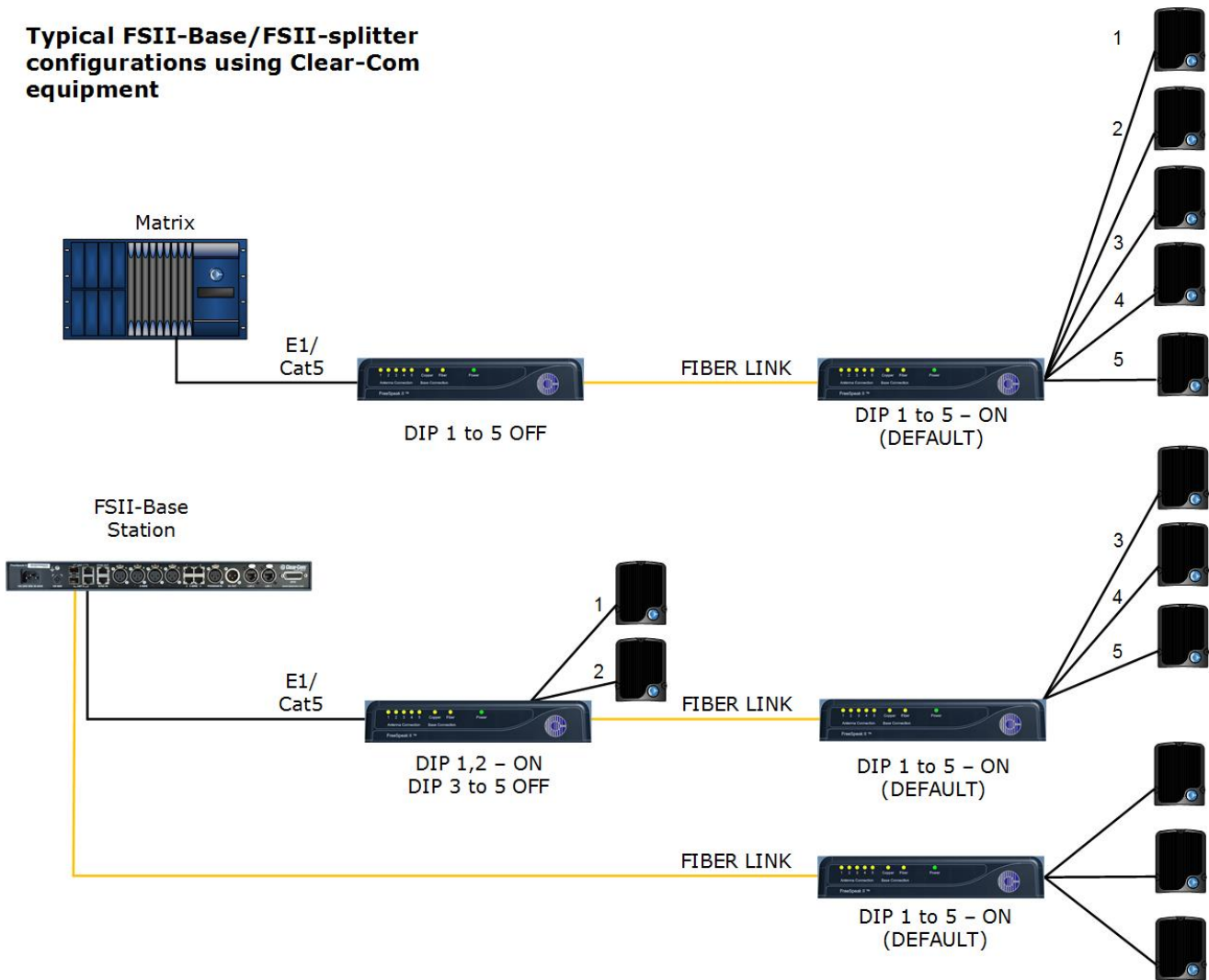

Typical system configuration using third party equipment

Note: In this configuration, there is no DECT Synchronization from the Base Station or matrix (DIP 6 – OFF). Only local DECT synchronization is possible.

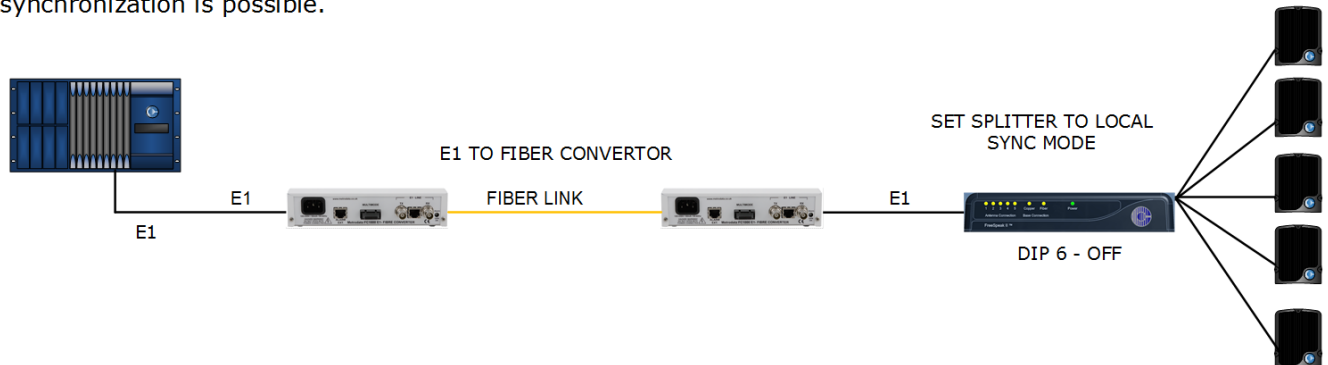

Copyright © 2016 HME Clear-Com Ltd. All rights reserved.