

User Guide

Arcadia R3 Central Station User Guide



Part Number: PUB-00021 Revision F

October 03, 2024

Document reference

Arcadia® Central Station User Guide

Part Number:PUB-00021 Revision F

Legal disclaimers

Copyright © 2024 HME Clear-Com Ltd

All rights reserved

Clear-Com and the Clear-Com logo are trademarks or registered trademarks of HM Electronics, Inc.

The software described in this document is furnished under a license agreement and may be used only in accordance with the terms of the agreement.

The product described in this document is distributed under licenses restricting its use, copying, distribution, and decompilation / reverse engineering. No part of this document may be reproduced in any form by any means without prior written authorization of Clear-Com, an HME Company.

Clear-Com Offices are located in California, USA; Cambridge, UK; Dubai, UAE; Montreal, Canada; and Beijing, China. Specific addresses and contact information can be found on Clear-Com's corporate website: www.clearcom.com

Clear-Com contacts

Americas and Asia-Pacific Headquarters

California, United States

Tel: +1 510 337 6600

Email: SalesSupportUS@clearcom.com

Europe, Middle East, and Africa Headquarters

Cambridge, United Kingdom

Tel: +44 1223 815000

Email: SalesSupportEMEA@clearcom.com

China Office

Beijing Representative Office

Beijing, P.R. China

Tel: +8610 59000198/59002608

Email: SalesSupportChina@Clearcom.com

Table of contents

| | |
|--|-----------|
| Table of contents | 3 |
| 1 Introduction | 8 |
| 1.1 Arcadia Central Station | 9 |
| 1.2 Connections | 14 |
| 2 System Examples | 15 |
| 2.1 Arcadia with Freespeak II Wireless - E1 | 16 |
| 2.2 Arcadia with FreeSpeak II Wireless-E1 and Splitter | 18 |
| 2.3 Arcadia with FreeSpeak Edge IP Transceivers | 20 |
| 2.4 Split Frequency Setup (5, 2.4 and 1.9 GHz System) | 22 |
| 2.5 Arcadia as HelixNet System Host | 23 |
| 2.6 Arcadia with FreeSpeak E1 and HelixNet | 23 |
| 2.7 Arcadia using LQ as Interface Expansion (I.V. Direct) | 24 |
| 3 Installing Arcadia Central Station | 25 |
| 3.1 Front Panel Connectors, Controls and Indicators | 26 |
| 3.2 Front Panel Touchscreens | 27 |
| 3.3 Rear Panel Connectors and Indicators | 30 |
| 3.4 System Powering | 31 |
| 3.5 Clear-Com Ethernet Cable Recommendations | 33 |
| 3.6 Stage Announce and Program Feed | 33 |
| 4 Configuring from the Front Panel | 35 |
| 4.1 Introduction to Configuring from the Front Panel | 36 |
| 4.2 Setting the Management IP Address | 36 |
| 4.3 Passwords, Addresses, Reset to Default, Save and Restore Configuration | 37 |
| 4.4 Front Panel Menus | 40 |
| 5 The Core Configuration Manager (CCM) | 45 |
| 5.1 CCM Introduction | 46 |
| 5.2 Changing the CCM Password | 49 |
| 5.3 Setting the Management IP from the CCM | 49 |
| 5.4 Saving and Restoring System Configuration | 50 |

| | |
|--|------------|
| 5.5 Resetting to Default | 51 |
| 5.6 Hardware Page Overview | 52 |
| 5.7 Host Page | 53 |
| 5.8 Configuring the Network | 54 |
| 5.9 Upgrading | 57 |
| 5.10 Setting Up the Wireless Beltpack System | 59 |
| 5.11 Resources Page | 61 |
| 5.12 Configuration Page Overview | 67 |
| 5.13 Channels and Groups | 68 |
| 5.14 Channels Page | 70 |
| Status | 71 |
| Name | 71 |
| Online | 71 |
| Talkers | 71 |
| 5.15 Groups Page | 76 |
| Status | 77 |
| Name | 77 |
| Online | 78 |
| Talkers | 78 |
| Adding Ports to a Group | 79 |
| Adding Roles to a Group | 79 |
| Configuring a Talk Key to the Group | 81 |
| 5.16 Roles Page | 83 |
| 5.17 Logic Page | 93 |
| 5.18 Status Page Overview | 97 |
| Transceiver details | 100 |
| Monitoring Beltpack Details | 101 |
| 6 Using FreeSpeak Wireless Intercom | 106 |
| 6.1 Overview of Transceivers | 107 |
| 6.2 Connecting Transceivers Over E1 | 107 |
| 6.3 Adding IP Transceivers | 112 |

| | |
|--|------------|
| 6.4 Network Setup for IP Transceivers | 113 |
| 6.5 Registering FreeSpeak Beltpacks | 117 |
| 6.6 FS Edge Transceivers | 120 |
| 7 Using HelixNet Wired Partyline Intercom | 123 |
| 7.1 Introduction | 124 |
| 7.2 HelixNet Connections - General Outline | 125 |
| 7.3 Connecting HelixNet User Stations to the network | 126 |
| 7.4 Pairing HelixNet User Stations to Arcadia | 126 |
| 7.5 Connecting User Stations via Digital Powerline Device | 129 |
| 7.6 Digital Powerline Device Statistics and Messages | 130 |
| 8 Using I.V. Direct | 132 |
| 8.1 What is I.V. Direct? | 133 |
| 8.2 I.V. Direct Configuration Overview | 134 |
| 8.3 Connecting I.V. Direct on your Network | 138 |
| 8.4 Configure I.V. Direct in the Arcadia CCM | 139 |
| 8.5 Using GPIO with I.V. Direct | 143 |
| 9 Using Dante Systems | 148 |
| 10 Using 2-Wire Systems | 152 |
| 10.1 Introduction to 2-Wire Systems | 153 |
| 10.2 2-Wire Port Compatibility | 156 |
| 11 Using 4-Wire Systems | 157 |
| 11.1 Connecting 4-Wire | 158 |
| 11.2 Port Function (4-Wire Pinout) | 162 |
| 11.3 Connecting 4-Wire Clear-Com to Clear-Com | 163 |
| 11.4 Setting Port Function (Pinout) on a 4-Wire Connection | 164 |
| 12 Upgrading Firmware | 165 |
| 12.1 Introduction | 166 |
| 12.2 Upgrading using the CCM | 166 |
| 12.3 Upgrading using a USB Stick | 166 |
| 12.4 HelixNet Upgrade | 167 |
| 13 Licensing | 168 |

| | |
|--|------------|
| 13.1 Licensed Ports | 169 |
| 13.2 Online Activation of Additional Licenses (Recommended) | 169 |
| 13.3 Offline Activation of Additional Licenses | 171 |
| 14 Security | 175 |
| 14.1 Warning | 176 |
| 14.2 Secure HyperText Transfer Protocol (HTTPS) | 176 |
| 14.3 Using HTTPS | 176 |
| 14.4 The Force HTTPS Feature | 176 |
| 14.5 Forcing HTTPS | 177 |
| 14.6 Using Security Certificates | 179 |
| 15 Appendix A: Pinouts | 180 |
| 15.1 GPIO pinouts | 180 |
| 15.2 2-Wire Pinouts | 182 |
| 15.3 4-Wire Pinouts | 183 |
| 15.4 DECT Sync | 183 |
| 16 Appendix B: Specifications | 184 |
| 16.1 Arcadia Central Station | 185 |
| 16.2 Capacity | 189 |
| 16.3 Network Specifications | 190 |
| 17 Appendix C: Spare Parts | 192 |
| 18 Appendix D: Front Panel Menu Reference Tables | 193 |
| 18.1 Audio Settings | 194 |
| 18.2 Host Settings | 194 |
| 18.3 2 W Audio (A/B) (C/D) | 195 |
| 18.4 Discovery | 195 |
| 18.5 Transceiver | 196 |
| 18.6 Networking | 197 |
| 18.7 Administration | 198 |
| 19 Appendix E: Regulatory Compliance (Regulatory Model: 1410) | 201 |
| 19.1 FCC Notice | 201 |
| 19.2 FCC/IC/EC RF Exposure Warning | 202 |

19.3 Industry Canada Compliance Statement202

19.4 Korean Notice 202

19.5 European Union (CE mark) 203

19.6 United Kingdom (UKCA Mark)203

19.7 Electrical and Electronic Equipment (WEEE) Waste204

1 Introduction

This chapter provides an overview of the Arcadia Central Station. It contains the following sections:

| | |
|-----------------------------------|----|
| 1.1 Arcadia Central Station | 9 |
| 1.2 Connections | 14 |

1.1 Arcadia Central Station

The Arcadia® Central Station provides a scalable IP networked intercom system. It has a compact 1RU form and can be configured either from the browser-based Core Configuration Manager (CCM) or from the front panel menu system. The Arcadia intercom system supports both wireless (FreeSpeak) and wired (HelixNet) user stations, in a variety of form factors, frequencies and connectivity types.

As an intercom user station, Arcadia provides 4 keysets with high resolution touch-screen control. Keysets are assignable to any channel, group, beltpack, program audio or stage announce. The user station has a headset connection, a gooseneck mic connector and a loudspeaker, in addition to All Call, Stage Announce and Remote Mic Kill buttons.

Arcadia interfaces with a variety of audio and intercom systems; Dante, 4-wire line-level audio, 2-wire partyline connections to existing analog intercom systems. GPIO connections provide inputs and relay outputs for system control and interfacing, programmable in Arcadia's logic configurator (navigate to:**CCM>Configuration>Logic**).

1.1.1 Features

- Combined FreeSpeak wireless and HelixNet wired intercom
- I.V. Direct for intercom expansion and system bridging locally or globally
- Dante network and analog audio interfacing
- 2-wire partyline intercom
- GPIO control and interfacing
- Plug-and-go with central discovery and pairing
- Intuitive CCM browser configuration
- Front panel touch screen intercom user station and configuration
- Scalable capacity licensing

1.1.2 Maximum System Capacity

• Wireless intercom



• Wired intercom



- **Dante ports up to 64** (subject to licensed ports)
- **I.V. direct ports up to 16** (subject to licensed ports)
- **4-wire ports x 8** (Port 8 = program feed and stage announce)
- **2-wire ports x 4** (Clear-Com and RTS)

FreeSpeak wireless intercom

- 10 E1 transceivers (1.9, 2.4 GHz)
- 32 IP transceivers (1.9 GHz, 5 GHz)
- 64 beltpacks* (1.9, 2.4, 5 GHz)

HelixNet wired partyline intercom

- 24 HelixNet enabled channels
- 128 HelixNet user stations (beltpacks, remote station, speaker station)
- 24 HelixNet Powerline devices

Dante audio network interfaces

- 64 Dante ports*

I.V. Direct ports

- 16 I.V. Direct ports*

* **Subject to licensed port capacity**

Hardwired ports

- 8 four-wire connections
 - Port 8 is dedicated to program feed and stage announce audio
- 4 two-wire connections
 - Clear-Com or RTS

System limits

- 100 channels
- 100 groups
- 200 roles

1.1.3 Licensed Ports – Scalable Port Capacity



1 wireless beltpack consumes 1 licensed port



1 channel consumes 1 licensed port

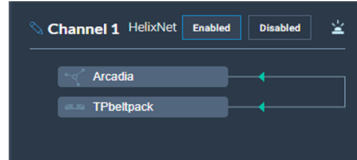

1 HelixNet enabled channel consumes 1 licensed port

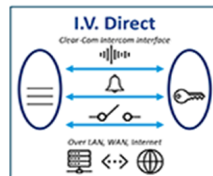

1 I.V. Direct port consumes 1 licensed port

Up to 168 licensed ports. Licensed ports are consumed by:

- One FreeSpeak beltpack (1 port)
- One HelixNet enabled channel (1 port)
- One Dante channel (1 port)
- I.V. Direct port (1 port)

How many licensed ports do I need? Use the *Arcadia Online Licensed Port Calculator* available from the [Arcadia Knowledge Center](#).

Arcadia is ordered from Clear-Com with Licensed Port capacity:

| Part number | Licensed ports |
|--|--------------------|
| ARCADIA-X4-16P | 16 Licensed ports |
| ARCADIA-X4-32P | 32 Licensed ports |
| ARCADIA-X4-48P | 48 Licensed ports |
| ARCADIA-X4-64P | 64 Licensed ports |
| ARCADIA-X4-80P | 80 Licensed ports |
| ARCADIA-X4-96P | 96 Licensed ports |
| ARCADIA-X4-112P | 112 Licensed ports |
| ARCADIA-X4-128P | 128 Licensed ports |
| ARCADIA-X4-144P | 144 Licensed ports |
| ARCADIA-X4-160P | 160 Licensed ports |
| ARCADIA-X4-168P | 168 Licensed ports |
| Note: Arcadia-X5-XXX P is also available, with a five-pin headset connector | |

Arcadia Licensed Port capacity can be upgdaded in the field in increments of 8 or 16 ports available from Clear-Com.

1.1.4 More Information

For more information, refer to the [Arcadia Knowledge Center](#).



www.clearcom.com/Download-Center/Knowledge-Centers/Arcadia-Knowledge-Center

1.2 Connections

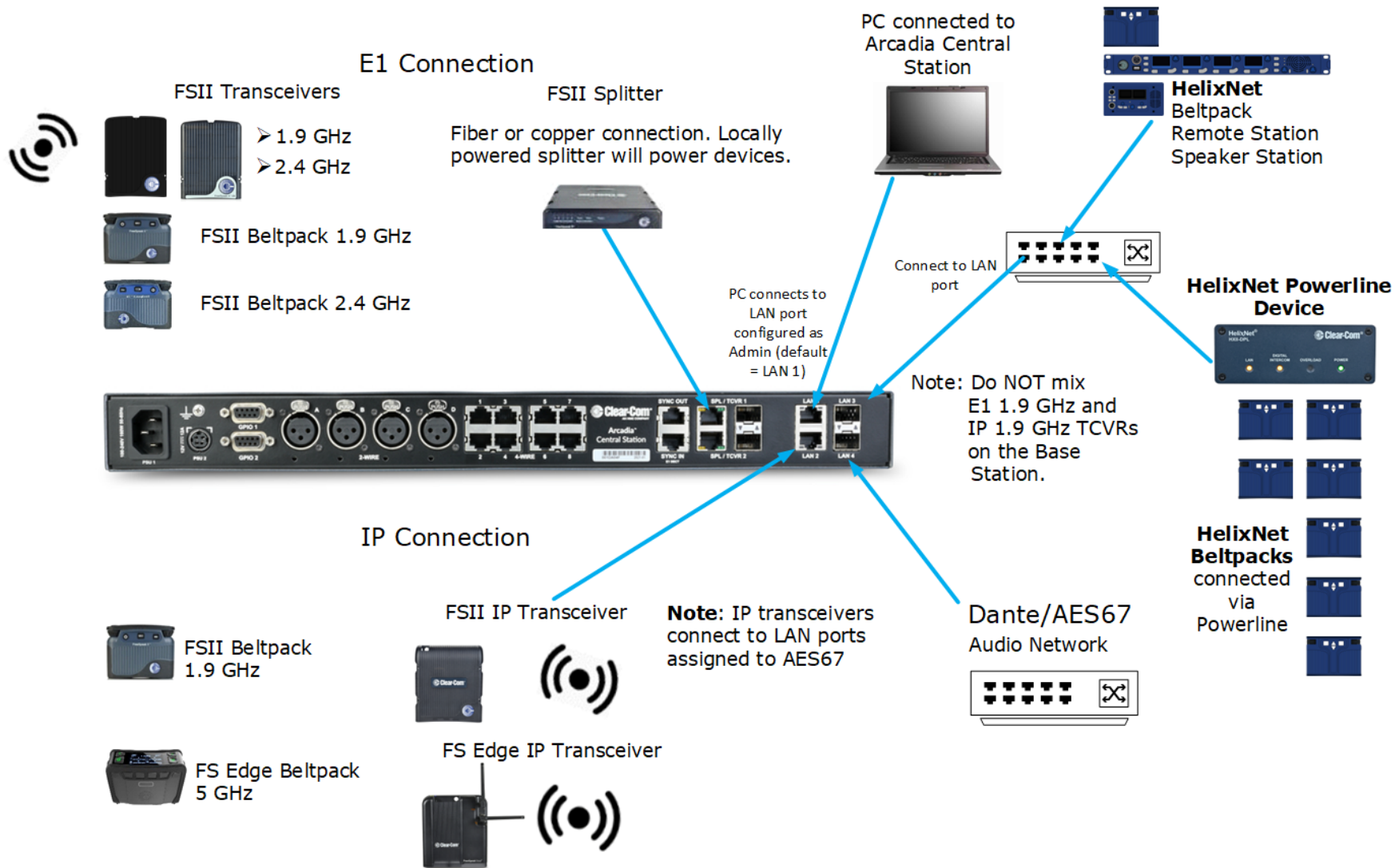

2 System Examples

This chapter contains examples of typical applications. It contains the following sections:

- 2.1 Arcadia with Freespeak II Wireless - E1 16
- 2.2 Arcadia with FreeSpeak II Wireless-E1 and Splitter 18
- 2.3 Arcadia with FreeSpeak Edge IP Transceivers 20
- 2.4 Split Frequency Setup (5, 2.4 and 1.9 GHz System) 22
- 2.5 Arcadia as HelixNet System Host 23
- 2.6 Arcadia with FreeSpeak E1 and HelixNet 23
- 2.7 Arcadia using LQ as Interface Expansion (I.V. Direct) 24

2.1 Arcadia with Freespeak II Wireless - E1

The FreeSpeak II E1 transceivers use an E1 connection (telecommunications standard) directly to the Arcadia. The Core Configuration Manager (CCM) is the easiest way to configure your system, but this setup can be configured with minimal use of the CCM if you work with the default role setup. Using the default setup, all devices have talk and forced listen keys to Channel 1 and Channel 2 and can engage call signals to those channels.

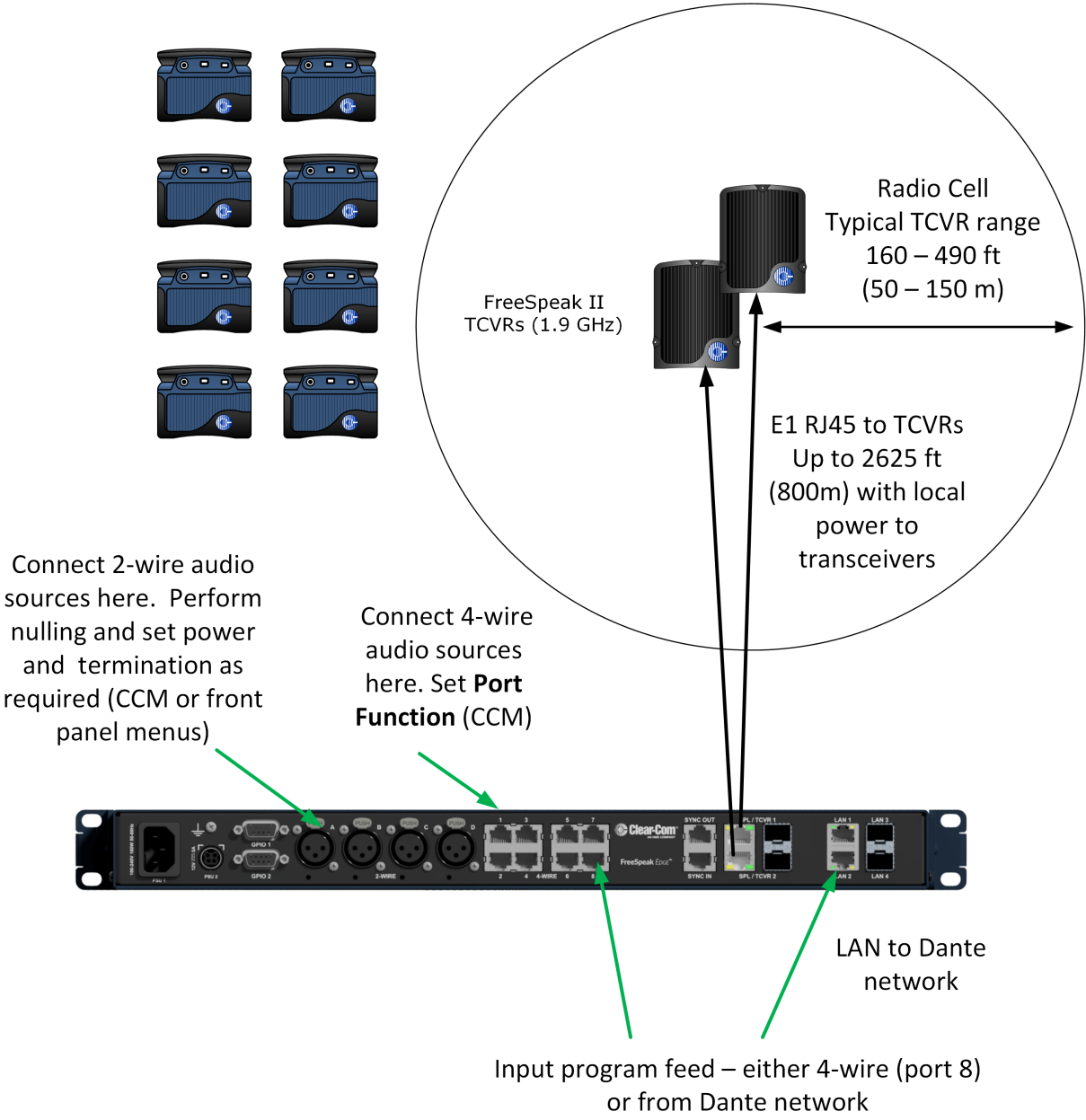

2.1.1 Outline of General Setup and Configuration

- For E1 setup, see [Connecting Transceivers Over E1 on page 107](#).
- To access the CCM, see: [The Core Configuration Manager \(CCM\) on page 45](#).
- To register beltpacks, see [Registering FreeSpeak Beltpacks on page 117](#).
- To set Port Function, see [Setting Port Function \(Pinout\) on a 4-Wire Connection on page 164](#).
- To perform null and set power, see [Using 2-Wire Systems on page 152](#).
- To connect Program Feed, see [Stage Announce and Program Feed on page 33](#)

2.2 Arcadia with FreeSpeak II Wireless-E1 and Splitter

This setup includes two splitters, both connected via shielded Cat 5e cable using E1 connectivity. Four channels are configured in the CCM: Channel 1=ALL, Channel 2=Lighting, Channel 3=Sound, Channel 4=FoH. 16 roles are configured for the beltpacks.

There are four connectors on the rear of the device for splitters. Two splitters can be connected using Cat 5e cable or Fiber or a combination of Cat 5e and Fiber.

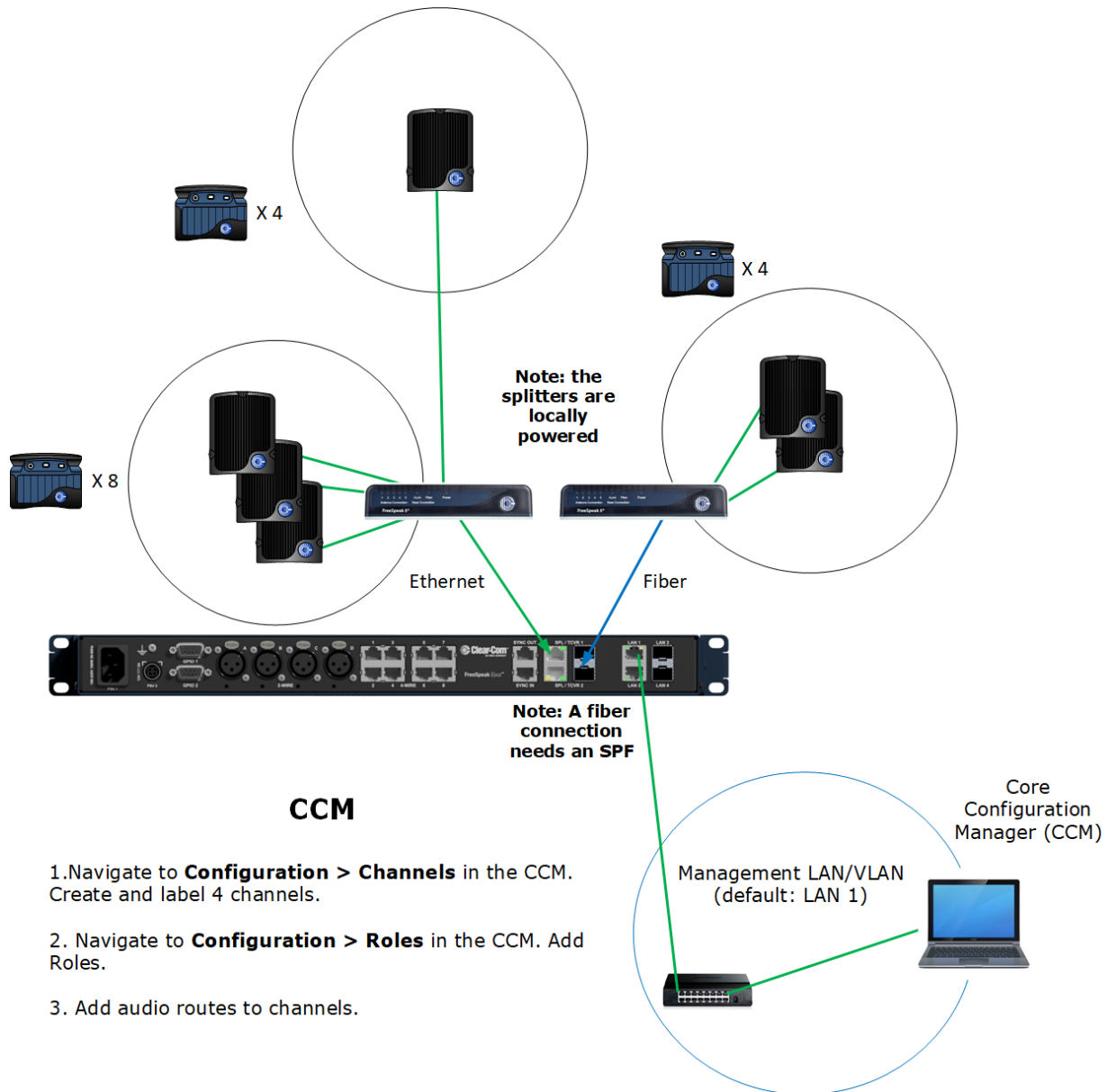

2.2.1 Outline of General Setup and Configuration

- For E1 setup, see [Connecting Transceivers Over E1 on page 107](#).
- To set the splitter DIP switches, see the FSII Splitter Quick Start Guide (FSII SPL-QSG) in the Clear-Com FreeSpeak II Knowledge Center on the Clear-Com website:
[Clear-Com FreeSpeak II Knowledge Center](#)
- To access the CCM, see [The Core Configuration Manager \(CCM\) on page 45](#).
- To register beltacks, see [Registering FreeSpeak Beltacks on page 117](#).
- To set port settings for 2-wire sources, see [Using 2-Wire Systems on page 152](#).
- To set port settings for 4-wire sources, see [Using 4-Wire Systems on page 157](#).
- To connect program and stage announce, see [Stage Announce and Program Feed on page 33](#).
- To configure channels, see [Status on page 71](#).
- To configure Roles, see [Managing Roles on page 84](#).

2.3 Arcadia with FreeSpeak Edge IP Transceivers

This setup has a total of 6 FS Edge transceivers with 16 beltpacks. The transceivers are connected via a network that is configured for AES67 traffic. These are configured using the CCM. There are four 2-wire partylines and a Dante network.

Note: *The Dante network must be on a different VLAN or network from the IP transceivers.*

Note: *The AES67 network must be set up correctly for the IP transceivers in order to meet the needs of Clear-Com IP transceivers for high levels of PTP accuracy.*

See the *AoIP Network Recommendations* guide, available from the [Clear-Com FSII Knowledge Center](#).

FS Edge 5 GHz
beltpacks x 16

Register at the
Base or in the
CCM



Note: This setup assumes a dedicated network switch for the Edge Base, transceivers and CCM.

Note: You cannot configure the IP transceiver network (AES67) and Dante to the same network port.

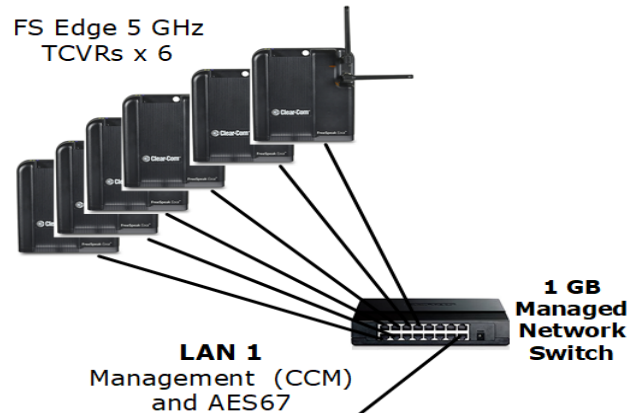

1. You will need to use the **Discovery** feature in the CCM to add IP transceivers to your system.

2. You will need to configure Dante feeds in the Audinate Dante Controller before these can be added to channels in the CCM.

Key
Cat5e/6a Shielded
Ethernet cable
23/24 AWG
(max 100m)

2.3.1 Outline of General Setup and Configuration

- For network setup, see [Network Setup for IP Transceivers on page 113](#).
- To access the CCM, see [The Core Configuration Manager \(CCM\) on page 45](#).
- To add IP transceivers to your system, see [Using FreeSpeak Wireless Intercom on page 106](#).
- For information on the connection process for IP transceivers, see the Quick Start Guides (QSGs) for FS Edge IP transceivers available from the [FreeSpeak Edge Knowledge Center](#).
- For information about connecting to 2-wire systems, see: [Using 2-Wire Systems on page 152](#).
- For information about connecting to Dante, see: [Using Dante Systems on page 148](#).
- For information about Channels, see [Status on page 71](#).
- For information about Roles, see [Managing Roles on page 84](#).

2.4 Split Frequency Setup (5, 2.4 and 1.9 GHz System)

This setup has:

- E1 FS II transceivers (1.9) with 5 beltpacks
- E1 FS II transceivers (2.4) with 4 beltpacks
- FS Edge IP transceivers (5) with 10 beltpacks
- FS II IP transceivers (1.9) with 10 beltpacks.

The E1 Transceivers will automatically connect to the Arcadia once powered, but the Edge IP transceivers require additional configuration in the CCM and must be connected to a network that is configured for AES67 traffic.

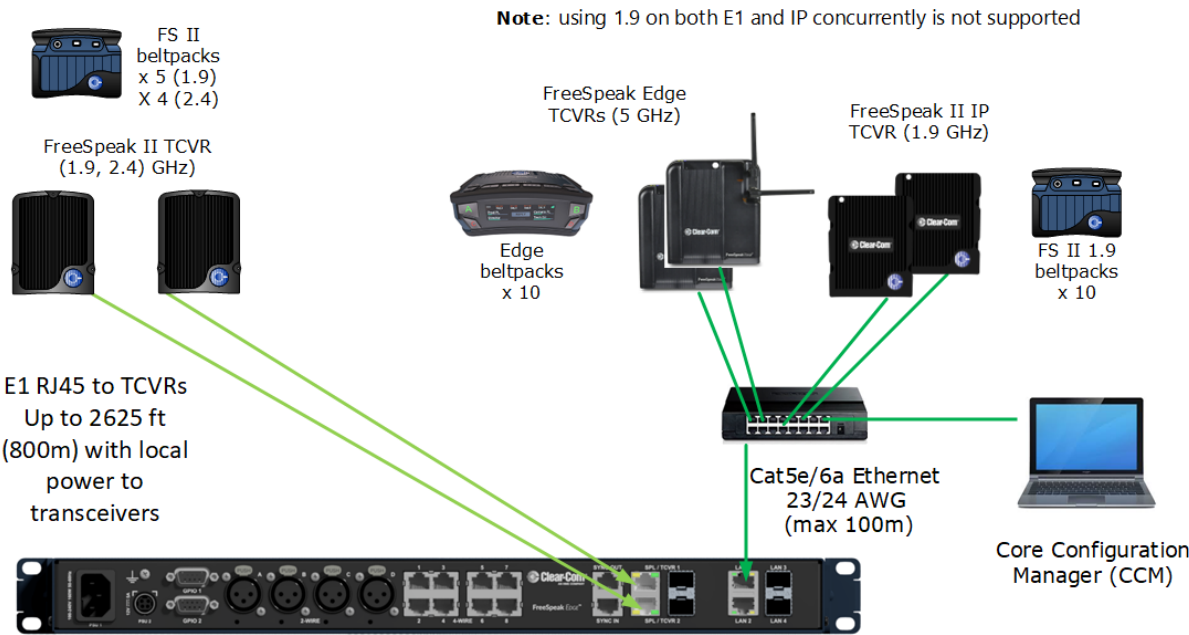

CCM Configuration

2 x Channels: Cameras, Lighting

16 x Roles: Director, Stage Manager, Runners, Maintenance, Lighting, Sound

Note: you can create roles that can be used by FS Edge and/or FS II beltpacks (the role can only be used by 1 beltpack at any given time).

2.5 Arcadia as HelixNet System Host

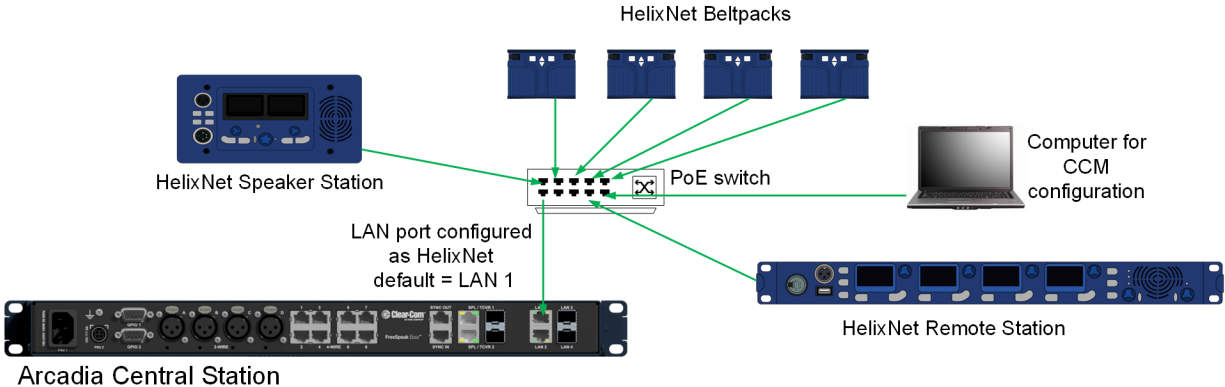

Up to:

- 24 HelixNet enabled channels (subject to licensed ports)
- 128 HelixNet user stations

For information on how to configure this set up see [Using HelixNet Wired Partyline Intercom on page 123](#).

2.6 Arcadia with FreeSpeak E1 and HelixNet

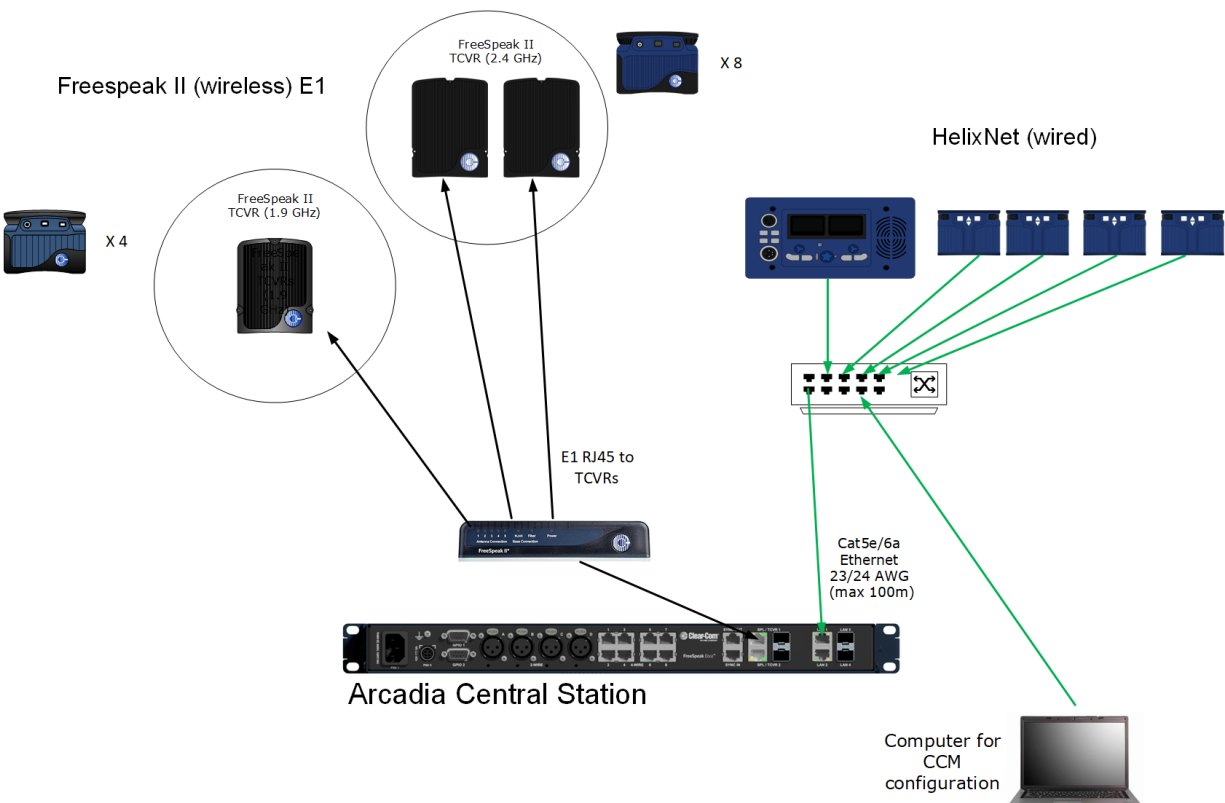

To configure FreeSpeak with E1 see [Connecting Transceivers Over E1 on page 107](#)

To configure HelixNet in Arcadia see [Using HelixNet Wired Partyline Intercom on page 123](#)

2.7 Arcadia using LQ as Interface Expansion (I.V. Direct)

I.V. direct connections enable various workflows:

- Interface expansion via LQ
 - 2-Wire and 4-Wire
 - 2-way radio
 - SIP
 - Agent-IC and Station -IC
 - LAN/WAN/Internet

Remote Partyline (Encore) to Arcadia Central



Radio to Arcadia Central

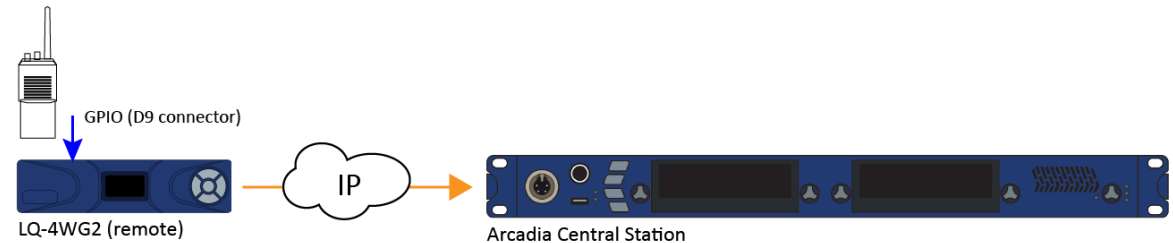

Agent-IC to Arcadia Central

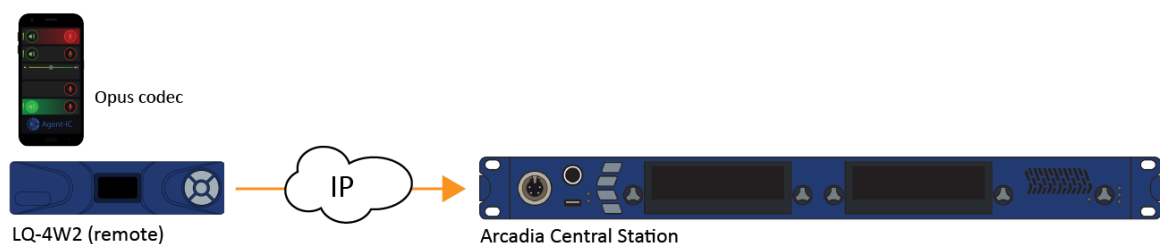

For configuration examples see [Using I.V. Direct on page 132](#)

3 Installing Arcadia Central Station

This chapter describes the front and rear panels, power supplies and cabling recommendations. It also describes network setup and illustrates example applications. It contains the following sections:

- 3.1 Front Panel Connectors, Controls and Indicators 26
- 3.2 Front Panel Touchscreens 27
- 3.3 Rear Panel Connectors and Indicators 30
- 3.4 System Powering 31
- 3.5 Clear-Com Ethernet Cable Recommendations 33
- 3.6 Stage Announce and Program Feed 33

3.1 Front Panel Connectors, Controls and Indicators

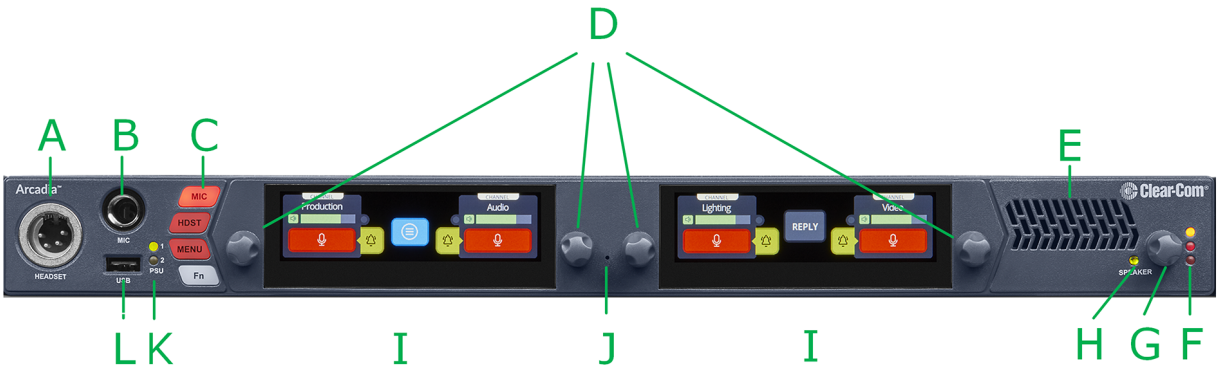

The Arcadia front panel connectors, controls and indicators are listed below.

| Item | Description |
|------|---|
| A | Headset connector (4-pin or 5-pin XLR). |
| B | Gooseneck mic socket (1/4-inch jack) |
| C | <p>Mic: Toggles microphone audio on and off to the keysets on the unit (similar to the Talk button). The Mic button overrides the effect of a latched talk on a keyset.</p> <p>HDST: When a headset is connected, this button switches audio between the headset microphone and the gooseneck microphone.</p> <p>Menu: Press to enter menu mode. Press again to exit, or allow menu mode to time out.</p> <p>Fn: Function button. For future use.</p> |
| D | Rotary Encoders. Use these to control channel volume or to navigate through the menu system. |
| E | Loudspeaker |
| F | <p>Main Volume Level LEDs:</p> <ul style="list-style-type: none"> • Red - high volume level • Amber - medium volume level • Green - low volume level |
| G | Main Volume Control. This controls the listen levels for both the speaker and the headset. Pressing this control will mute/unmute the speaker audio output. |

| Item | Description |
|------|---|
| H | Speaker active LED: lights green when the speaker is active. Arcadia channel audio is heard here. The speaker is automatically active when there is no headset plugged into the Arcadia. |
| I | Color touchscreen displays |
| J | Pin reset. Pin reset causes the device to power cycle (reboot) |
| K | Power input status indicators |
| L | USB A connector. Use to: <ul style="list-style-type: none">• Register beltpacks• Upgrade the Arcadia• Save/Restore system settings• Obtain detailed logs for diagnostic purposes |

3.2 Front Panel Touchscreens

The Arcadia has two intercom control touchscreens, available when the front panel screens are not in menu mode. Each touchscreen provides access to two keys which can be configured for channels, groups or point to point communications channels.

3.2.1 Left Intercom Touchscreen

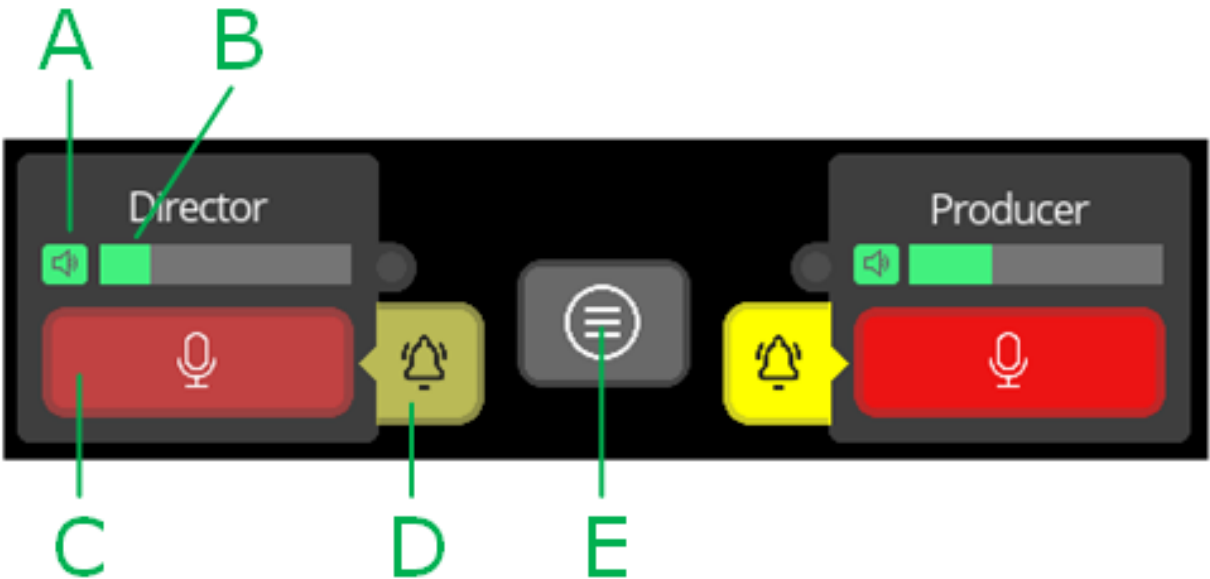

| Item | Description |
|------|--|
| A | Listen activation indicator. |
| B | Volume level indicator. Control the volume with the rotary controller next to the channel/audio source. |
| C | Talk button. |
| D | Call button. Use this to send a call signal. |
| E | Menu button. Touch to see: <ul style="list-style-type: none"> • Stage Announce • All talk • Remote mic kill (RMK) |

3.2.2 Right Intercom Touchscreen

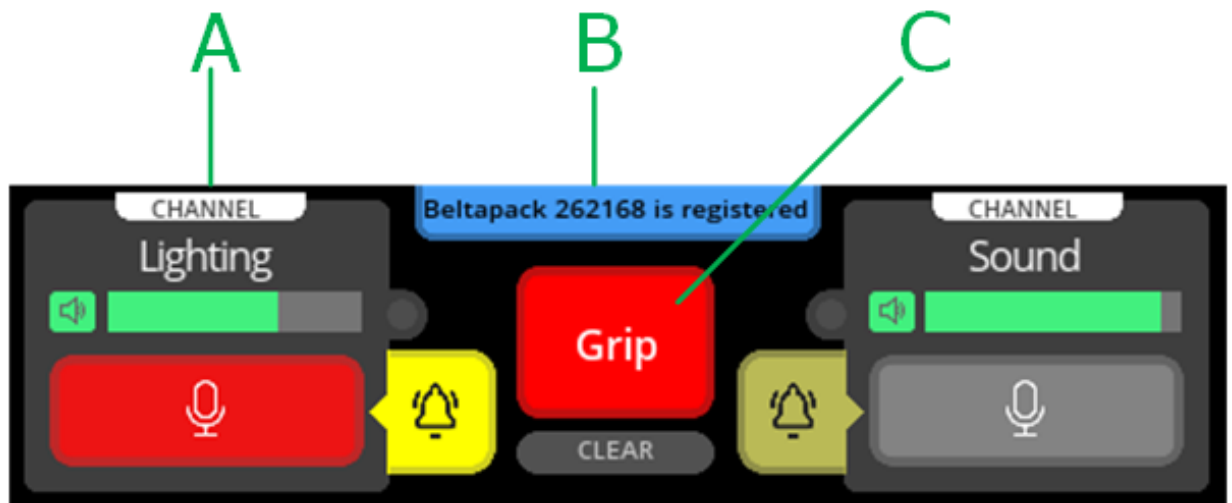

| Item | Description |
|------|--|
| A | Channel indication. Channels are set in the CCM: Configuration>Roles>Arcadia Central Station . Audio routes can be point-to-point or channels. |
| B | Notification bar <ul style="list-style-type: none">• Beltpack registration• Progress of upgrades• Support information gathering• Resoration of configuration progress |
| C | Reply button. Use CLEAR to clear the currently visible entry (does not clear the entire key stack). |

3.3 Rear Panel Connectors and Indicators

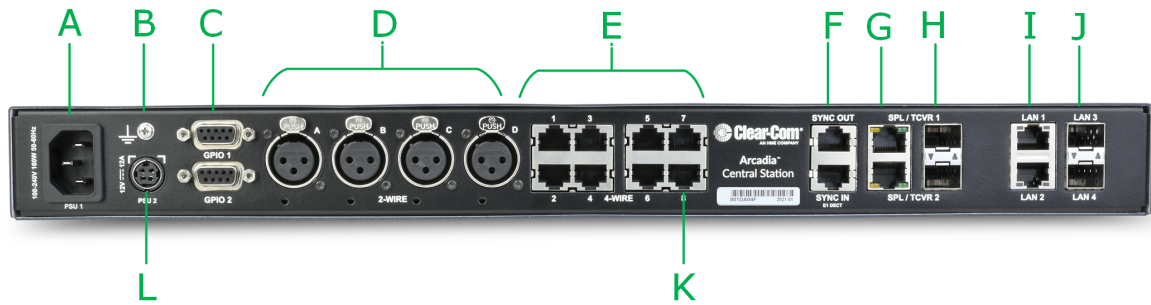

The Arcadia rear connectors and indicators are listed below.

| Item | Description |
|------|---|
| A | Internal power connector. Mains power lead with internal power supply. |
| B | Grounding screw. |
| C | General Purpose Input/Output connectors x2 (DB-9F). <ul style="list-style-type: none"> GPIO 1 hosts GPI1 and GPO1 & 2 GPIO 2 hosts GPI2 and GPO 3 & 4. |
| D | XLR 2-wire Partyline connectors (analog) |
| E | RJ45 4-wire audio and data connectors. Port 8 is dedicated to Program Feed (PGM) and Stage Announce (SA), to be used with the split RJ45 cable connector that is supplied with the Arcadia. |
| F | Dect Sync RJ45 connectors, IN, OUT. |
| G | E1 RJ45 connectors to FreeSpeak II splitter/transceiver. Do not connect IP transceivers here. |
| H | SFP cage for E1 fiber connection to splitter/transceiver. Either single-mode or multi-mode fiber modules. Modules must match existing cabling. Do not connect IP transceivers here. |
| I | RJ45 LAN connectors. Assignable to Management (HelixNet/I.V. Direct), Dante primary, Dante secondary, AES67 for FreeSpeak IP transceivers. |
| J | SFP cage for optional fiber or RJ45 LAN modules. Assignable to Management (HelixNet/I.V. Direct), Dante primary, Dante secondary, AES67 for FreeSpeak IP transceivers. |

| Item | Description |
|------|---|
| K | Program Audio input and Stage Announce output. Use with supplied RJ45 to XLR adaptor cable.. |
| L | External power supply connector. CAUTION: Before using, see System Powering on page 31 . |

3.4 System Powering

Arcadia features dual power inputs:

- Mains power connector (IEC) internal power supply
- DC connector. External AC/DC power adapter (12V DC, 12A)

Both power inputs can be connected in parallel for redundancy.

3.4.1 Using the External DC Power Connector

CAUTION: YOU MUST CONNECT THE EXTERNAL DC POWER SUPPLY IN THE ORDER DESCRIBED AND ILLUSTRATED BELOW:

1. Connect the external power supply 12V cable connector (A) to the rear chassis 12V input connector of the Station.

Note: When connecting the power cable, be sure to push until the connector locks into the device.

Station (rear, left-side)

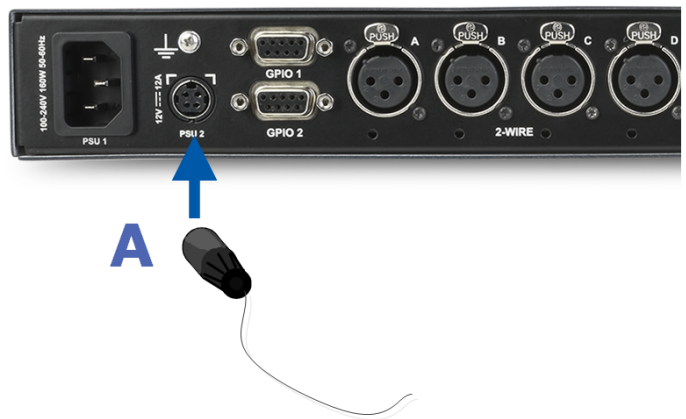

2. Connect External Power Supply mains cord (B) to the AC input source.

Mains connector

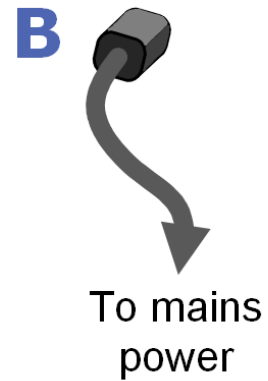

3.5 Clear-Com Ethernet Cable Recommendations

| Cable recommendations | |
|--|--|
| Category (Cat) | <p>Higher Cat numbers will support a higher bandwidth. Therefore, by using a higher Cat number you are future proofing your system to some extent. Example:</p> <ul style="list-style-type: none"> • Cat 5e : up to 1 GB • Cat 6: up to 10 GB <p>Use Cat 5e or higher.</p> |
| American Wire Gauge (AWG) | <p>The lower the AWG number, the less temperature rise there will be in the cable when using PoE. This is particularly important for bundles. Local building regulations may rule out the use of 26 AWG or higher, depending on the installation. Check with your local building regulations. Use AWG 24 or lower.</p> |
| Shielded Twisted Pair (STP) or Foiled Twisted Pair (FTP) | <p>Using shielded cable means less problems with interference from other sources. This means that your installation will be more robust if you use shielded cables.</p> |

Note: Overall recommendation: Use Cat 6a, 23 AWG STP cable.

3.6 Stage Announce and Program Feed



Your Arcadia Central Station is supplied with an RJ45 connector that uses a splitter cable to split into two XLR connectors. If you wish to use an external Stage Announce (**SA**) and Program audio (**PGM**), you must connect this to the RJ45 port labeled **SA/PGM** (port 8) on the rear of your device, and connect your input (**PGM**) and output (**SA**) to these connectors.

- Stage announce (audio out): Male XLR
- Program feed (audio in): Female XLR

Navigate to **Configuration > Channels** in the CCM and click the add button  next to the PGM and SA ports to put them into channels as required. These audio resources can be routed with **Channels, Groups, Roles** and **Logic** events (GPIOs).

Note: *These resource are unidirectional (simplex, not duplex).*

4 Configuring from the Front Panel

This chapter describes how to configure the Arcadia Central Station from the front panel. It contains the following sections:

- 4.1 Introduction to Configuring from the Front Panel 36
- 4.2 Setting the Management IP Address 36
- 4.3 Passwords, Addresses, Reset to Default, Save and Restore Configuration 37
- 4.4 Front Panel Menus 40

4.1 Introduction to Configuring from the Front Panel

Some common tasks you might perform from the front panel menus are:

- See/configure the Arcadia IP address
- See the default CCM password
- Null your 2-wire audio ports
- Reset the Arcadia to factory settings
- Reset the CCM password

To enter the Arcadia menu system, press the **Menu** button on the front panel. Navigate through the hierarchical menu using the rotary controllers. To select or commit a menu item, press the rotary encoder next to it.

To exit the menu system, press the Menu button again, or leave the device to time-out of menu mode (20 seconds).

4.2 Setting the Management IP Address

By default your Arcadia works with DHCP. However, you can set a static IP address for any of the station Ethernet ports (with the exception of Dante audio that is defined by the Audinate Dante Controller).

The Management IP address can be set:

- From the Arcadia front panel menus
- From the CCM

4.2.1 Setting the Management IP Address from the Front Panel Menus

1. Press the **MENU** button.
2. Using the far left rotary controller, navigate to **Networking**.
3. Select **Management**.
4. Navigate to **DHCP** and select **DISABLED**. Push to select menu item.
5. A numerical touchscreen keypad appears in the screen.
6. Using the touchscreen, press **Clr** to clear the IP address field.
7. Enter the new IP address using the touchscreen.
8. Press **OK**.
9. Edit the subnet if required.
10. Press **OK**.
11. The Management IP address has been changed.

For more information, see [LAN Configuration Rules on page 54](#).

4.3 Passwords, Addresses, Reset to Default, Save and Restore Configuration

You can find the Arcadia IP address, manage the CCM password and reset to default settings.

4.3.1 Find the Arcadia IP Address

1. Press the **Menu** button on the front of the Arcadia.
2. Navigate to **Networking > Management > IP Address** using the rotary controllers.
3. You will see the device IP address.



4.3.2 Find the default password for the CCM

1. Press the **Menu** button on the front of the Arcadia.
2. Navigate to **Administration > CCM Access > Default Password** using the rotary controllers.
3. You will see the default password in the right hand menu screen.

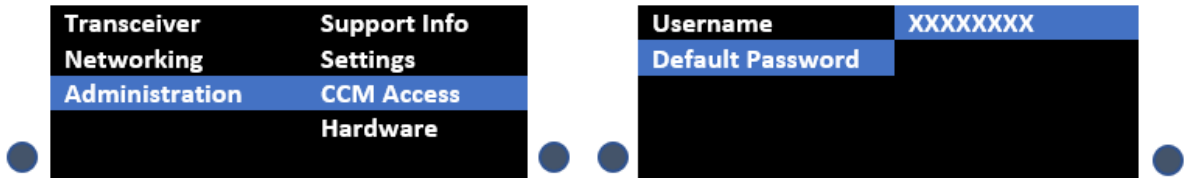

4.3.3 Reset the device to default settings

1. Press the **Menu** button on the front of the Arcadia.
2. Navigate to **Administration > Reset > Reset To Default > Reset Base**.
3. The Arcadia will reset to factory settings.

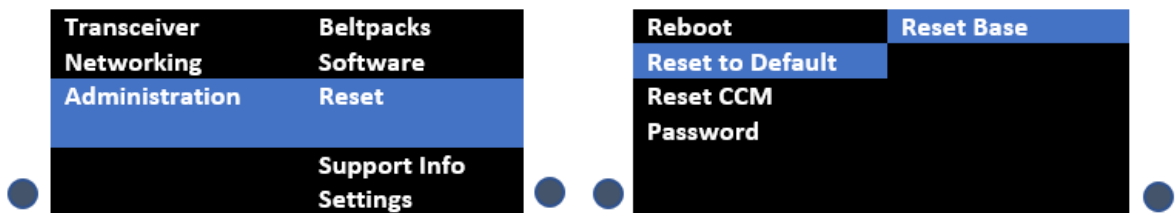

Note: When you use a pin reset on front the front of the Arcadia the device power cycles.

Note: When resetting the Arcadia to default settings using the front panel menu system, all the system configuration details, including network settings are reset. The management IP of the Arcadia will change.

Note: When you reset the Arcadia to default settings, you must **Add** the IP transceivers to the system again. See [Adding IP Transceivers on page 112](#).

Note: HelixNet endpoints will all revert to default configuration.

4.3.4 Reset the CCM password

1. Press the **Menu** button on the front of the Arcadia.
2. Using the right hand rotary controller select **Administration > Reset > Reset CCM Pass.**
3. Press the right hand rotary controller.
4. The password will reset to its default setting.

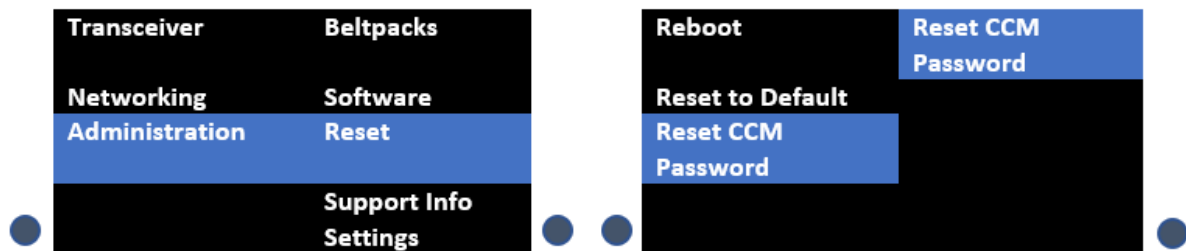

4.3.5 Save/Restore System Setup

1. Insert a USB drive into the USB connector on the front of the Arcadia.
2. Press the **Menu** button.
3. Using the rotary controllers, navigate to **Administration > Settings > Save.**
4. Push the 4th rotary controller. System settings are saved to the USB drive. The progress of this Save is shown in the notification bar on the front panel.
5. The file is saved in a folder called **/backupConfig/** in the USB. The file name format is **hostNameDateTime.cca.**

Note: *When you restore system settings in the CCM, Network and OTA System ID settings are optional. When you restore system settings from the front panel all settings are recalled which may cause system conflicts.*

4.4 Front Panel Menus

The front panel menu options are listed below.

4.4.1 Audio Settings

Headset

- **Headset Limit.** This allows the user to set the headset limiter for the front panel headset.
 - -12 dB to +8 dB/ OFF
- **HS Mic Type**
 - Dynamic (default)
 - Electret
- **Sidetone Gain**
 - -12 dB to +8 dB (-12 dB default)
- **Sidetone Control**
 - Tracking (default)
 - Non-Tracking
 - Disabled

Gooseneck

- Electret
- Dynamic

4.4.2 Host Settings

Host Name. Pushing the fourth rotary will open the on screen keyboard to allow the user to enter a new name for the device (touchscreen). [OK] when done.

Display

- Screen Brightness. High, Medium (default), Low, Very Low
- Screen Dimming. The screen will dim to Very Low when there is no activity. Timeout time: 1,2 (default),3,5,10 or 15 minutes.
- Touchscreen sensitivity: Low, Medium (default), High.

4.4.3 2W Audio (A,B)

Configure power settings for 2-wire audio sources and perform nulling.

- Interface - power settings
 - Power detected? Yes/No
 - Power Enabled/Disabled (default = disabled)
 - Mode Clear-Com/RTS (default = Clear-Com)
- Nulling: 2W A and 2W B. Press the rotary control (Start) to perform a null. Nulling is only available if power is detected.

4.4.4 2W Audio (C,D)

See 2W Audio (A,B)

4.4.5 Discovery

- Discover FSII TCVR.
 - Lists all FSII IP transceivers visible on the network. Select the transceiver you wish to register (third rotary). Select **Register** and push the rotary (fourth rotary) to begin the connection sequence.
- Discover FSE TCVR.
 - Lists all FS Edge transceivers visible on the network. Select the transceiver you wish to register (third rotary). Select **Register** and push the rotary (fourth rotary) to begin the connection sequence.

Deregister will remove the transceiver from the system. You will only see the **Deregister** option if the transceiver has been already registered.

4.4.6 Transceiver

Lists all registered transceivers. You can view and edit **Label** and **Cable Comp (E1 only)** here. Pushing the fourth rotary will open the onscreen keyboard (touchscreen). [OK] when done.

Note: *Cable Comp is the same as Cable Length Offset.*

- FSII IP. Version, Label.
- FS Edge. Version, Label.
- FSII E1. Version , Label, Cable Comp.

4.4.7 Networking

Management

Configure and view:

- LAN Port Assignment
- DHCP **Enabled**/Disabled
- IP Address (read only when DHCP is Enabled)
- Subnet Mask (read only when DHCP is Enabled)
- MAC Address (read only)

Push the fourth rotary to open the on screen touchscreen keyboard to change IP and Subnet. [OK] when done. The keyboard is only available when DHCP is disabled.

Note: *When changing from DHCP **Enabled** to DHCP **Disabled**, the address previously assigned by the DHCP server will be set as the static address. This can cause IP conflicts so you must change the address to one not provisioned by the DHCP server.*

AES67 (for IP transceivers)

The section of the menu is read only and only shown if the AES67 connection has been configured with a LAN port from the CCM. It shows:

- LAN Port Assignment
- DHCP Enabled/Disabled
- IP Address
- Subnet Mask
- MAC Address

Dante

The section of the menu is read only and only shown if the Dante connection has been configured with a LAN port from the CCM. It shows:

- LAN Port Assignment
- IP Address
- Subnet Mask
- MAC Address

4.4.8 Administration

- Beltpacks
 - Over the Air: Press rotary four to **Start OTA**. Put the Arcadia in pairing mode for OTA registration of beltpacks (600 seconds).
 - BP Role List Sorting:
 - Role Number
 - Alphabetical
 - Battery type: use this setting if the beltpacks are not using the supplied Li-ion batteries.
 - Alkaline (default)
 - NiMh (for use in high pressure environments)
- Software
 - Current version
 - Update software from a file on a USB (insert into USB on front of Arcadia)
- License
 - Connections - current connected ports on this Arcadia
 - Licensed Ports
 - Total Ports
 - Wireless Ports
 - HelixNet Ports
 - I.V. Direct
 - Dante
 - Any Ports. Licensed ports can be allocated to Wireless, HelixNet, Dante or Any. This is a way to control your system resources. A port allocated to Wireless (for example) will not accept connections of any other type. Ports are able to accept all connections by default (Any). Port type is assigned in the CCM: **CCM > Hardware > Resources > Licensed Ports > Type**.
- Reset

- Reboot
- Reset to Default. Reset here will reset role, channel and network details. You will need to **Add** your transceivers back into the system after reset. HelixNet devices will revert to default configuration
- Reset CCM Password
- Support Info
- Settings
 - Save
 - Restore
- CCM Access
 - Username
 - Default password
- Hardware (view only)

Information is for troubleshooting purposes only. Please note: the serial number in this section is the electronic main board serial number, not the device serial number.

5 The Core Configuration Manager (CCM)

This chapter describes the main pages of the Core Configuration Manager (CCM). It contains the following sections:

- 5.1 CCM Introduction 46
- 5.2 Changing the CCM Password 49
- 5.3 Setting the Management IP from the CCM 49
- 5.4 Saving and Restoring System Configuration 50
- 5.5 Resetting to Default 51
- 5.6 Hardware Page Overview 52
- 5.7 Host Page 53
- 5.8 Configuring the Network 54
- 5.9 Upgrading 57
- 5.10 Setting Up the Wireless Beltpack System 59
- 5.11 Resources Page 61
- 5.12 Configuration Page Overview 67
- 5.13 Channels and Groups 68
- 5.14 Channels Page 70
- 5.15 Groups Page 76
- 5.16 Roles Page 83
- 5.17 Logic Page 93
- 5.18 Status Page Overview 97

5.1 CCM Introduction

The CCM is an easy-to-use browser-based software tool with intuitive menus that enable you to quickly set up, configure and edit your system. It provides an overview of all the system components and interfaces. It is password protected and suitable for use in light sensitive environments.

At-a-glance guide to using the Core Configuration Manager (CCM)

HARDWARE



This is where you will initially set up your system and resources

- Register IP transceivers
- Register beltpacks
- Network setup
- Set 5 GHz channels on transceivers
- Interface port settings

CONFIGURATION

This is where you will configure the intercom aspect of your system: channels and audio keys

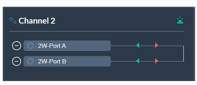

Add ports to channels



Roles: beltpacks, Station and other endpoints

STATUS

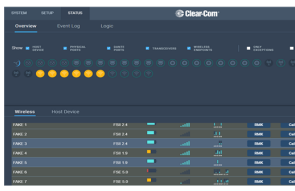

This section provides detailed status of system overview, information and performance

5.1.1 CCM Configuration and Information Icons

Pencil icon 

Click to label this device

Cog icon 

Click to go to configuration options

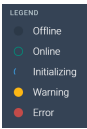
Status legend 

Click for status information

The CCM makes use of context sensitive navigation to help with troubleshooting and configuring specific devices. For example, from a beltpack in the **Resources** page, click the cog icon to go to role configuration for this beltpack.

Hover over an icon, it will enlarge if it is clickable.

5.1.2 Compatible Internet Browsers

You can access the CCM using the following internet browsers:

- Chrome
- Safari
- Firefox
- Microsoft Edge

5.1.3 Accessing the CCM

1. Make sure that the Arcadia is connected to a network using the LAN connector that is configured for management (Default LAN 1) on the rear panel of the device
2. Open a supported internet browser on a desktop that is connected to the same network as the Arcadia.
3. In the browser address field, enter the IP address of the Arcadia. You can find this from the front panel menus, see [Introduction to Configuring from the Front Panel on page 36](#). The login screen appears:

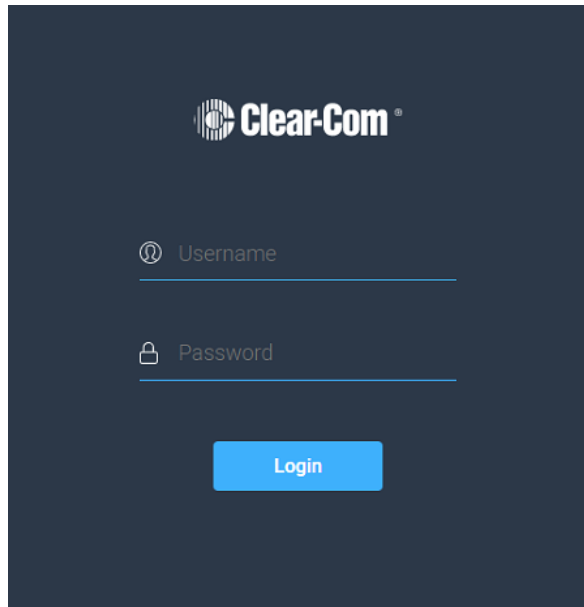

If you enter an incorrect user name or password, an error message appears and you are prompted to re-enter your user credentials.

4. Enter the username and password, and then click **Login**.

The default values are:

- username: **admin**
- password: find the default password in the front panel menu system, see [Passwords, Addresses, Reset to Default, Save and Restore Configuration on page 37](#).

Note: *The username and password are case sensitive.*

The CCM **Hardware** page opens.

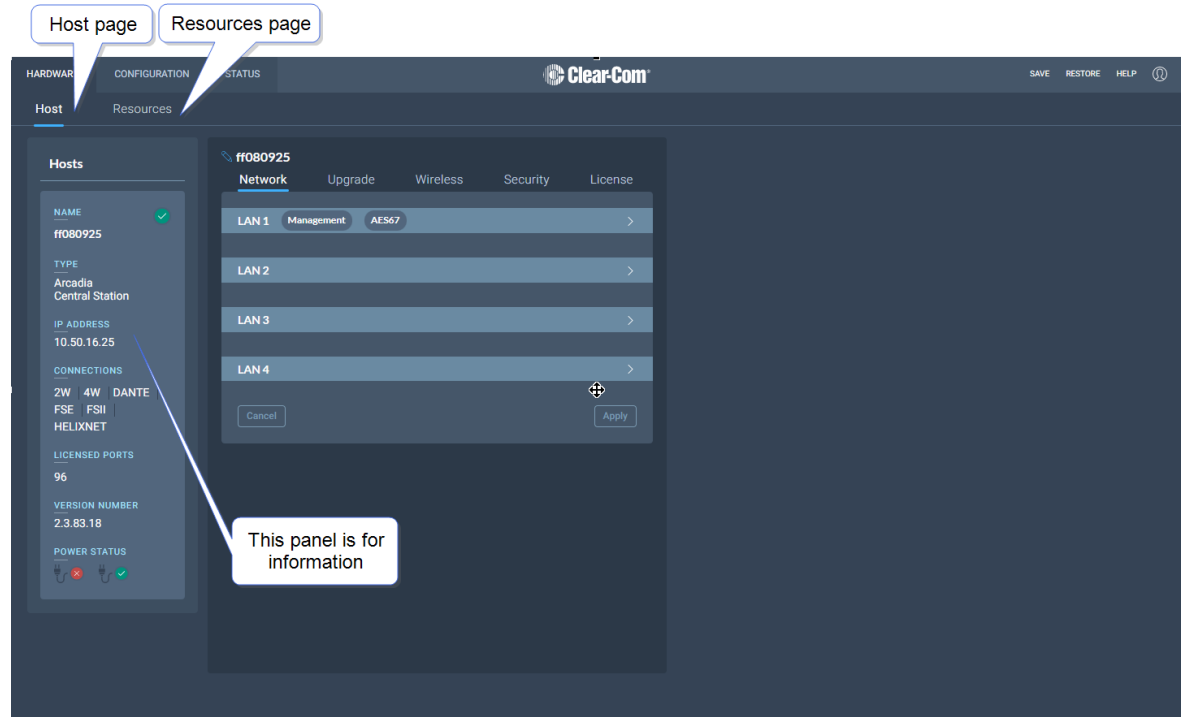

Note: On first opening the CCM, the **Hardware** page opens. On subsequent occasions, the **Status** page opens.

Delete this text and replace it with your own content.

5.2 Changing the CCM Password

Change the password to one of your own choosing in the top right corner of the navigation bar.

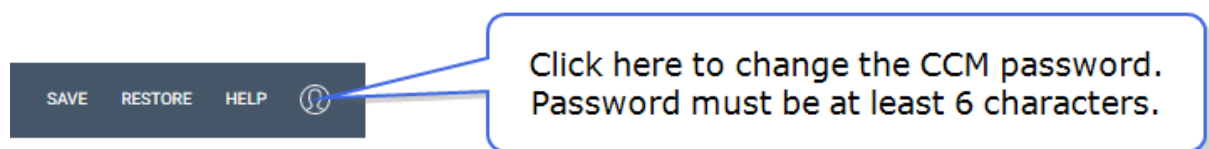

Note: You can reset your password to the default at any time from the Arcadia front panel menus.

5.3 Setting the Management IP from the CCM

To access the CCM, input the Management IP address into a browser. Find the management IP address of the Arcadia in the front panel menu system: **Menu>Networking>Management**.

1. In the CCM, navigate to **Hardware >Host**.
2. In the Network tab, click **Management**.

3. Select **Static**.
4. Enter the required IP address and press the [Enter] key.

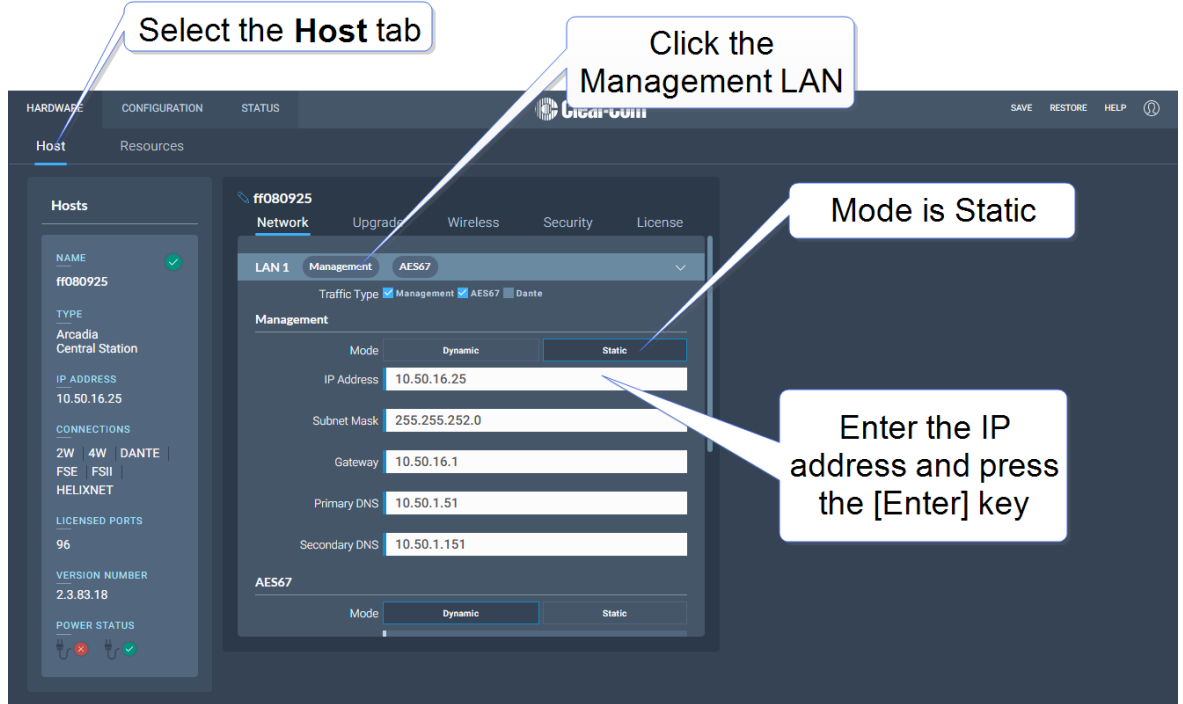

5. For more information, see: [LAN Configuration Rules on page 54](#).

5.4 Saving and Restoring System Configuration

Clear-Com recommends that you make a backup of your system configuration using the Save option that is available in the CCM and the front panel menu system.

5.4.1 Saving System Configuration in the CCM

The **Save** and **Restore** options are available in the CCM top navigation bar.



When you click **Save**, all system configuration; channels, roles and network details are saved to a file (.cca) on your computer.

5.4.2 Restoring System Configuration

Your system configuration can be restored to the Arcadia at any time using the **Restore** button in the CCM and also from the front panel menu system.

On restore, the saved configuration is reapplied to the Arcadia. The following aspects of the configuration are optionally restored:

- Network settings (IP addresses)
- Over The Air system ID.

You do not get these options when restoring by USB directly to the Arcadia. If you want to restore system settings taken from different Stations, you must use the CCM Restore option, as restoring directly from the Arcadia in this situation would restore network and OTA system ID and IP and could cause wireless ID conflicts.

5.5 Resetting to Default

Your Arcadia can be reset to default settings either from the front panel menus or from the Core Configuration Manager (CCM).

Note: *When you use a pin reset on front the front of the Arcadia the device power cycles (reboots).*

5.5.1 Resetting to Default from the CCM

1. In the CCM, navigate to **Status > Overview > Host Device**.
2. Select **Reset to Default**.
3. From the confirmation dialog box, click **Reset to Default**.
4. The device will reset to factory defaults and reboot.

When resetting to default from the CCM, network settings are not reset, and the password is also not reset. This is not the case when resetting to default from the front panel menus. After reset to default, you will need to re-discover your IP transceivers. HelixNet user stations will revert to default configuration.

5.6 Hardware Page Overview

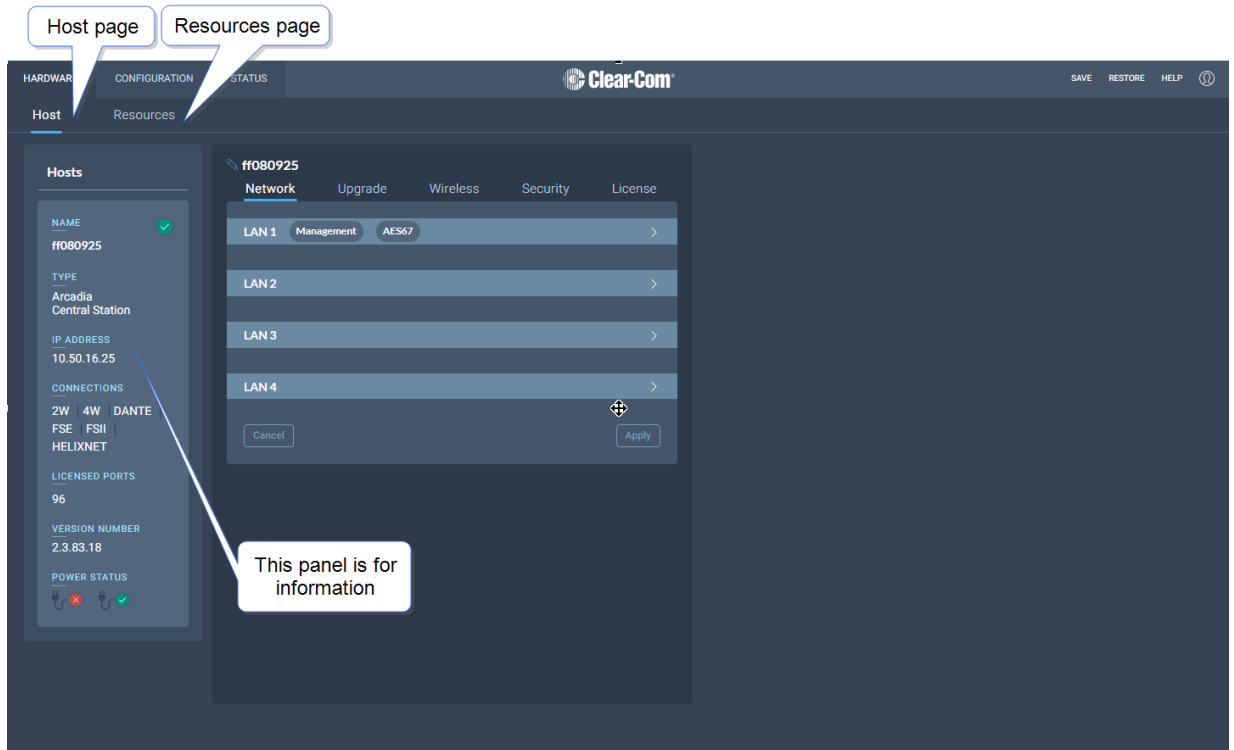

The Hardware page of the CCM is where you set up your system. It has two pages:

- The Hosts page where you can set up your Arcadia Central Station settings. See [Host Page on page 53](#)
- The Resources page where you can set up and configure the intercom resources that are connected to your central station. See [Resources Page on page 61](#)

5.7 Host Page

To configure the Arcadia, settings, navigate to **Hardware > Host**.

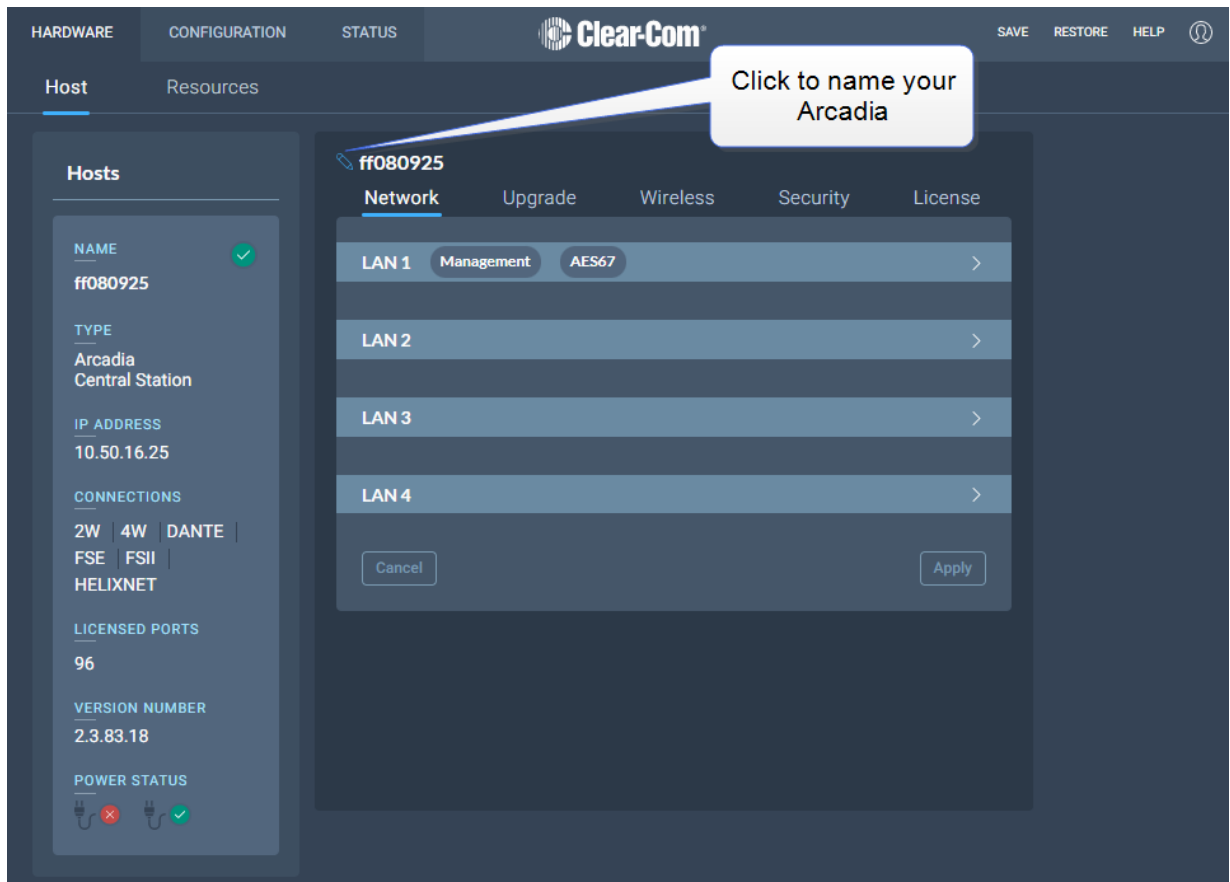

Here you can:

- Configure the network
- Upgrade the Arcadia and connected resources
- Change the following wireless beltpack system settings:
 - Beltpack administration pin numbers
 - FS Edge wireless region (important for system compliance)
 - FSII battery type, if you are not using the supplied Li-ion batteries you may use Alkaline or NiMH type batteries
- Configure security settings
- Add new licenses

Click the pencil icon  to name your Arcadia .

5.8 Configuring the Network

Your Arcadia Station has 4 LAN ports. Click on a dropdown arrow to configure network traffic and details for each port.

After changing the network configuration, you must click **Apply** or [Enter] key.

For information see: [LAN Configuration Rules on page 54](#).

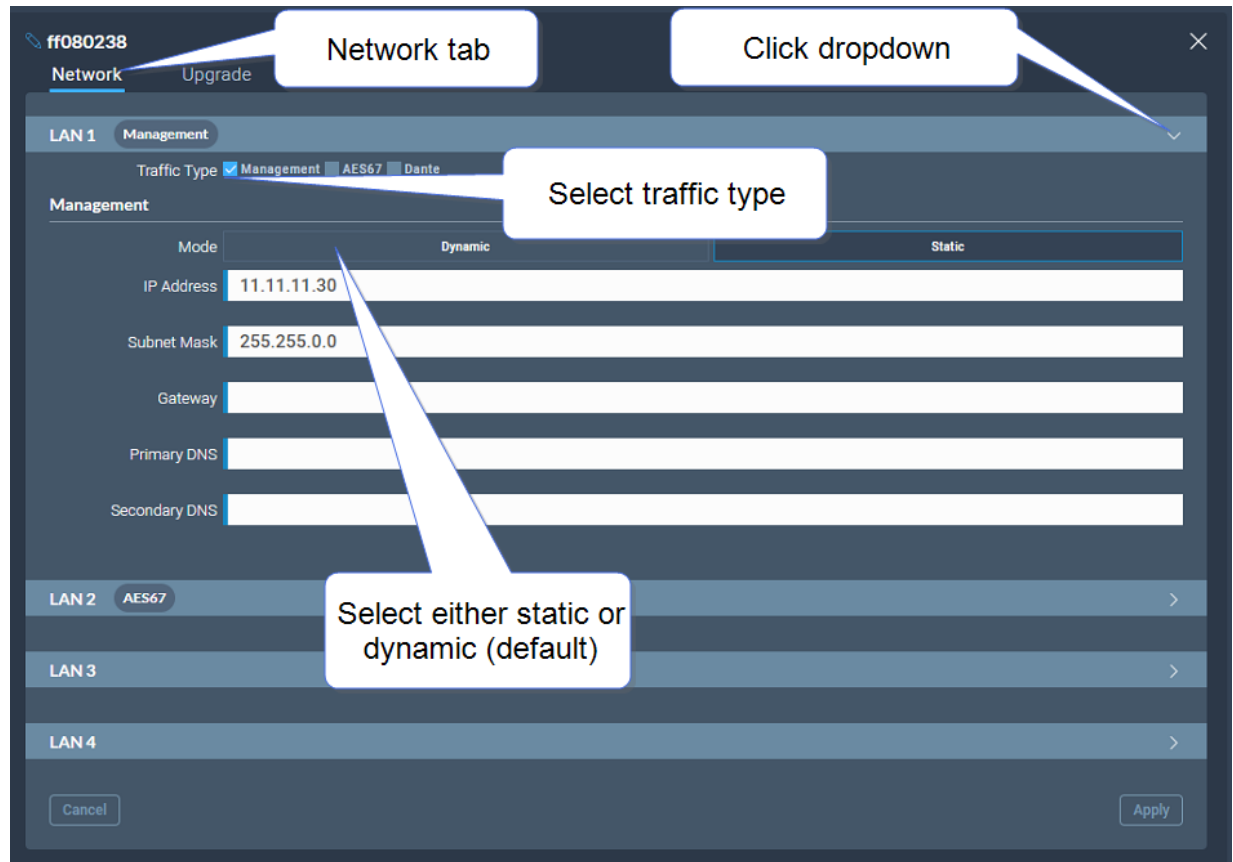

5.8.1 LAN Configuration Rules

Note: Do not plug any two LAN ports into the same LAN or VLAN. This can create a network loop affecting IP stability.

Note: Configuring/changing the AES67 IP address will cause the Arcadia to reboot.

AES67 Rules

- AES67 should not be on the same subnet as Management unless on the same LAN port
- AES67 cannot be on the same LAN port as DANTE primary or secondary

Note: Clear-Com recommends that you configure AES67 port on the Station to a Static IP address if there is no third-party DHCP server on the network.

IP Rules

- The IP addresses cannot be in the reserved range: 10.0.0.0-10.0.0.7
 - The subnet mask may cause an overlap with the reserved range
- The IP addresses cannot be in the LQ tunnel range 172.23.xxx.xxx
- The IP addresses cannot be in the localhost range 127.xxx.xxx.xxx
- The IP addresses cannot be in the multicast range 224.xxx.xxx.xxx-239.xxx.xxx.xxx

Static IP Rules

- The static IP addresses cannot be in link local range: 169.254.xxx.xxx

Note:

Clear-Com recommends that you configure AES67 port on the Station to a Static IP address if there is no third-party DHCP server on the network.

Dante Rules

- Dante primary and secondary cannot be on the same LAN port (rear connector)

Management Rules

- You cannot disable the Management LAN.

5.8.2 AES67 Network - PTP Follower Configuration

Arcadia and Edge v. 3.0 and upwards

By default, the intercom stations (Arcadia and Edge) have clocking status: Reference (IEEE 1588 Master). Change the status of the intercom station clocking function to Follower (IEEE 1588 Slave) by enabling **PTP Follower Mode**.

PTP Follower Mode

- **Enabled:** The intercom station is set as PTP Follower
- **Disabled** (default setting): The intercom station is set as PTP Reference

Setting the PTP clocking status of your intercom stations

1. In the CCM, navigate to : **Hardware > Host > Network**[select the LAN that has been configured for AES67] > **PTP Follower Mode**
2. Select **Enabled**
3. Click **Apply**

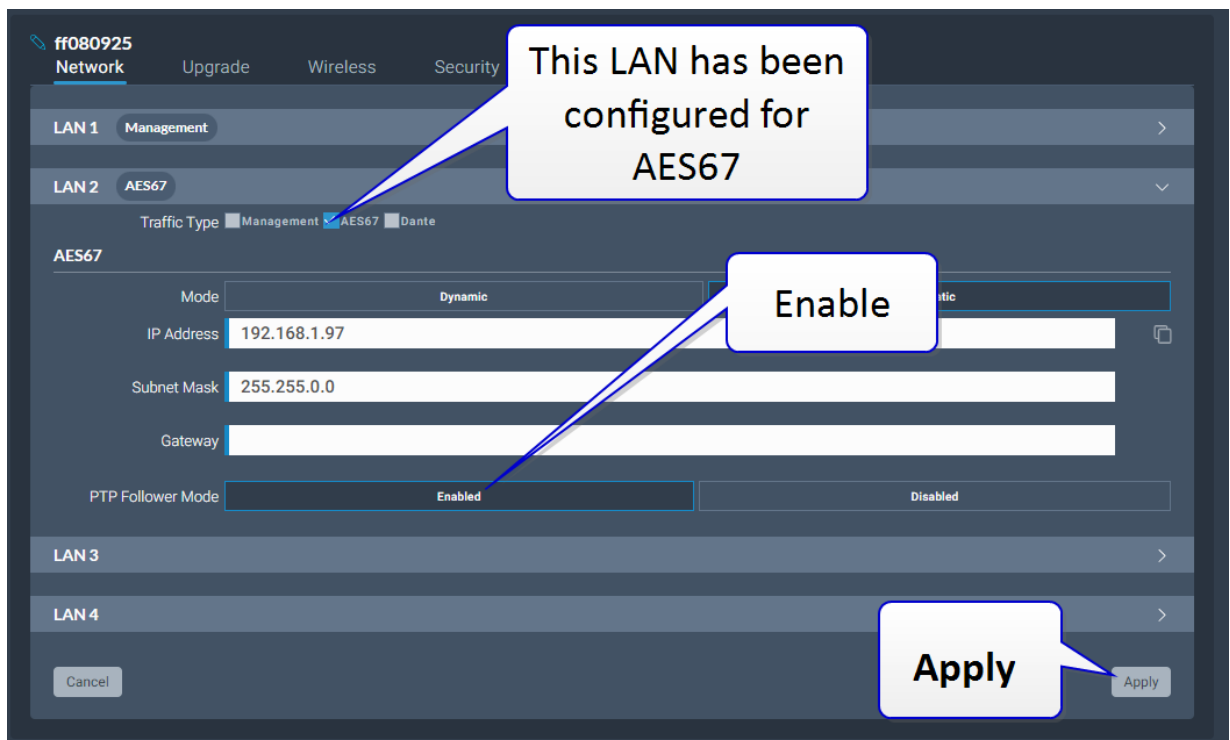

The system will warn you that there must be a Reference clock on your network. While the clock is synchronizing (or if there is no PTP Reference clock on your network) you will see **Status FREERUN** in the device **Stats** tab. When the clocks are synchronized, you will see **Status LOCKED**.

In the CCM navigate to : **Status > Overview > Host Device > Stats:**

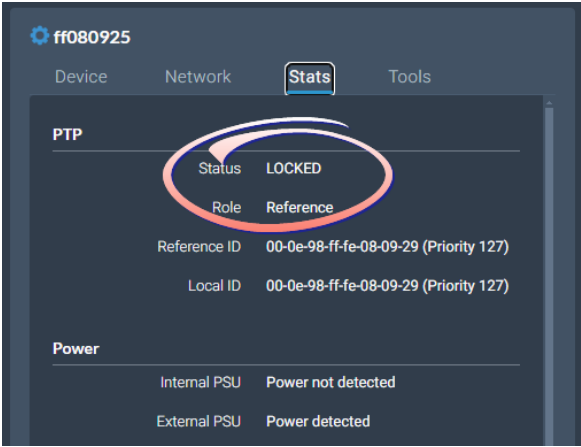
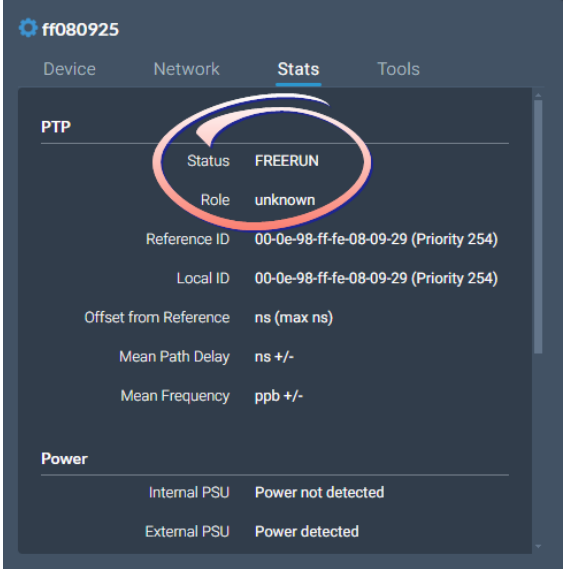

For information and history, also look in the event log: **Status > Event Log.**

5.9 Upgrading

To upgrade the Arcadia and connected resources:

1. Select the **Upgrade** tab.
2. **Select File** then navigate to where the upgrade file is stored on your computer.
3. Select the file and when the **Upgrade** button lights, click it. This begins the upgrade process.

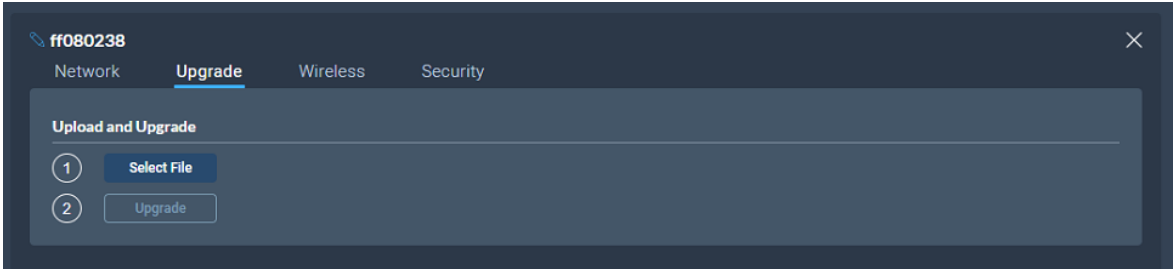

| Device to upgrade | File extension |
|---|----------------------------|
| Arcadia, FS II IP TCVR, FS Edge IP TCVR | .ccf |
| FS II beltpack, FS II E1 TCVR | .fww |
| FS Edge beltpack | .ccu |
| HelixNet | See HelixNet Upgrade below |

Note: *Arcadia validates firmware versions to internal hardware. In some instances, Arcadia and its components cannot be downgraded. In these instances use a newer firmware version.*

5.9.1 Upgrading using the CCM

1. In the CCM, navigate to **Hardware > Hosts (click anywhere on the Hosts panel) > Upgrade**.
2. Press **Select File** and select the file containing the updated firmware.
3. When the file is uploaded, the **Upgrade** button will be enabled.
4. Press the **Upgrade** button.
5. The upgrade process will start and the Base Station will reboot before being available again.
6. The new version of the firmware will be displayed in the **Hosts** panel.

5.9.2 Upgrading using a USB stick

1. Copy the firmware file onto a USB stick. The file must be at the top level of the USB drive, not within any folders.
2. Insert the USB into the USB port on the front of the Base Station.
3. Press the **Menu** button.
4. Using the rotary controllers, navigate to **Administration > Software > Update**.
5. The display will show the available firmware files stored on the USB. Select the one you require.
6. Press the 4th rotary encoder. The unit will upgrade and then reboot.
7. To check the current firmware version, in the menu system navigate to **Administration > Software > Current**. The current software version is displayed in the 4th menu screen.

5.9.3 HelixNet Upgrade

Upgrades to the HelixNet system are included with the Arcadia software. The HelixNet system requires that all connected devices have the same firmware. Therefore, any mismatches that are detected will cause an immediate and automatic upgrade (or downgrade) to the HelixNet devices on connection. The HelixNet system will also upgrade automatically when the Arcadia Central Station is upgraded.

Note: *HelixNet Endpoints manufactured in January 2023 (serial number ends with C00 or higher letter/number) or later can only be used with Arcadia version 2.8 or HMS-4X version 4.4. These endpoints cannot be used with older versions due to differences in hardware components.*

5.10 Setting Up the Wireless Beltpack System

Select the **Wireless** tab.

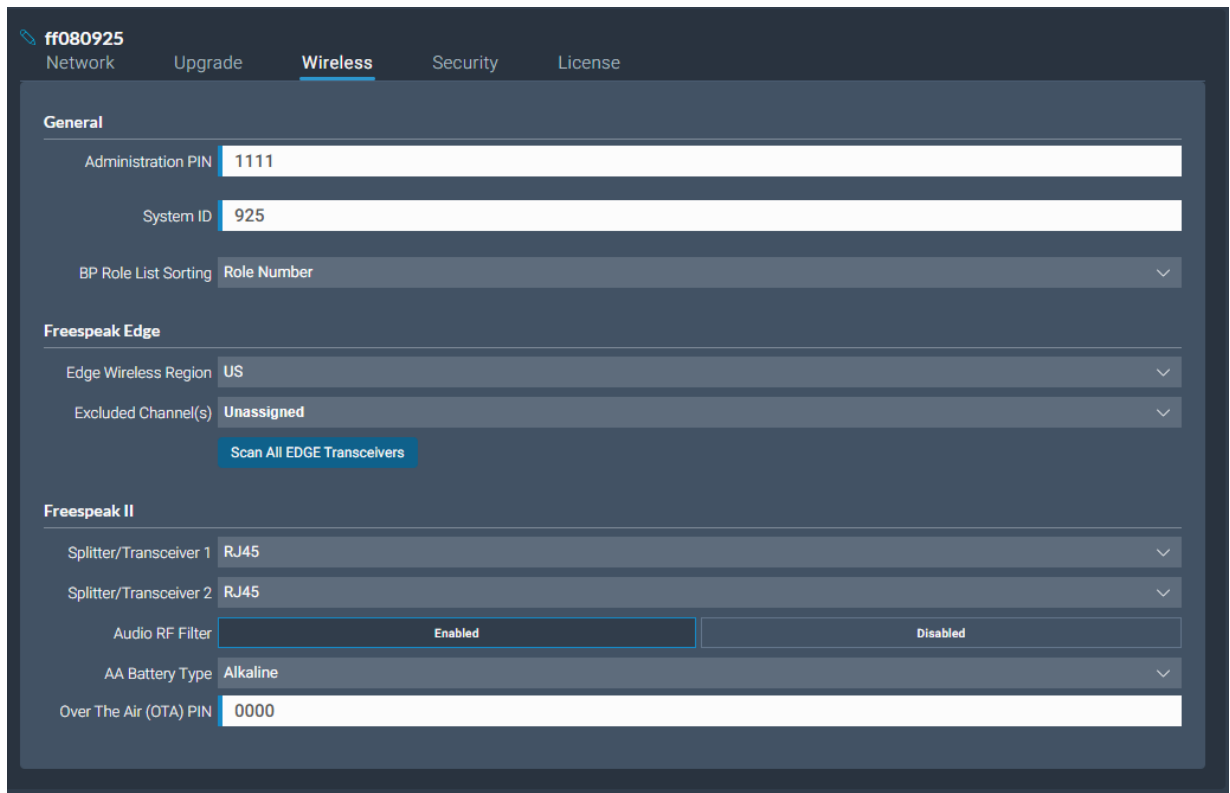

ff080925
Network Upgrade **Wireless** Security License

General

Administration PIN

System ID

BP Role List Sorting

Freespeak Edge

Edge Wireless Region

Excluded Channel(s)

[Scan All EDGE Transceivers](#)

Freespeak II

Splitter/Transceiver 1

Splitter/Transceiver 2

Audio RF Filter Enabled Disabled

AA Battery Type

Over The Air (OTA) PIN

From the Wireless tab, you can set or view the following System and Station settings.

5.10.1 System

- The administration pin for your wireless system, used by the beltpack to be able to access privileged functionality
- System ID. This is used to differentiate this system's RF signals from those of other systems
- Beltpack role list sorting:
 - Role number
 - Alphabetical

5.10.2 FreeSpeak Edge

- The wireless region for your FreeSpeak Edge beltpacks. The region set here **MUST** match the hard-coded setting on your Edge transceiver or the system will not work. You will see an error flag in the **Status** page if the regions do not match. Please contact your Clear-Com representative if you have any difficulties with this.

- Select from a list of 5 GHz channels that you can exclude and prevent transceivers from using
- Scan all transceivers. Use this feature to scan the local 5 GHz RF space. All available channels will be scanned, and traffic reported. Each transceiver will be scanned and the system will report on the RF performance of selected channels. To view results of the scan and adjust channels, navigate to: **Hardware > Resources > Transceivers > [select a transceiver to view] > Wireless Channels**

The screenshot shows the configuration interface for a device with ID **ff080925**. The **Wireless** tab is selected. The **General** section includes fields for Administration PIN (1111), System ID (925), and BP Role List Sorting (Role Number). The **Freespeak Edge** section features a dropdown for Edge Wireless Region (US), a dropdown for Excluded Channel(s) (Unassigned), and a **Scan All EDGE Transceivers** button. The **Freespeak II** section includes two Splitter/Transceiver options (both RJ45), an Audio RF Filter (Enabled), AA Battery Type (Alkaline), and an Over The Air (OTA) PIN (0000). Three callout boxes provide instructions: 'Select any channels for exclusion' points to the Excluded Channel(s) dropdown; 'Wireless region' points to the Edge Wireless Region dropdown; and 'Scan all transceivers' points to the Scan All EDGE Transceivers button.

5.10.3 FreeSpeak II

- Splitter/Transceiver ports: select RJ45 or Fiber connectivity for each port
- Audio RF Filter (improve resilience to corrupt wireless transmission) - for use with E1 1.9GHz transceivers only
- AA Battery type. You can choose not to use the Li-ion batteries supplied with the beltacks, in which case you must specify battery type here. Choose between:
 - Alkaline (AA) batteries (default setting)
 - NiMH batteries for use in settings where air pressure is an issue (for instance on an underwater site).
- The OTA pin you need for over-the-air (OTA) registration of your FreeSpeak II beltacks.

5.11 Resources Page

Click the **Resources** tab to see the resources page. This gives an overview of the hardware and ports that are present. From this page, you can use the **Add Resource** button to:

- View a list of both discovered and registered IP transceivers
- Add/remove any discovered IP transceivers to/from the system
- View a list of both discovered and paired HelixNet devices
- Add/remove any discovered HelixNet devices to/from the system
- View a list of configured I.V. Direct ports, with connection status
- Add/remove I.V. Direct ports and enable/disable ports
- Register beltacks to the system
- Create Dante ports
- Adjust settings on interface ports: 2-wire and 4-wire
- Allocate **Licensed Ports** for use with different connection types: **Any, Dante, Wireless, I.V. Direct, HelixNet**. This allows you to keep track of how you are using the licensed port capacity that you have, and avoid being unable to connect due to lack of available port capacity.

5.11.1 Configuring System Resources

- Transceivers
- Endpoints
- Physical ports; 2-wire, 4-wire, Stage Announce, Program
- I.V. Direct ports
- Dante ports
- Licensed ports

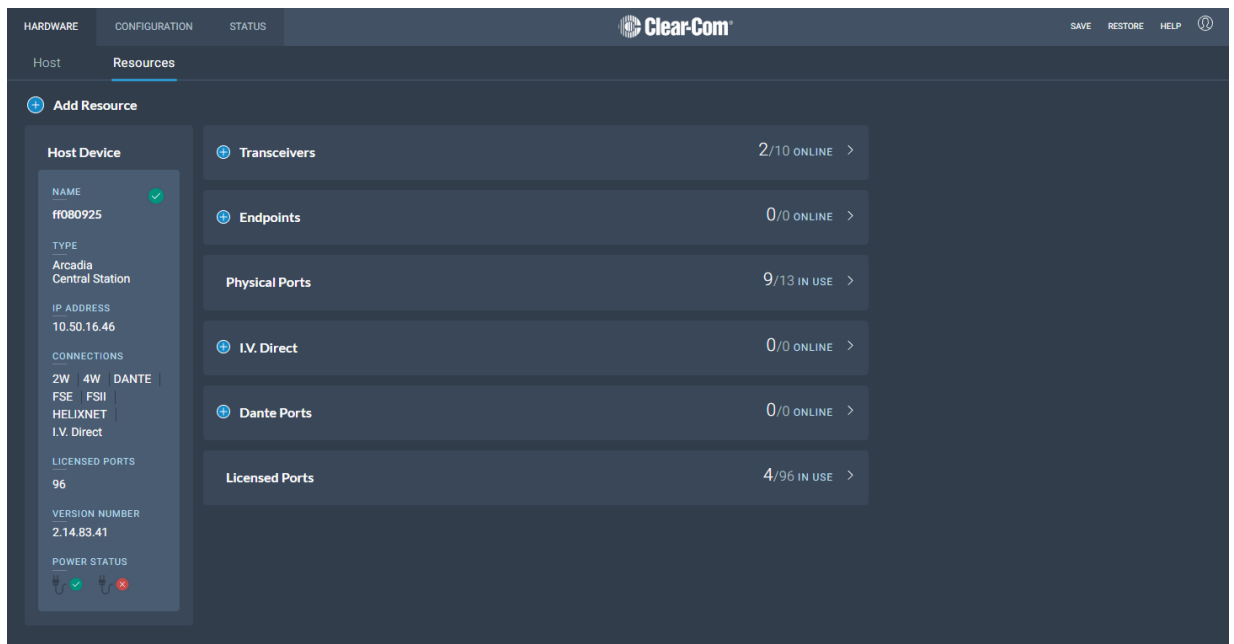

Transceivers

Click the dropdown arrow to see transceivers connected to your system. Select a transceiver to configure it or view details.

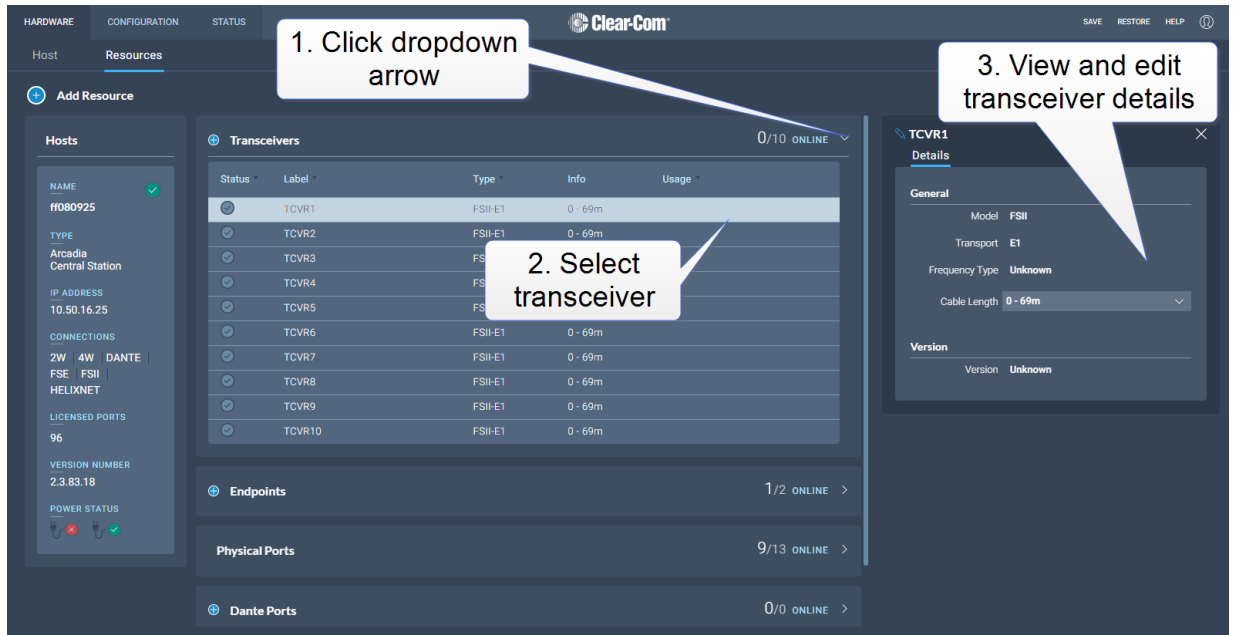

For IP transceivers you will also set networks details in this page. For Edge transceivers you will configure channels and conduct a local area RF scan and set channels automatically for each transceiver.

Endpoints

If you click the down arrow in the **Endpoints** section of the screen you will see a list of connected Endpoints (FreeSpeak and HelixNet beltpacks, and HelixNet remote and speaker stations). Select an Endpoint to show configuration details such as:

- Fix/unfix a role. If a role is fixed to a beltpack, the user cannot select from a list of roles on powering on the beltpack.
- Reboot some devices.
- Unregister (FreeSpeak) or unpair (HelixNet) a beltpack from the system.

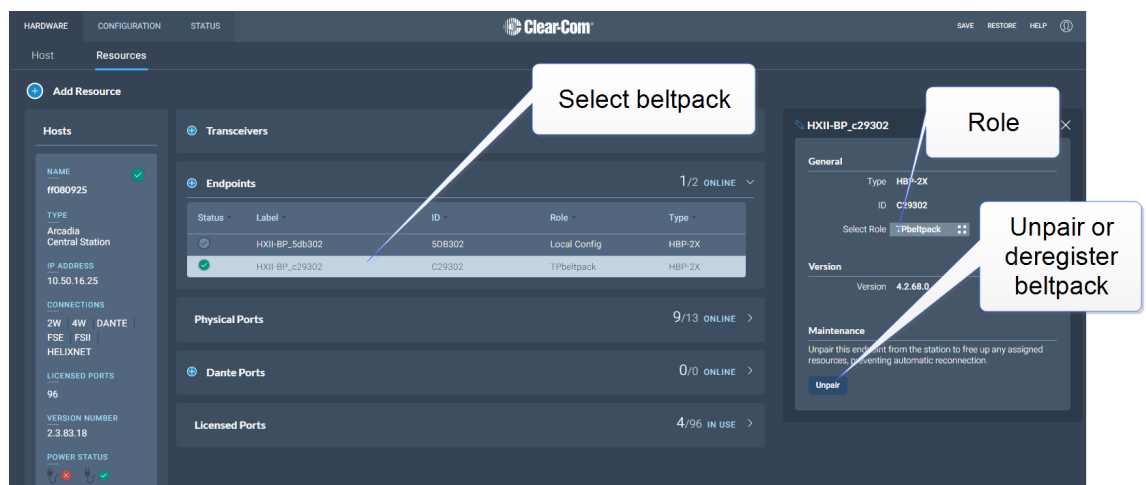

Physical Ports

Click the dropdown arrow to see the physical ports on your Arcadia. Select a port to configure it or view details.

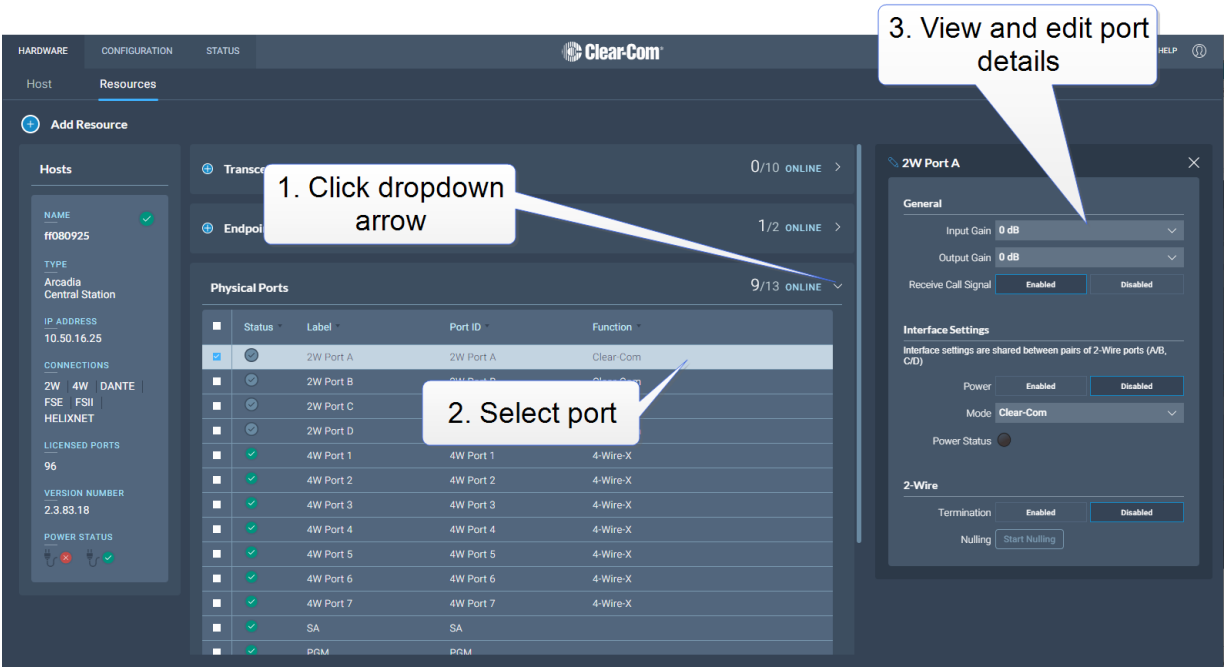

I.V. Direct Ports

Click the dropdown to see I.V. Direct connections configured on your Arcadia. Select a port to configure it or view details. I.V. Direct ports provide, for example, intercom expansion via LQ (analog ports, virtual client, SIP or radio connectivity) and intercom system bridging (Arcadia to Eclipse matrix or Arcadia to Arcadia). I.V. Direct ports can be used for communication with remote or distributed systems, and long distance.

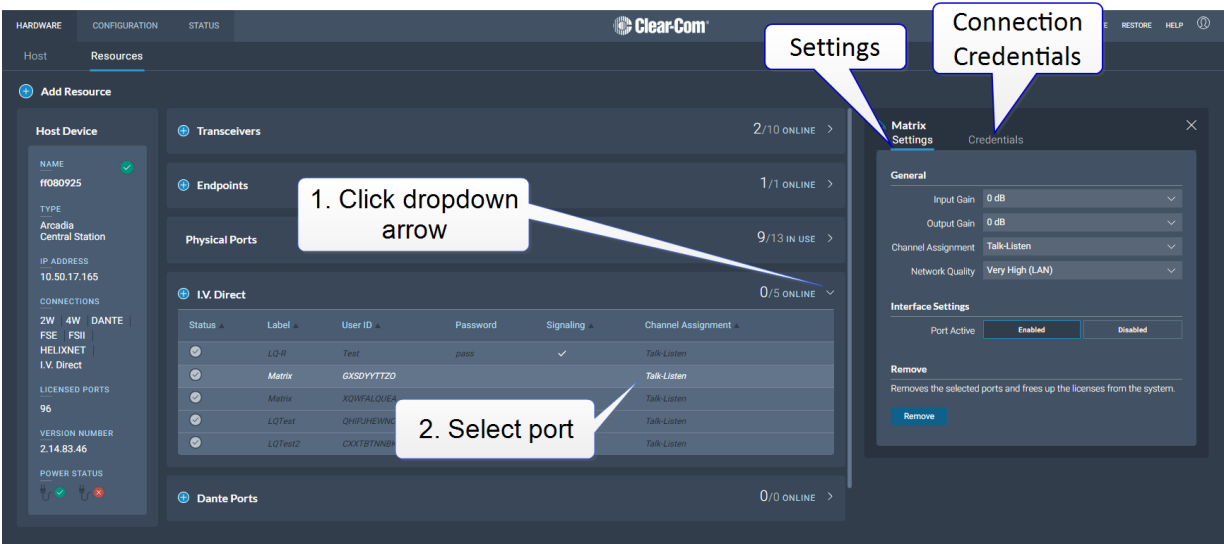

For more information see [Configure I.V. Direct in the Arcadia CCM on page 139](#)

Error messages - I.V. Direct

Click or hover on the red cross to see error messages

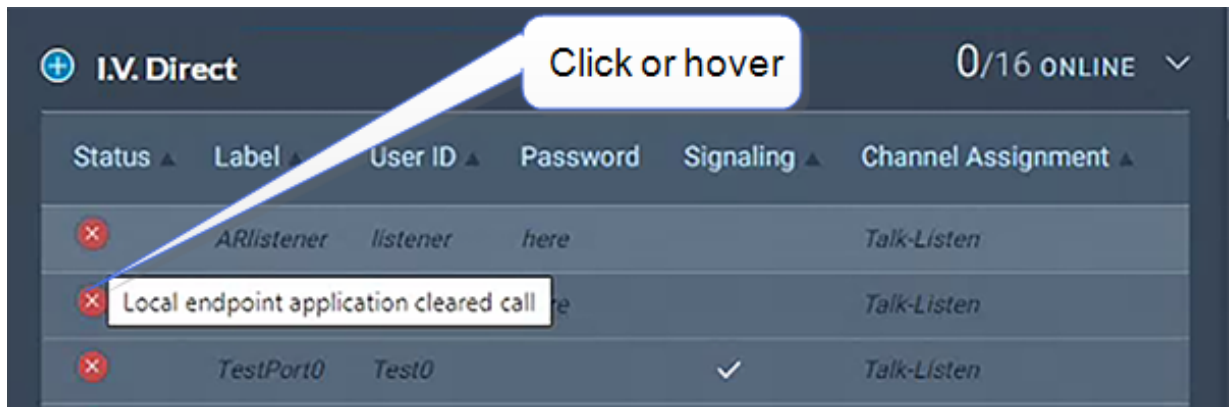

In the event of a connection failure you will see the following error messages:

| Message | Reasons for closing the connection |
|---|---|
| <p><i>Local endpoint application cleared call</i></p> <p>The local device has closed a connection</p> | <p>The License was removed on the local side (Arcadia) for an active I.V. Direct connection</p> <p>The username and password were changed on the local side (Arcadia) for an active I.V. Direct connection</p> <p>There are no free licenses for I.V. Direct ports on the local side</p> |
| <p><i>Remote endpoint application cleared call</i></p> <p>The remote device has closed the connection</p> | <p>The username and password were changed on the remote side (LQ/Arcadia/EHX) for an active connection</p> <p>The License was removed on the remote side (LQ/Arcadia/EHX) for an active connection</p> <p>The I.V. Direct port was disabled on the remote side (LQ/Arcadia/EHX) for an active connection</p> <p>There are no free licenses for I.V. Direct ports on the remote side</p> |
| <p><i>Call failed a security check and was ended</i></p> | <p>The username or password is wrong</p> |

Dante Ports

Click the dropdown arrow to see the Dante connections on your Arcadia. Select a port to configure it or view details.

Licensed ports

This section allows you to see and keep track of port licenses and how you are using them in your system. For example, if you know that you must have 14 wireless beltpacks connected, you can allocate 14 ports as 'Wireless' here. If you try to connect a device that you do not have a port type allocated for, the connection will be refused. Select use type for ports:

- Any (**default setting**) - in this case, any connection type is possible
- Dante
- Wireless
- HelixNet
- I.V. Direct

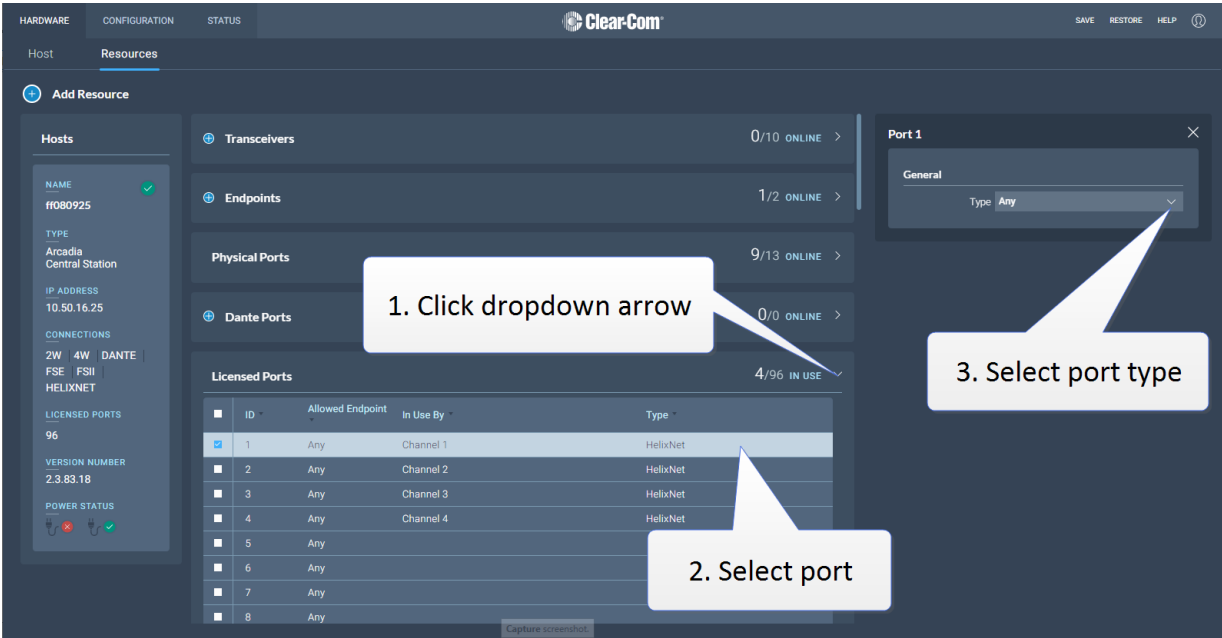

5.12 Configuration Page Overview

The screenshot displays the Clear-Com Configuration page. At the top, there are tabs for HARDWARE, CONFIGURATION, and STATUS. The CONFIGURATION tab is active, with sub-tabs for Channels, Groups, Roles, and Logic. The main content area is divided into three sections:

- Channels:** A table listing 8 channels with columns for Status, Label, Online, Talkers, and HelixNet. Channel 1 is highlighted.
- Channel 1:** A detailed view of Channel 1, showing it is HelixNet Enabled and Disabled. It lists components like PGM, Arcadia, Audio, Local Config, and Spots 1.
- Ports:** A table showing 1/15 assigned ports. It lists ports for 2W, 4W, SA, and PGM, with columns for Status, Label, Port Id, and Channel.

The **Configuration** page of the CCM is where you configure the intercom routing aspects of your system (add audio to channels and set up talk and call keys for beltpacks). It consists of four areas:

- Channels
- Roles
- Groups
- Logic (GPIOs)

The **Configuration** page enables you to:

- View existing channels and add new channels
- Add ports to channels
- View existing groups and add new groups
- View and edit roles for user stations
- View and edit General Purpose Inputs (GPIs) and General Purpose Outputs (GPOs)

5.13 Channels and Groups

Channels and groups are both essentially digital containers for audio sources, allowing communication between members.

5.13.1 Channels

A Channel operates as an intercom Partyline or conference. All members can talk to and listen to all other members, as long as they have keys to do so.

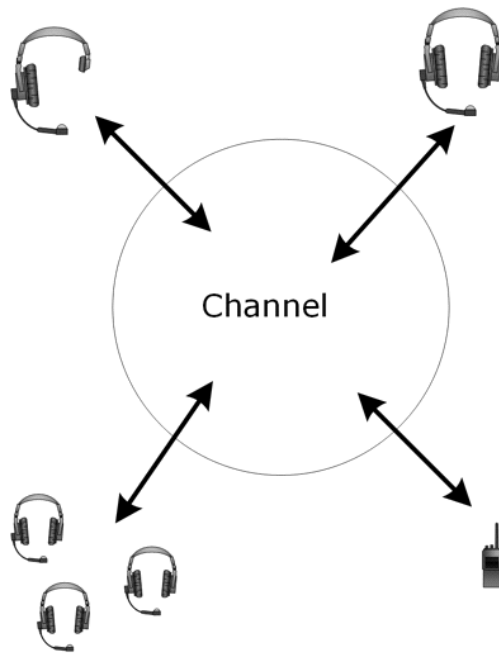

The default key behavior setting for a wireless beltpack in a Channel is **Talk and Forced Listen**. For more information, see **Key Behavior**.

5.13.2 Groups

A Group configuration enables an announcement or broadcast to a number of members at the same time.

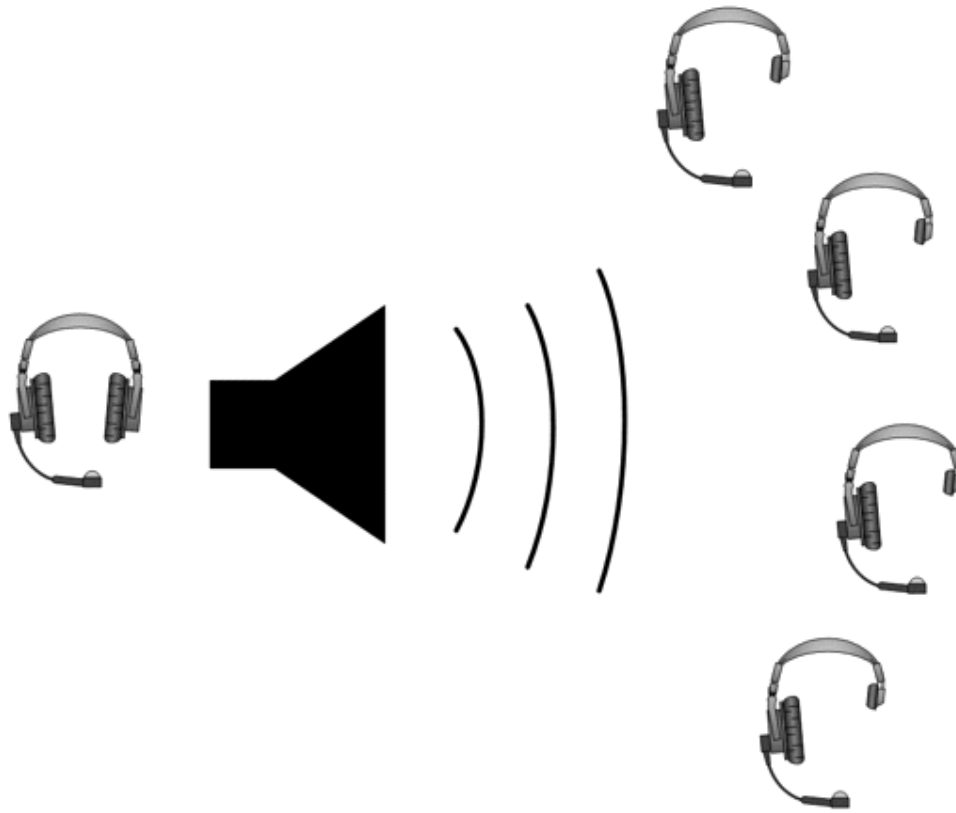

A group member can reply directly to the announcer using the **Reply** key. The other group members will not hear this.

To set up a group, you must first put the members in the Group. Then, when the members are in the Group, you can set up a key or keys to talk to it.

5.14 Channels Page

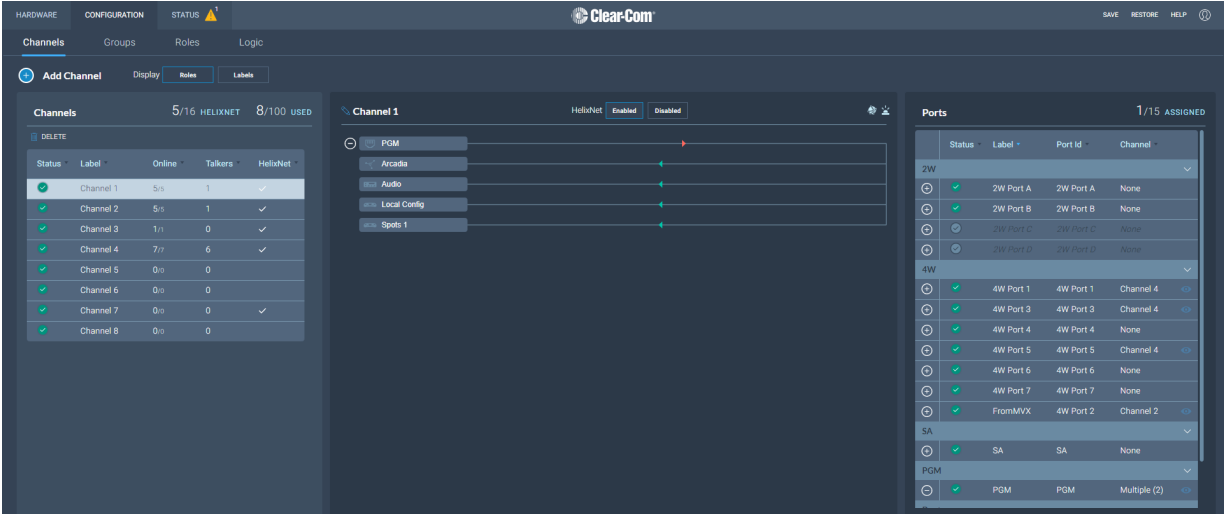

The Channels page enables you to view channels and add ports to channels. Audio keys are added to channels in the **Roles** page. The center panel on this screen shows the live state of audio routing.

5.14.1 Managing Channels

From the **Channels** tab, you can:

- View existing channels and add or remove new channels.
- View existing ports, and add or remove ports from the channel.

To access the **Channels** screen, navigate to **Configuration > Channels**. The Channels screen appears.

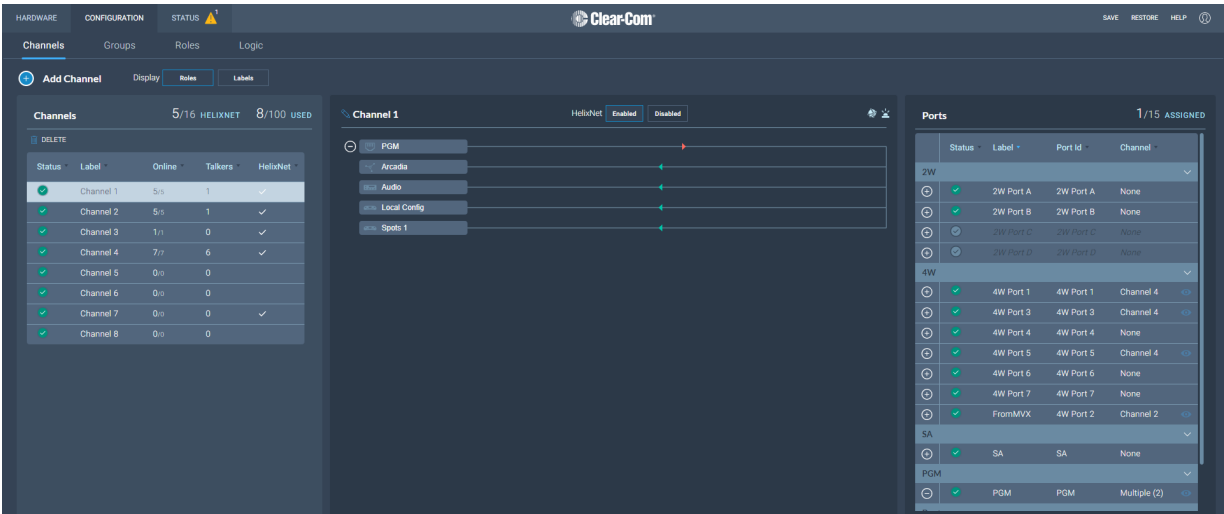

Viewing Information About a Channel

When you open the **Channels** screen, the left-hand panel displays a list of all the channels that are currently present. The following information is displayed for each channel.

The screenshot shows the 'Channels' screen with a table of channels. The table has columns for Status, Id, Name, Online, and Talkers. The 'Status' column contains green checkmarks for all channels. The 'Online' column shows '2/2' for Channel 1 and '0/0' for others. The 'Talkers' column shows '1' for Channel 1 and '0' for others. A callout points to a plus icon in the top left, another to a green checkmark, and a third to the '2/2' value. On the right, a callout points to '8/100 USED' and another to the 'Channel 1' label. A fourth callout points to the 'Talkers' column.

| Status | Id | Name | Online | Talkers |
|--------|----|-----------|--------|---------|
| ✓ | 1 | Channel 1 | 2/2 | 1 |
| ✓ | 2 | Channel 2 | 0/0 | 0 |
| ✓ | 3 | Channel 3 | 0/0 | 0 |
| ✓ | 4 | Channel 4 | 0/0 | 0 |
| ✓ | 5 | Channel 5 | 0/0 | 0 |
| ✓ | 6 | Channel 6 | 0/0 | 0 |
| ✓ | 7 | Channel 7 | 0/0 | 0 |

Callouts from the image:

- Click this icon to delete a channel (points to the plus icon)
- A green tick mark indicates that all configured ports are connected (points to the checkmark in the Status column)
- This indicates how many users are talking on this channel (points to the '1' in the Talkers column for Channel 1)
- The channel count indicates that eight out of a maximum of 100 channels (points to '8/100 USED')
- This is a label for the channel (points to 'Channel 1')
- This indicates how many configured ports are connected (points to '2/2' in the Online column for Channel 1)

Status

A green tick mark indicates that all the ports that are configured for the channel are connected. Otherwise, a warning triangle is shown.

Name

This field contains a label that enables you to identify the channel.

Note: A label can contain up to 10 characters. You can edit this label from the center panel.

Online

This indicates how many of the total channel members are online.

Talkers

This indicates how many members have active talk routes on this channel.

Display Roles or Labels

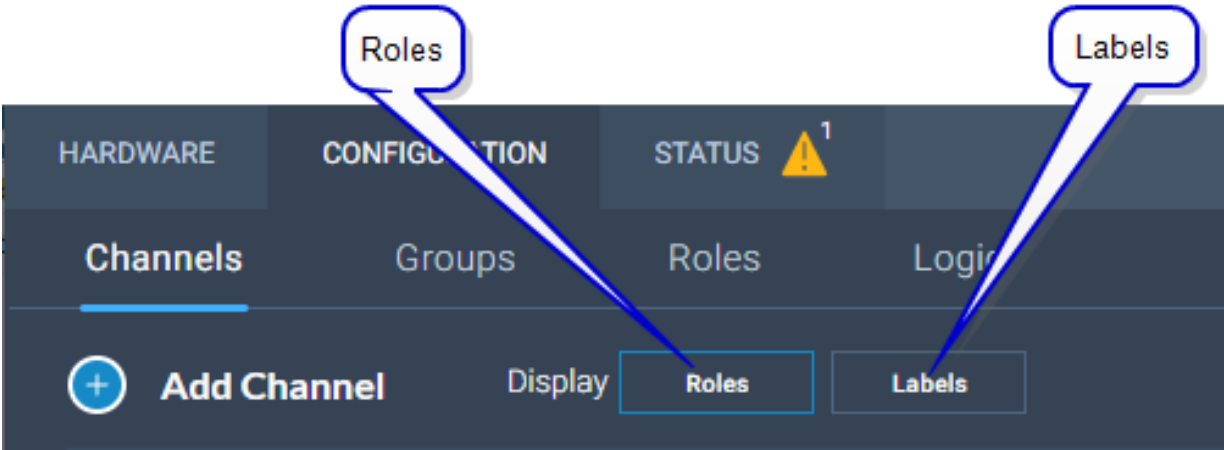

Display Roles



Display Labels

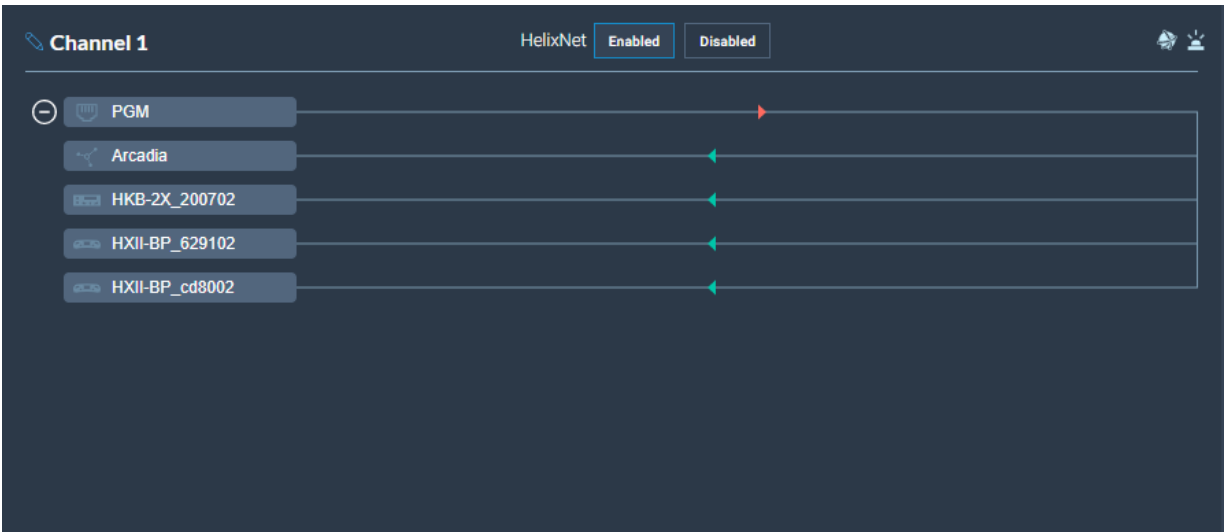

Adding a New Channel

To add a new channel:

1. Click the new channel icon . A new entry appears in the list of added channels.

Note: *You can only add new channels up to a maximum number (100).*

2. Add any required ports to the channel.

Adding Ports to a Channel

To add ports to a channel:

1. From the **Channel** panel, select the channel in which the port is to be added.
2. From the **Ports** panel, click the add port icon  of the port that you require.

| Status | Label | Port Id | Channel |
|------------|-----------|-----------|-----------|
| 2W | | | |
| | 2W Port A | 2W Port A | None |
| | 2W Port B | 2W Port B | None |
| | 2W Port C | 2W Port C | None |
| | 2W Port D | 2W Port D | None |
| 4W | | | |
| | 4W Port 1 | 4W Port 1 | Channel 1 |
| | 4W Port 2 | 4W Port 2 | None |
| | 4W Port 3 | 4W Port 3 | None |
| | 4W Port 4 | 4W Port 4 | None |
| | 4W Port 5 | 4W Port 5 | None |
| | 4W Port 6 | 4W Port 6 | None |
| | 4W Port 7 | 4W Port 7 | None |
| SA | | | |
| | SA | SA | None |
| PGM | | | |
| | PGM | PGM | None |

1/13 ASSIGNED

Click here to add this port to a channel

A green checkmark indicates that the port is online

This is a label that helps you to identify the port

This identifies the port. Changing the label does not affect the Port Id

This indicates how many of the total number of ports are assigned to the currently selected channel

Click on the eye icon to highlight the channels that the port is assigned to

This is the name of the channel that the port is currently assigned to

Stage Announcement

The port is now added to the channel, and appears in the list of ports in the center panel.

Channel 2

Click here to edit the channel label

Click here to remove the port from the channel

This is the label of the port

When this is lit it indicates that a call signal is active in this channel

The green arrows indicate active listen (left arrow). The red arrows indicate active talk (right arrow).

Removing Ports From a Channel

To remove a port from a channel:

1. From the **Channels** panel, select the required channel.

2. Click the remove icon  of the port that you want to remove.

The port is removed.

Deleting a Channel

To delete a channel:

1. From the **Channels** panel, select the channel that you want to delete.
2. Remove all the ports from the channel

Note: If you do not remove the ports, you will be prompted to do so in step 3.

3. Click the **More Actions** icon , and select **Delete**.

Enabling Channels for HelixNet

If you wish to use HelixNet in a channel, that channel must be enabled for HelixNet. By default, channel 1, 2, 3 and 4 are enabled for use with HelixNet products.

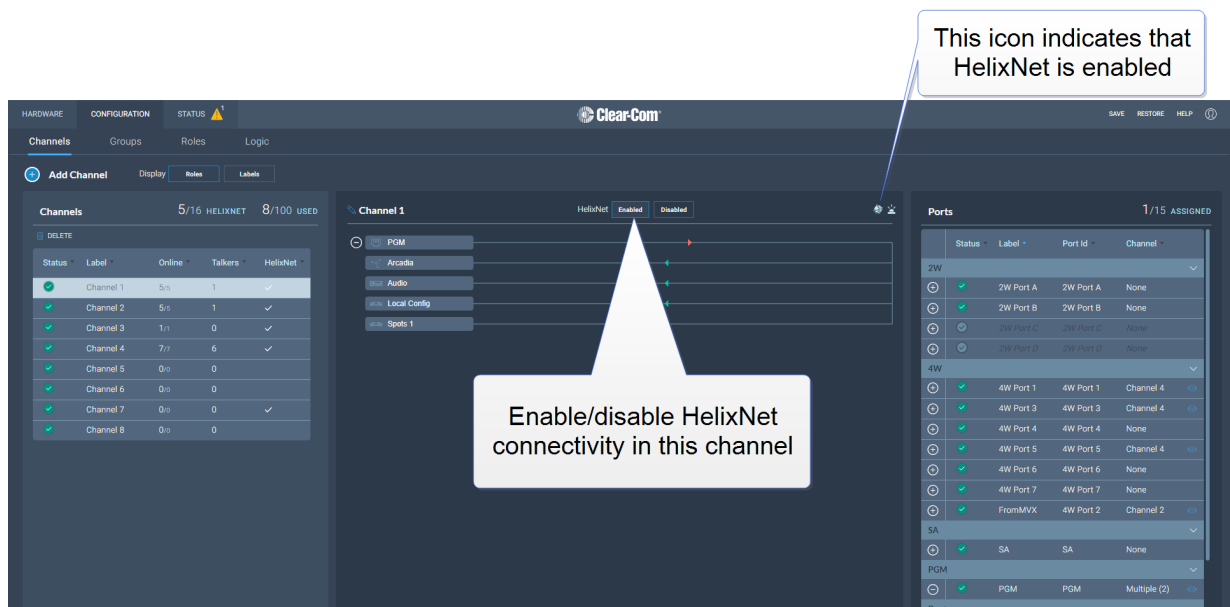

This icon indicates that HelixNet is enabled

Enable/disable HelixNet connectivity in this channel

| Status | Label | Online | Talkers | HelixNet |
|--------|-----------|--------|---------|----------|
| ✓ | Channel 1 | 5/5 | 1 | ✓ |
| ✓ | Channel 2 | 5/5 | 1 | ✓ |
| ✓ | Channel 3 | 1/1 | 0 | ✓ |
| ✓ | Channel 4 | 7/7 | 6 | ✓ |
| ✓ | Channel 5 | 0/0 | 0 | ✗ |
| ✓ | Channel 6 | 0/0 | 0 | ✗ |
| ✓ | Channel 7 | 0/0 | 0 | ✗ |
| ✓ | Channel 8 | 0/0 | 0 | ✗ |

| Status | Label | Port Id | Channel |
|--------|-----------|-----------|--------------|
| 2W | 2W Port A | 2W Port A | None |
| 2W | 2W Port B | 2W Port B | None |
| 2W | 2W Port C | 2W Port C | None |
| 2W | 2W Port D | 2W Port D | None |
| 4W | 4W Port 1 | 4W Port 1 | Channel 4 |
| 4W | 4W Port 3 | 4W Port 3 | Channel 4 |
| 4W | 4W Port 4 | 4W Port 4 | None |
| 4W | 4W Port 5 | 4W Port 5 | Channel 4 |
| 4W | 4W Port 6 | 4W Port 6 | None |
| 4W | 4W Port 7 | 4W Port 7 | None |
| 4W | FromMVX | 4W Port 2 | Channel 2 |
| SA | SA | SA | None |
| PGM | PGM | PGM | Multiple (2) |

Note: A HelixNet enabled channel will consume one of your licensed ports.

5.15 Groups Page

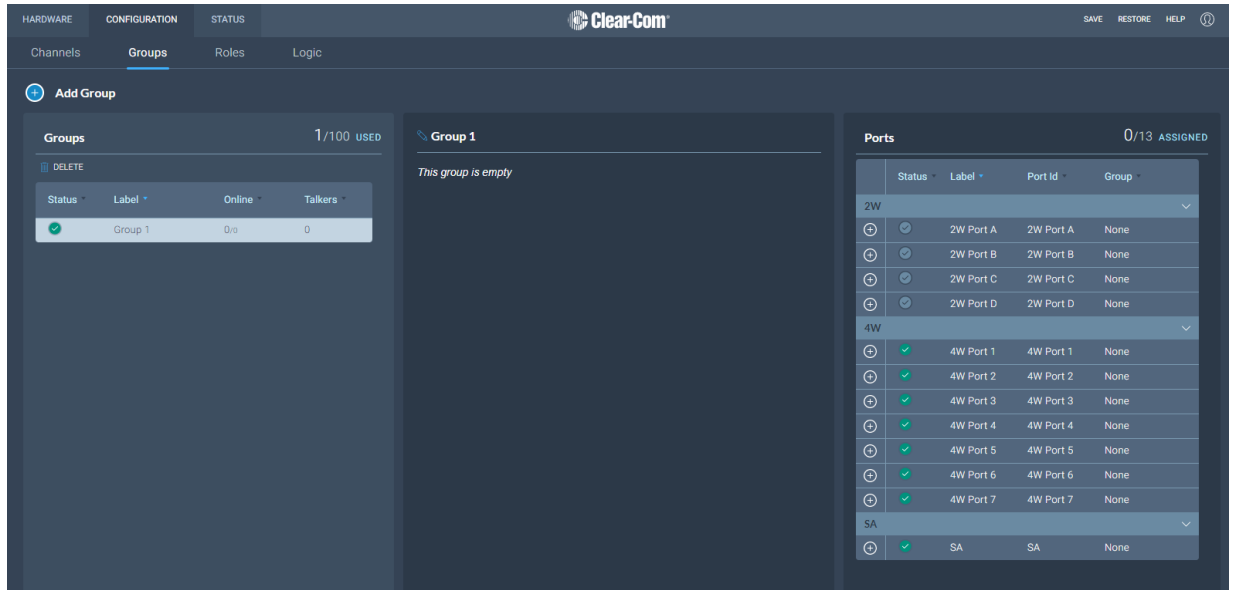

The Groups Page allows you to view Groups and add ports to Groups. Roles are added to Groups in the **Roles** page.

5.15.1 Managing Groups

From the **Groups** tab, you can:

- View existing groups and add or remove new groups.
- View existing ports, and add or remove ports from the groups.

Note: *Belpacks are added to Groups in the Roles page.*

To access the **Groups** screen, navigate to **Configuration > Groups**. The Groups screen appears:

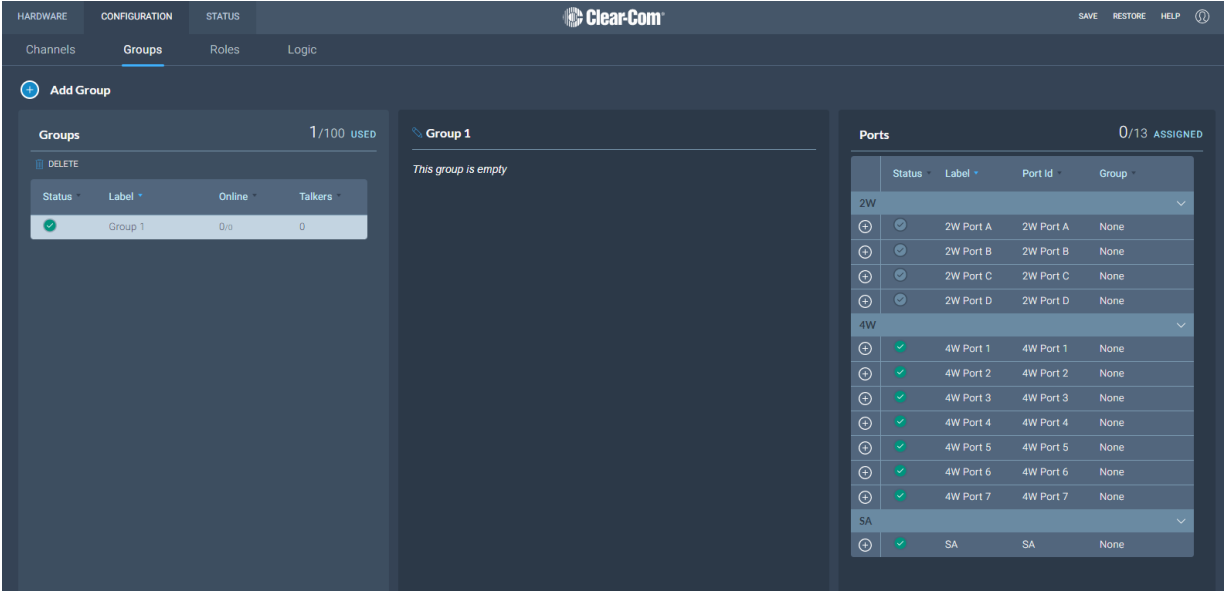

Viewing Information About a Group

When you open the **Groups** screen, the left-hand panel displays a list of all the groups that have been created. The following information is displayed for each group.

Click this icon to delete a group

The group count indicates that two out of a maximum of 100 groups are present

A green tick mark indicates that all configured ports are connected

This is a label for the group

This indicates how many users are talking on this group

This indicates how many configured ports are connected

Status

A green tick mark indicates that all the ports that are configured for group are connected. Otherwise, a warning triangle is shown.

Name

This field contains a label that enables you to identify the group.

Note: A label can contain up to 10 characters. You can edit this label from the center panel.

Online

This indicates how many of the total group members are online.

Talkers

This indicates how many FS II beltpacks or logic-routed ports have active talk routes on this group.

Adding a New Group

To add a new group:

1. Click the new group icon . A new entry appears in the list of added groups.

Note: You can only add new groups up to a maximum number (100).

2. You can now add any required ports and members to the group.

Adding Ports and Roles to a Group

To configure a group you must first put the members in the group. These can be ports and/or roles. When you have done this you will configure a talk key to the group (group administrator).

Adding Ports to a Group

1. From the **Group** panel, select the group in which the port is to be added.
2. From the **Ports** panel, click the add port icon  of the port that you require.

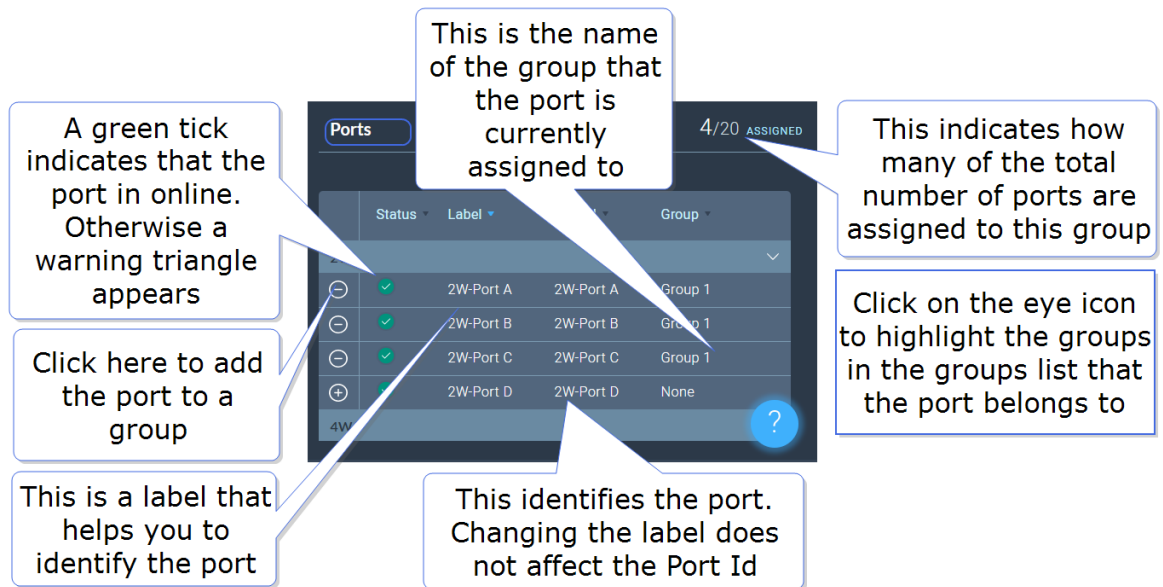

The port is now added to the group, and appears in the list of ports in the center panel.

Adding Roles to a Group

1. In the **Roles** page, select the role you wish to add to the group.
2. On the left side of the screen, select **Group Membership**.

Group Membership

Group Membership **Unassigned** 

Headset

Limiters **0 dB** 

Sidetone Gain **-12 dB** 

Sidetone Control **Tracking** **Non-Tracking** **Disabled**

Headphone Detect **Enabled** **Disabled**

Headset Mic Type **Dynamic** **Electret**

Note: A callout bubble points to the grid icon with the text "Add role to a group".

Configuring a Talk Key to the Group

1. In the **Roles** page, select the role you want to talk to the group.
2. Configure a talk key to the group (Talk Only)

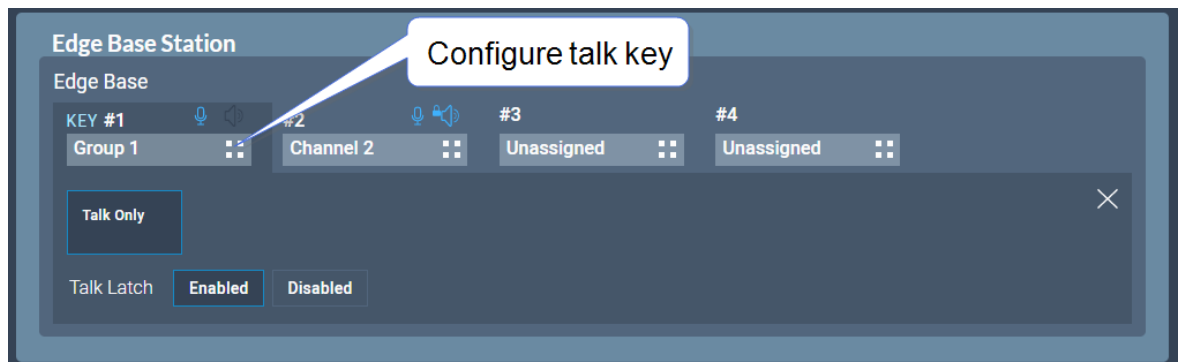

3.

When you have configured members and a talk key to a group, you will see the group by selecting it in the **Groups** page. The group administrator will talk to the whole group. The group members can talk directly back to the group administrator using the **Reply** key. This communication will not be broadcast to the group, only the administrator will hear.

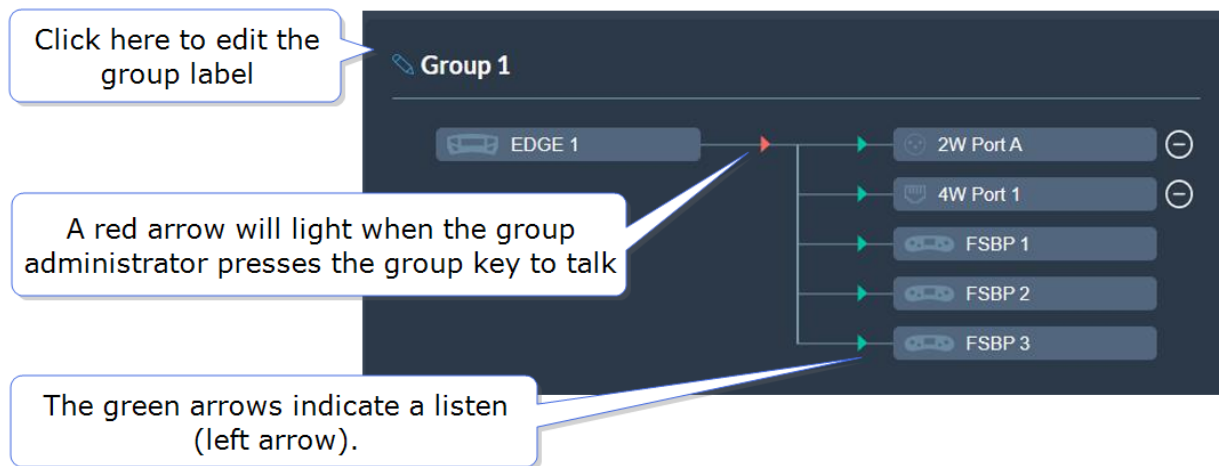

Removing Ports from a Group

To remove a port from a group:

1. From the **Groups** panel, select the required group.

2. Click the remove icon  of the port that you want to remove.

The port is removed.

Deleting a Group

To delete a group:

1. From the **Groups** panel, select the group that you want to delete.
2. Remove all the ports from the group

Note: *If you do not remove the ports, you will be prompted to do so in step 3.*

3. Click the trash can icon. The group is deleted.

5.16 Roles Page

The **Roles** page enables you to create roles for the devices in your intercom system.

Roles are made for:

- The Arcadia
- FreeSpeak II beltpacks
- FreeSpeak Edge beltpacks
- HelixNet beltpacks
- HelixNet remote stations
- HelixNet speaker stations

A role can be made that can be used with either an FS II beltpack or an FS Edge beltpack (this role can only be used on one beltpack at any one time).

Note: *FreeSpeak roles work on a 1:1 basis, each beltpack must have a unique role. HelixNet roles work on a 1: many basis, a HelixNet role can be used by many user stations. .*

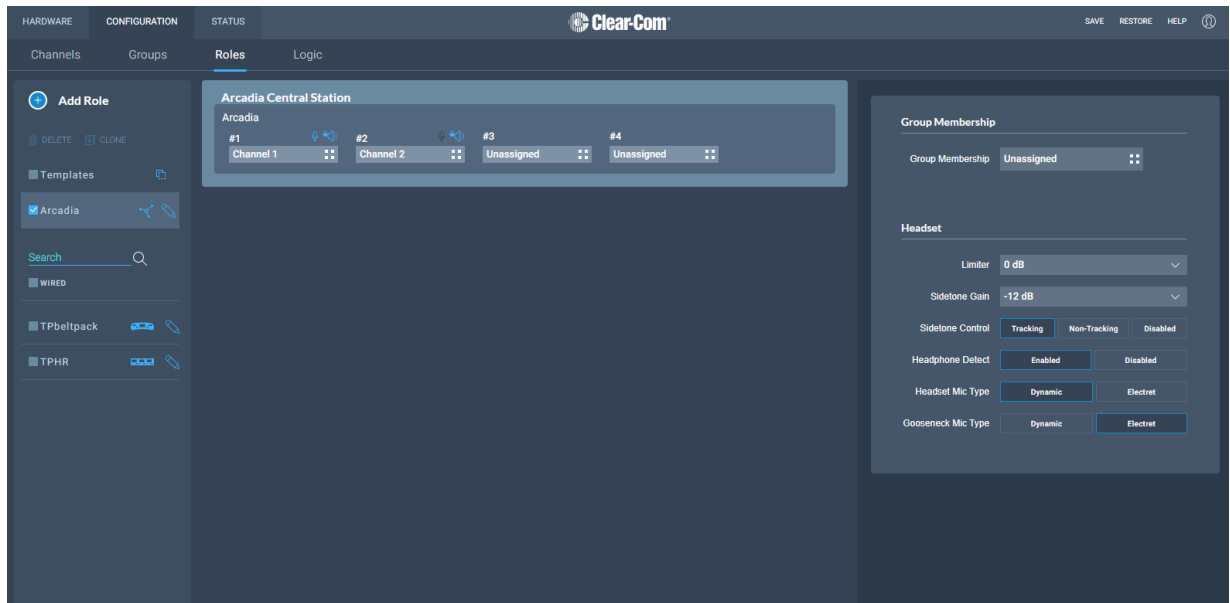

The **Roles** page of the CCM enables you to:

- View, edit, add and delete roles.

5.16.1 Managing Roles

Roles are used to control the audio configuration and other settings for beltpacks and other devices.

From the **Roles** page, you can view, add, edit, clone or delete roles.

When creating roles, roles can be:

- Added (role is based on the template role)
- Cloned (role is based on any selected role)

When working with FreeSpeak II, a role must be created for each beltpack or device that you use. This relationship is 1:1. If you want the same settings for multiple beltpacks, you may decide to clone an existing role.

When working with HelixNet, a role can be used many times. This relationship is 1:many. In HelixNet, roles are available for: beltpacks, remote stations, speaker stations.

Viewing Roles

To view roles, navigate to **Configuration > Roles**. The following screen appears.

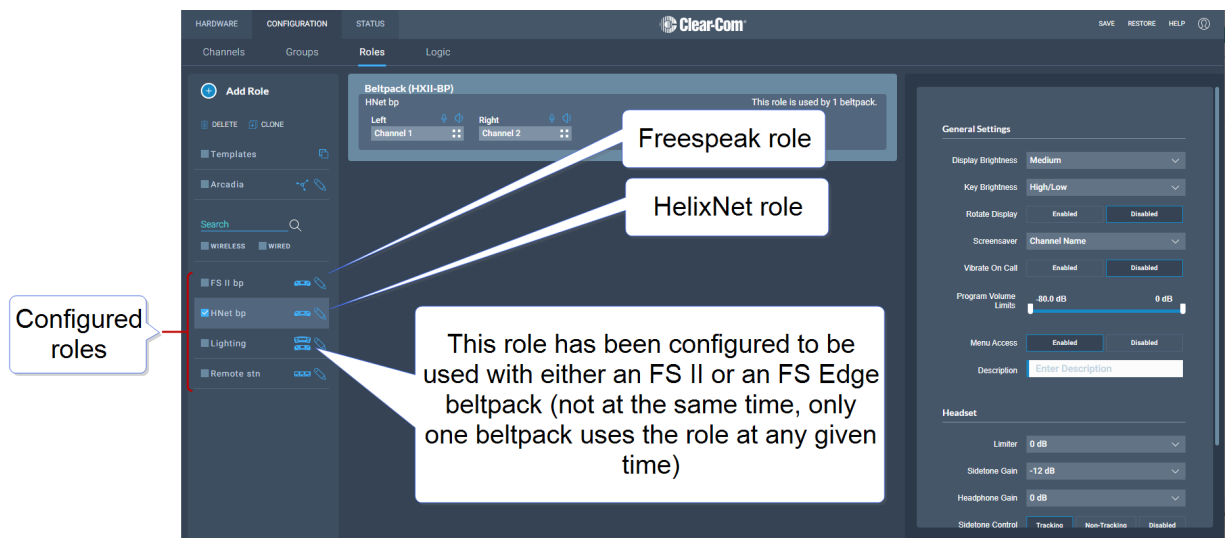

A list of roles appears on the left-hand side of the screen.

Role Templates

When you add roles, a new role is always created from a template role. Template roles are editable. If you edit a template role, any new roles created from it have the edited settings.

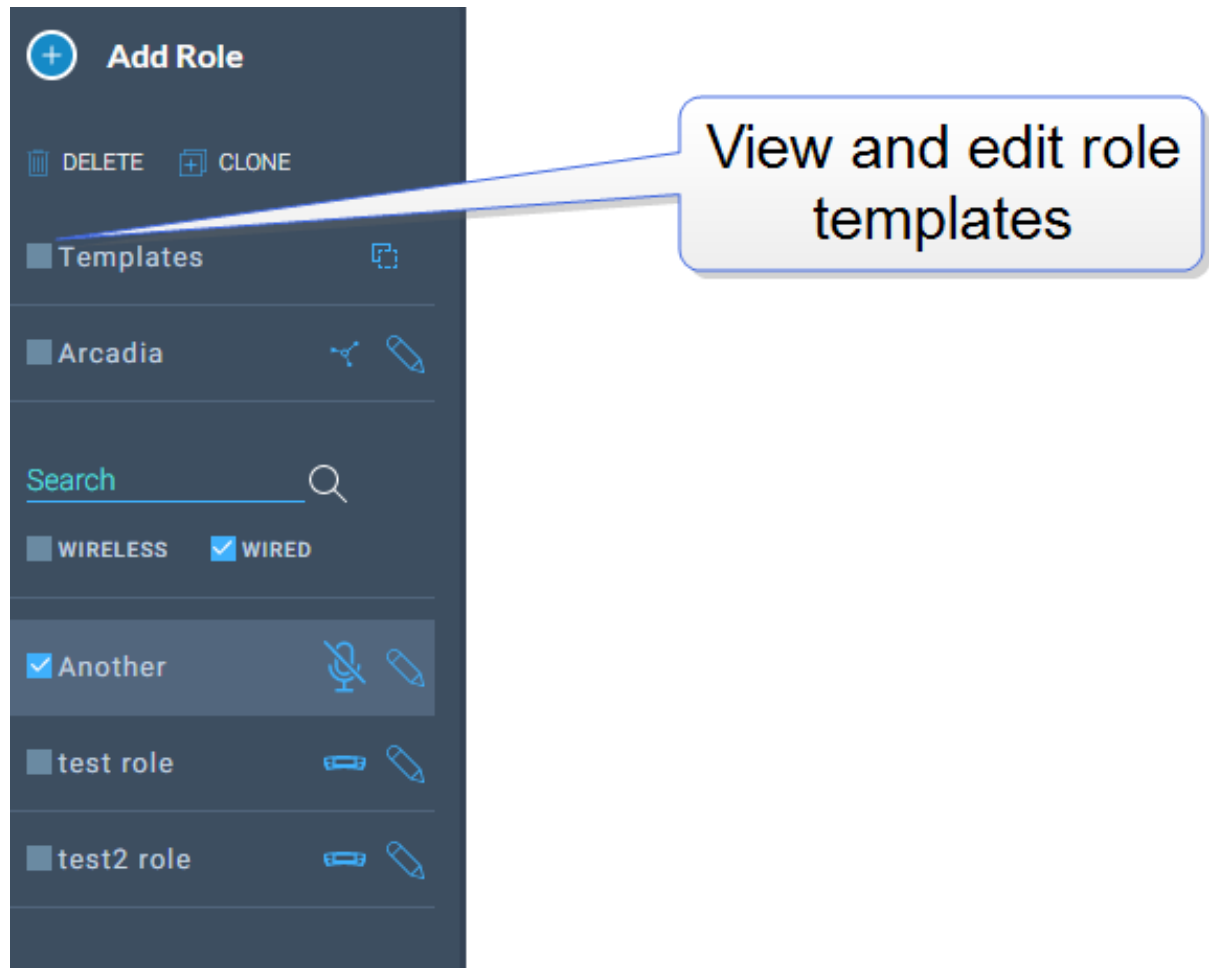

Select a role template to edit the settings.

To reset template roles to default settings, reset the Arcadia to factory defaults.

Note: *The role templates you see depend on which feature licenses you have on the Arcadia.*

Adding Roles

To add roles:

1. Navigate to **Configuration > Roles**.

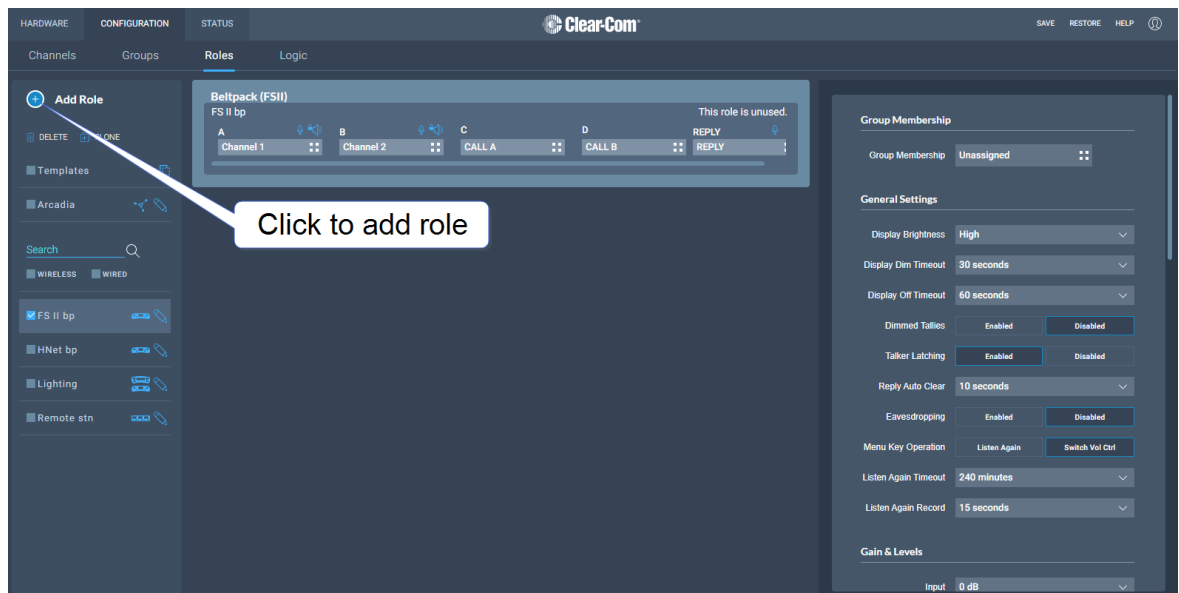

2. Click **Add Roles**. The following screen appears.

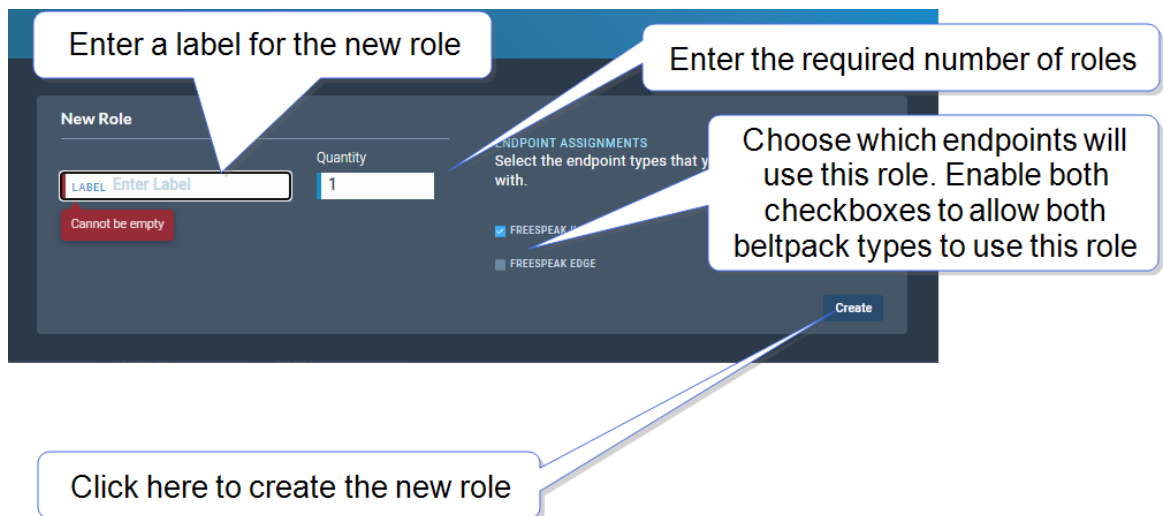

3. Enter a label for the role, the number of roles required and choose which endpoints will use this role (FS II, FS Edge or both). Only one beltpack can use the role at a given time.

Note: When creating multiple roles, the system will add an incrementing numerical suffix to the role name. Roles names must be unique.

Note: You can also edit the label and endpoint assignments from the icons that appear

beside each role in the left-hand side of the screen.



4. Click **Create**. The new role appears in the list of roles in the left-hand side of the **Roles** screen.

Editing Role Key Assignment

1. Navigate to **Configuration > Roles** and select required role on the left of the screen.
2. Click on the small white squares.

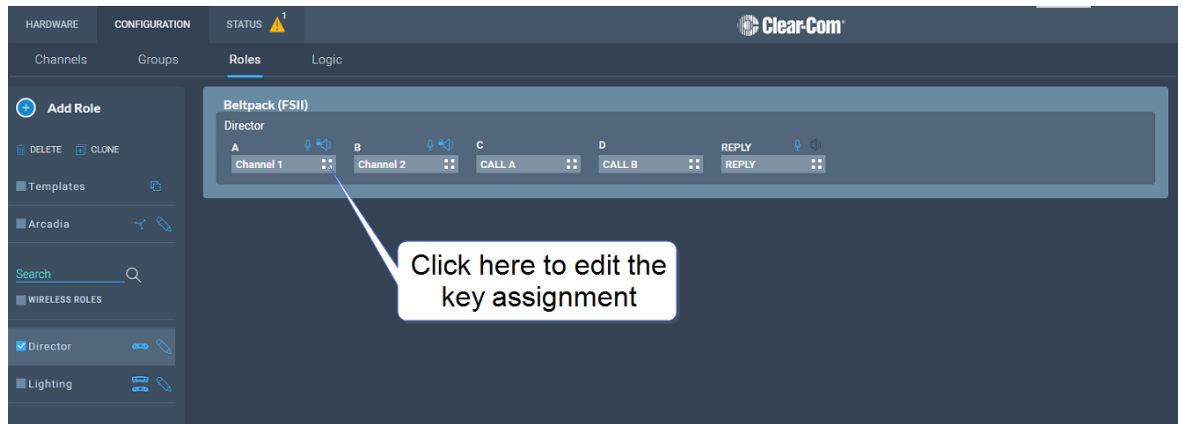

The key assignment screen appears.

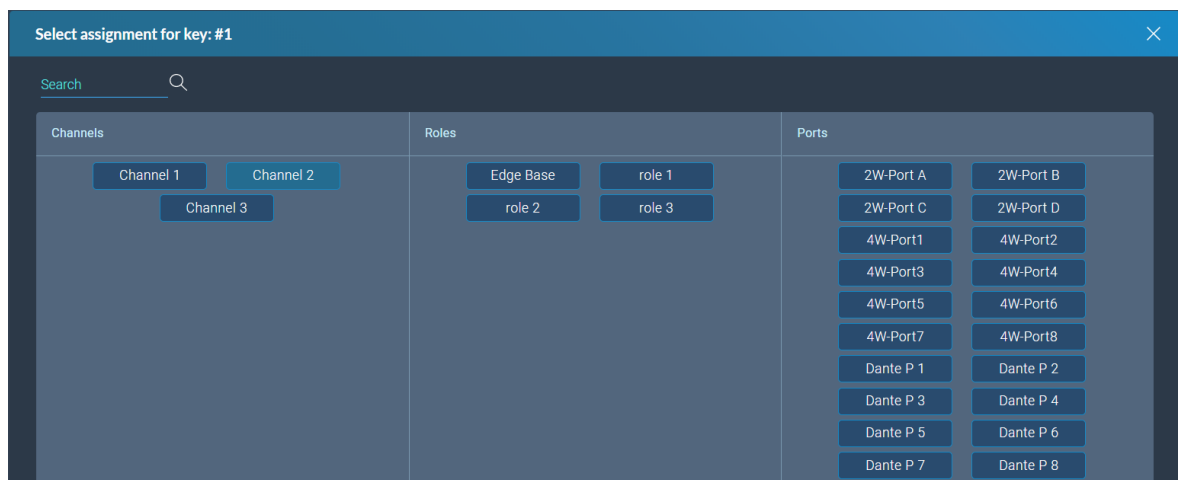

3. Click to select the required audio source.

Configuring Role Settings

To configure the settings for a role:

1. Navigate to **Configuration > Roles**, and select the required role from the list of roles in the left-hand side of the screen.
2. From the **Settings** panel on the right-hand side of the screen, scroll to the required setting.
3. Edit the setting as required.

Cloning Roles

To clone roles:

1. Navigate to **Configuration > Roles**, and select the role that you wish to clone from the list of roles in the left-hand side of the screen.
2. Click **CLONE**.

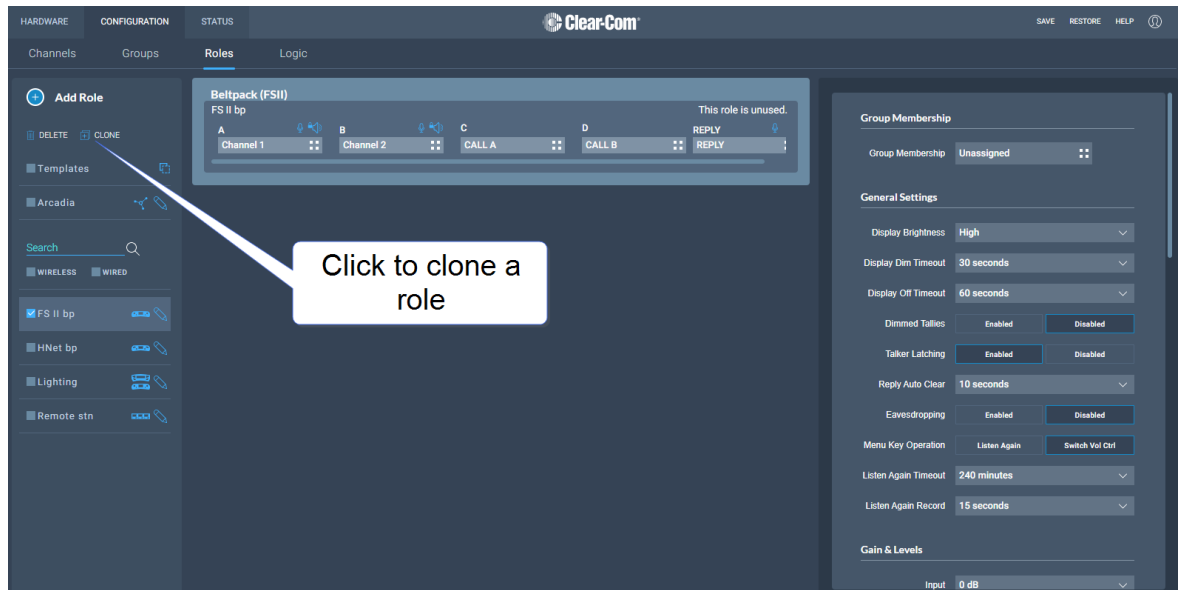

The role is cloned and added to the list of roles in the left-hand side of the screen.

Deleting Roles

To delete roles:

1. Navigate to **Configuration > Roles**, and select the role that you wish to delete from the list of roles in the left-hand side of the screen.
2. Click **DELETE**.

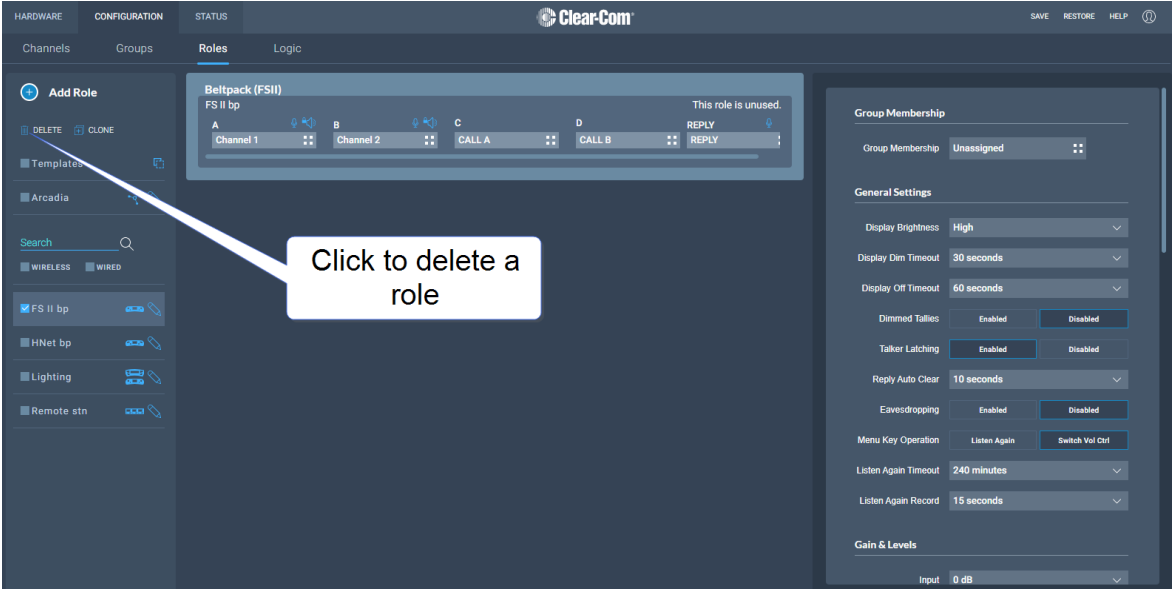

The role is deleted and removed from the list of roles in the left-hand side of the screen.

Setting Key Behavior

Audio keys can be set to different Talk and Listen states. These key behavior states apply to the keys on the Arcadia and beltpacks. Key behavior is configured in the **Roles** tab in the CCM. See [Managing Roles on page 84](#).

| Key Behavior Options | Resulting Audio Behavior |
|--|---|
| Talk-Only | Press key to talk. Key only controls talk. |
| Listen-Only | Press key to listen. Key only controls listen. |
| Talk and Listen | <p>FreeSpeak: Press single key to talk and listen.</p> <p>Arcadia: Press listen or talk separately.</p> <p>HelixNet Remote/Speaker Station: Press listen or talk separately.</p> |
| Dual Talk and Listen (FreeSpeak only) | Press key to talk and listen. Listen latches on or off according to preference (quick tap to latch). The user can push and hold (PTT) to activate talk. |
| Force Listen | Permanent listen. |
| Talk and Forced Listen | Permanent listen, push key to talk. |
| Force Talk and Force Listen (FreeSpeak and HelixNet) | Permanent listen and talk. |

Fixed Roles

When a role is fixed to a beltpack, a beltpack user is forced to use that role. If a role is not fixed to a beltpack, the user can chose from any available roles.

When you register beltpacks via USB cable to the Station, an editable fixed role is created and applied to the beltpack.

Roles can be fixed/unfixed in the CCM.

Navigate to: **Hardware > Resources > Endpoints** (select the down arrow to see all connected Endpoints). Select an Endpoint (beltpack) by clicking it. Click to fix/unfix or change the role for this beltpack.

The screenshot shows the Clear-Com software interface for managing resources on a host. The main window is titled 'Resources' and displays a list of endpoints under the 'Endpoints' section. A callout box labeled 'Select beltpack' points to the 'HXII-BP_c29302' entry in the table. A second callout box labeled 'Role' points to the 'TPbeltpack' role assigned to that entry. A third callout box labeled 'Unpair or deregister beltpack' points to the 'Unpair' button in the 'Maintenance' section of the right-hand panel.

| Status | Label | ID | Role | Type |
|--------|----------------|--------|--------------|--------|
| 🔄 | HXII-BP_5db302 | 5DB302 | Local Config | HBP-2X |
| ✅ | HXII-BP_c29302 | C29302 | TPbeltpack | HBP-2X |

Host Details:
NAME: f080925
TYPE: Arcadia Central Station
IP ADDRESS: 10.50.16.25
CONNECTIONS: 2W 4W DANTE | FSE FSII HELIXNET
LICENSED PORTS: 96
VERSION NUMBER: 2.3.83.18
POWER STATUS: 🟡 🟡 🟢

Endpoints Summary: 1/2 ONLINE

Physical Ports Summary: 9/13 ONLINE

Dante Ports Summary: 0/0 ONLINE

Licensed Ports Summary: 4/96 IN USE

Right Panel (HXII-BP_c29302):
General: Type HBP-2X, ID C29302, Select Role TPbeltpack
Version: 4.2.68.0
Maintenance: Unpair this endpoint from the station to free up any assigned resources preventing automatic reconnection. [Unpair]

5.17 Logic Page

The Arcadia Logic module facilitates external control and conditional configuration.

GPI: Hardware on Arcadia and virtual via I.V. Direct can be configured to control up to 10 audio crosspoints / call signals.

These can be used for:

- Footswitches controlling audio
- Automating Program Audio routing
- Call signaling
- 2-Way Radio Input Routing

GPO: Hardware on Arcadia and virtual via I.V. Direct can be configured to activated from up to 10 audio crosspoints/call signals.

These can be used for:

- Call signaling
- On-Air or warning signals
- 2-Way Radio Transmit Trigger

The **Control Logic** section facilitates conditional (if->then) logic using audio crosspoints, call signals and GPIO.

Hardware GPIO and I.V. Direct virtual GPIO are configured in the **Configuration > Logic** page of the Core Configuration Manager (CCM) and can be viewed and tested on the **Status > Logic** page.

The screenshot displays the 'Logic' configuration page in the Clear-Com interface. It features a dark-themed layout with a top navigation bar containing 'HARDWARE', 'CONFIGURATION', and 'STATUS' tabs. The 'CONFIGURATION' tab is active, and the 'Logic' sub-tab is selected. The main content area is divided into three sections:

- GPIO:** A table with columns 'Status' and 'Name'. It lists GPI1 and GPI2 under the 'GPI' category, and GPO1, GPO2, GPO3, and GPO4 under the 'GPO' category.
- GPI1:** A section titled 'Crosspoints Events' with a message: 'No crosspoints have been configured for this GPI'.
- Control Logic:** A section with a message: 'No logic events have been configured'.

Additional UI elements include a 'Clear-Com' logo and 'SAVE', 'RESTORE', and 'HELP' buttons in the top right, a '0/10 USED' indicator, and a help icon in the bottom right corner.

5.17.1 Setting up GPIOs and Control Logic Events

- 2 x GPIs
- 4 x GPOs
- Unlimited Control Logic Events
- Each GPI/GPO hosts up to 10 different events or actions. These actions can be overridden for testing or to bypass the logic in the **Status > Logic** page of the CCM.
- 2 x DB 9F connectors on the rear of the Arcadia .
- For DB 9F pinouts, see [Appendix A: Pinouts on page 180](#)

Examples of GPIs

On an input from an external device, an audio route can be established.

- If an on-air light comes on, the program feed (**PGM**) can be routed to a Channel or beltpack.
- Use a footswitch to allow the station user to open an audio route to a Channel.
- On an input from a two-way radio, an audio route can be established to a channel (the radio talks to the channel).

Examples of GPOs

GPOs are triggered (sent to an external device) when a **Talk**, **Talk & Listen** or a **Call** comes into a named entity.

- When someone talks to stage announce, an output relay (GPO) is sent to the external stage announce speaker.
- When someone talks to a channel labeled Radio, an output is sent to a 2-way radio.
- When a call signal (**Call**) comes into a channel, and output is sent to turn on an on-air light.

Examples of Control Logic Events

- An output can be triggered on a crosspoint activation (when someone presses a talk key).
- An input can be used to trigger a call signal.

Configuring GPIs

This example opens a talk route from the Arcadia to a Channel when an input occurs on GPI1 (for instance, from a footswitch).

Navigate to **Configuration > Logic**.

1. On the left panel, click GPI1 to select it.

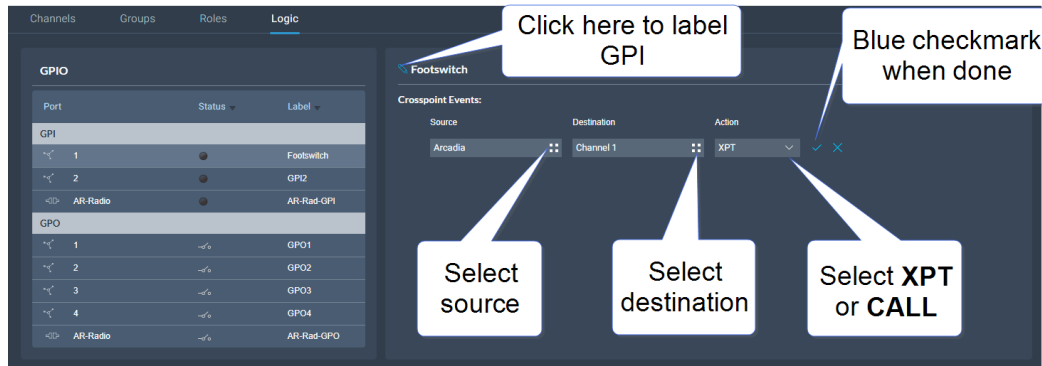

2. Click the Add button  in the center panel.

3. Click the Options button  to select a **Source**. Select **Arcadia**

4. Click the Options button  to select a **Destination**. Select the required Channel.

5. Select **Action** (crosspoint or call signal). In this case choose crosspoint (**XPT**).

6. Click the blue check mark.

7. To label the GPI, click the pencil icon.

8. To test the GPI, or turn it on and off, navigate to **Status > Logic**. See: [Logic Page on page 93](#).

Configuring GPOs

In this example you send an output trigger (for example to an external stage announce speaker) on GPO1 when a beltpack **Talk** is activated on the stage announce (**SA**) 4-wire port.

1. Navigate to **Configuration > Logic**.



2. On the left panel, click GPO1 to select it.

3. Click the Add button  in the center panel.

4. Click the Options button  to select a **Key Target**. Select stage announce (SA).

5. In this case, the **On Behavior** field defaults to **Talk Only**.

6. Click the blue check mark.

7. To label the GPO, click the pencil icon.

8. To test the GPO, navigate to **Status > Logic**. See [Logic Page on page 93](#).

Note: *GPO **Talk & Listen** behavior is only for use with FreeSpeak (**Talk & Listen** or **Dual Talk & Listen**) key activations on a single button. **Talk-Only** is for use with Arcadia, FreeSpeak and HelixNet keys using all other types of Talk activations.*

5.18 Status Page Overview

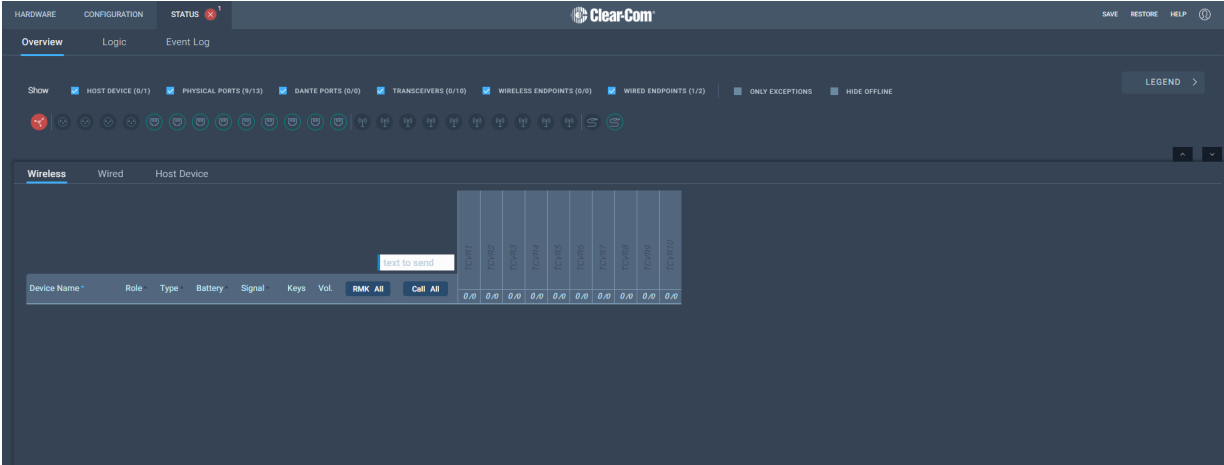

From the **Status** page of the CCM, you can view the status of all the resources that are connected to the Arcadia Central Station. These include:

- Transceivers (IP and E1)
- Beltpacks
- Interface ports

Here you will see error and warning states.

Note: *Error states are used exclusively to indicate that audio via this resource is not working.*

You can quickly see if entities are:

- Offline
- Online
- Initializing

5.18.1 Monitoring System Status

You can monitor your system using the following features of the CCM:

- Overview
- Event Log
- Logic

Overview

To see the **Overview** screen, navigate to **Status > Overview**. The following screen appears.

The **Overview** screen consists to two sections. There is an upper section that displays a list of system icons representing the ports, transceivers and endpoints and a lower section that gives detailed information about each connected device and about the Arcadia.

Note: *There is currently no detailed status for 2W, 4W and Dante.*

System Icons

Each icon is color-coded to give an easily accessible view of the status of each entity.

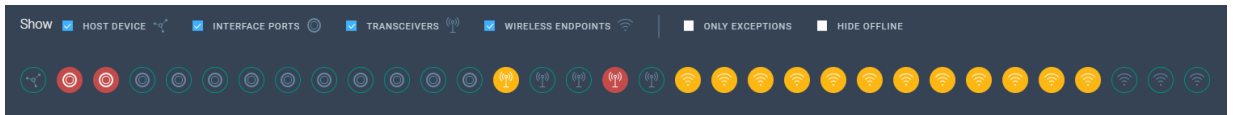

The following legend is used to indicate the status of each entity.

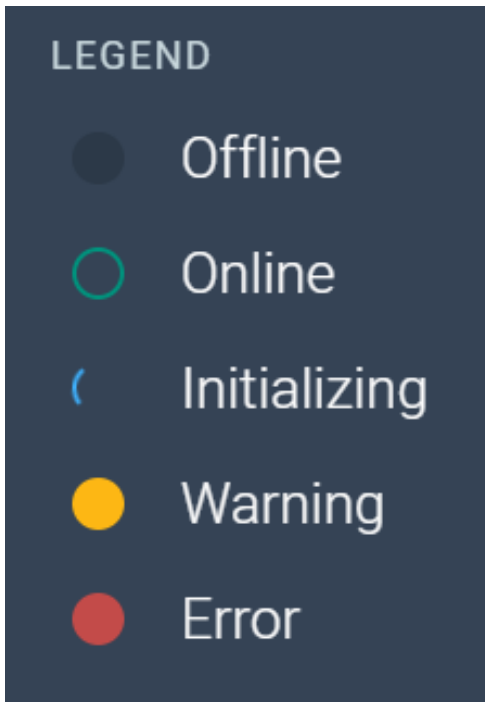

Monitoring Wireless Devices

Navigate to **Status > Overview > Wireless**. This section of the **Overview** screen lists all the wireless devices connected to your system, and gives the following information for each device:

- Associated role
- Type of transceiver
- Battery level
- Signal strength
- Volume setting
- Remote Microphone Kill (RMK) button to mute all microphones connected to your system
- Call button to send a text message to all connected beltacks
- Network and PTP status of transceivers

Wireless Wired Host Device

text to send

| Device Name * | Role | Type | Battery | Signal | Keys | Vol. | RMK All | Call All | TCVR1 | TCVR2 | TCVR3 | TCVR4 | TCVR5 | TCVR6 | TCVR7 | TCVR8 | TCVR9 | TCVR10 | CC-TCVR-08XYF386 | CC-TCVR-08XYF396 | CC-TCVR-32XY0085 | CC-TCVR-32XY0478 | CC-TCVR-32XY0108 | CC-EDGE-26XYF751 | CC-EDGE-07304803 |
|----------------|----------|----------|---------|--------|------|------|---------|----------|-------|-------|-------|-------|-------|-------|-------|-------|-------|--------|------------------|------------------|------------------|------------------|------------------|------------------|------------------|
| EDGE-BP-524403 | Producer | FSE 5.0 | | | | | RMK | Call | 0/0 | 0/4 | 0/4 | 0/0 | 0/0 | 2/4 | 0/4 | 0/4 | 0/0 | 0/0 | 0/10 | 0/0 | 0/10 | 1/10 | 2/10 | 2/10 | 0/10 |
| EDGE-BP-524481 | Actor | FSE 5.0 | | | | | RMK | Call | | | | | | | | | | | | | | | | | |
| FSII-BP-16210 | Ademola | FSII 1.9 | | | | | RMK | Call | | | | | | | | | | | | | | | | | |
| FSII-BP-16226 | Lara | FSII 1.9 | | | | | RMK | Call | | | | | | | | | | | | | | | | | |
| FSII-BP-28036 | Katty | FSII 1.9 | | | | | RMK | Call | | | | | | | | | | | | | | | | | |
| FSII-BP-327796 | Dancer | FSII 2.4 | | | | | RMK | Call | | | | | | | | | | | | | | | | | |
| FSII-BP-327814 | Singer | FSII 2.4 | | | | | RMK | Call | | | | | | | | | | | | | | | | | |

Transceiver details

HARDWARE CONFIGURATION STATUS Clear-Com SAVE RESTORE HELP

Overview Event Log Logic

Show HOST DEVICE (1/1) PHYSICAL PORTS (9/13) DANTE PORTS (0/9) TRANSCIEVERS (2/12) WIRELESS ENDPOINTS (4/4) ONLY EXCEPTIONS HIDE OFFLINE

View details

Wireless Wired Host Device

text to send

| Device Name * | Role | Type | Battery | Signal | Keys | Vol. | RMK All | Call All | TCVR1 | TCVR2 | TCVR3 | TCVR4 | TCVR5 | TCVR6 | TCVR7 | TCVR8 | TCVR9 | TCVR10 | CC-EDGE-37260794 | CC-TCVR-08XYF426 |
|----------------|--------|----------|---------|--------|------|------|---------|----------|-------|-------|-------|-------|-------|-------|-------|-------|-------|--------|------------------|------------------|
| EDGE-BP-524291 | EDGE 1 | FSE 5.0 | | | | | RMK | Call | 0/0 | 0/0 | 0/0 | 0/0 | 0/0 | 0/0 | 0/0 | 0/0 | 0/0 | 0/0 | 2/10 | |
| EDGE-BP-524338 | EDGE 2 | FSE 5.0 | | | | | RMK | Call | | | | | | | | | | | | |
| FSII-BP-15901 | FSBP 2 | FSII 1.9 | | | | | RMK | Call | | | | | | | | | | | | |
| FSII-BP-16231 | FSBP 1 | FSII 1.9 | | | | | RMK | Call | | | | | | | | | | | | |

Select a transceiver to see network, version and PTP details.

PTP details

CC-TCVR-08XYF426

Network

AE367 Admin IP Address 169.254.8.123

AE367 Audio IP Address 169.254.8.128

Subnet Mask 255.255.0.0

Network Mode DHCP

Version

Version 4.8.67.0

Radio Version 0107

FPGA Version v.0.6.2-846v2.3.4-b100-c2

PTP

Status Locked

Role Slave

Master ID 00-0e-98-ff-fe-08-02-3a (Priority 127)

Local ID 00-0e-98-ff-fe-02-fe-77 (Priority 254)

Offset from Master 20 ms (max 47 ms)

Mean Path Delay 6,600 ns +/- 3

Mean Frequency -1 ppb +/- 27

Maintenance

Monitoring Beltpack Details

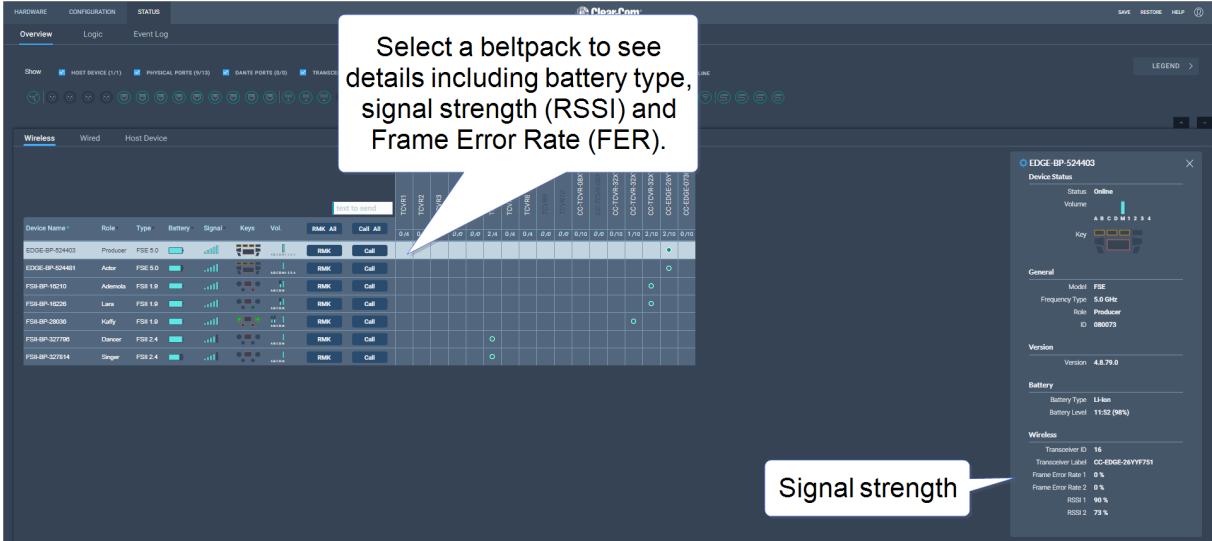

Monitoring Wired Devices

Navigate to **Status > Overview > Wired**. This section of the **Overview** screen lists all the wired the HelixNet user stations (beltpacks, remote stations and speaker stations) in your system. It also shows the connection method, Ethernet or Powerline Device. Click on a device for information and network stats.

Click on the cog icon  for configuration and procedures: reboot, unpair and reset to default.

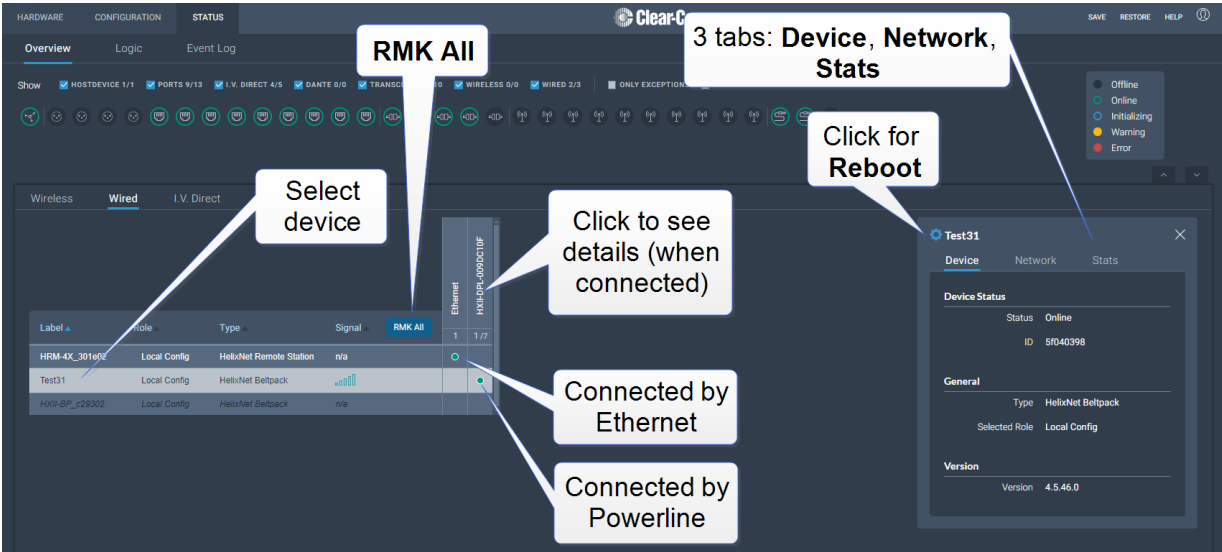

Monitoring I.V. Direct

Navigate to **Status > Overview > I.V. Direct**. This section of the **Overview** screen lists all the I.V. Direct ports connected to your system, and gives the following information for each device:

Interface

- Status (online/offline)
- User ID
- GPI
- GPO

Click the cog  icon to configure GPIOs

Network

- Local IP address
- Local port
- Remote IP address (if this is the calling device)
- Network quality (LAN, WAN or Internet)

Click the cog  icon to configure settings and credentials

Diagnostic information

- Connection time
- Average jitter
- Max jitter
- Rx packets
- Tx packets
- Rx drops

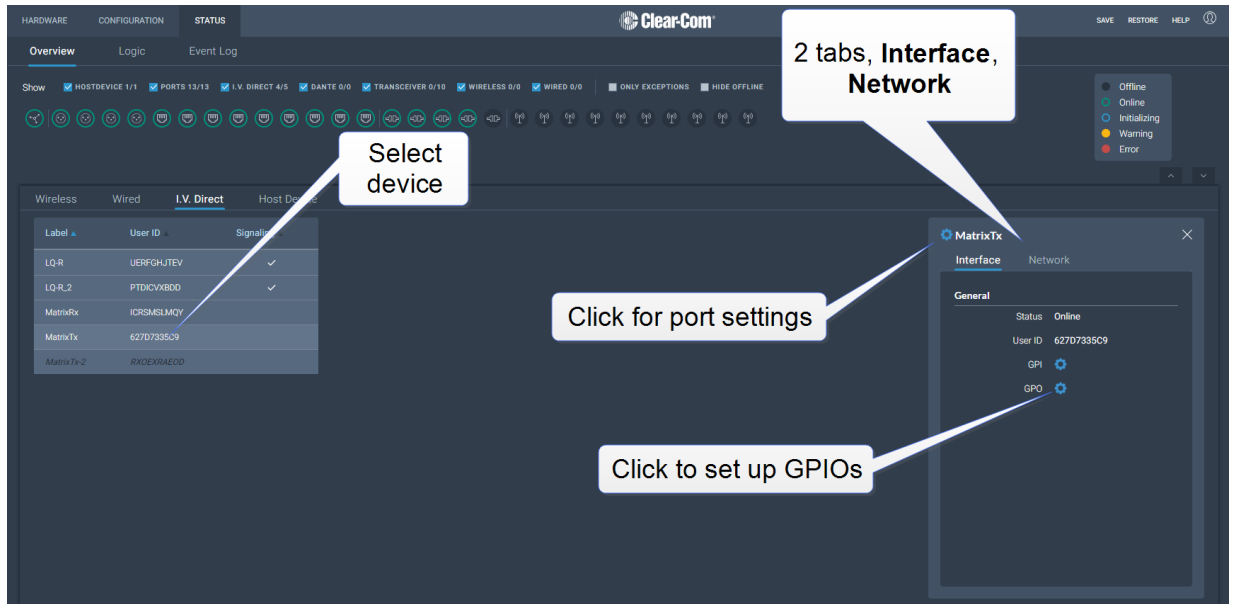

Monitoring the Host Device

Navigate to **Status > Overview > Host Device**. A screen appears that gives information about the Arcadia and enables various procedures including:

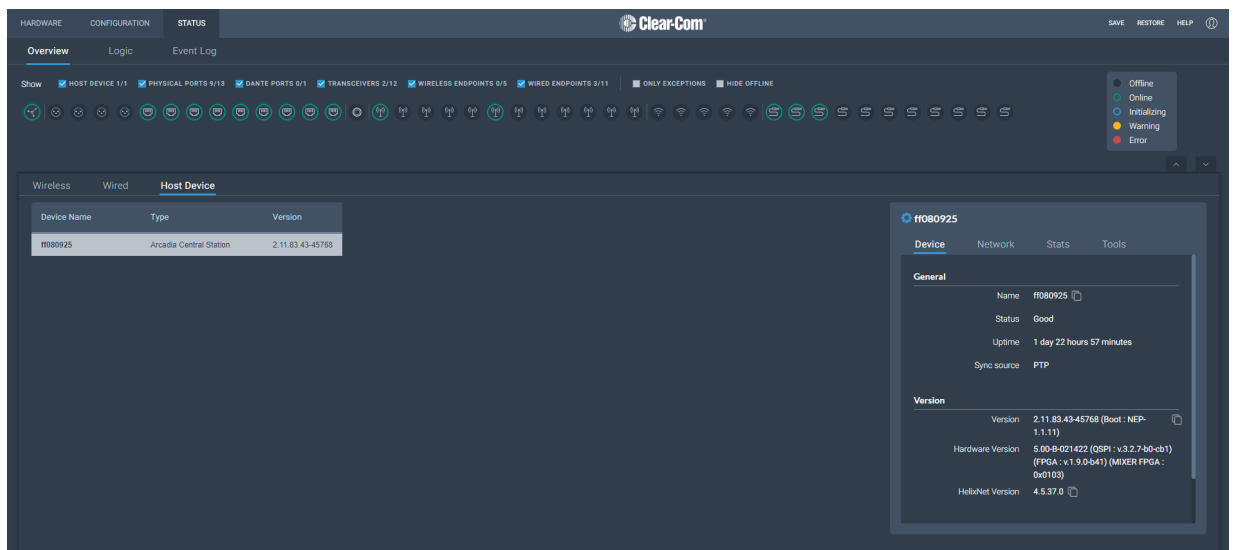

5.18.2 Monitoring the Event Log

The Event Log provides useful information about events that happen in the system.

The Event Log can be filtered on:

- Time: default is 1 month prior to the current date and time
- Exceptions (warnings and errors): default is unchecked.

Events are sorted by data. Clicking the small blue arrow changes date order:

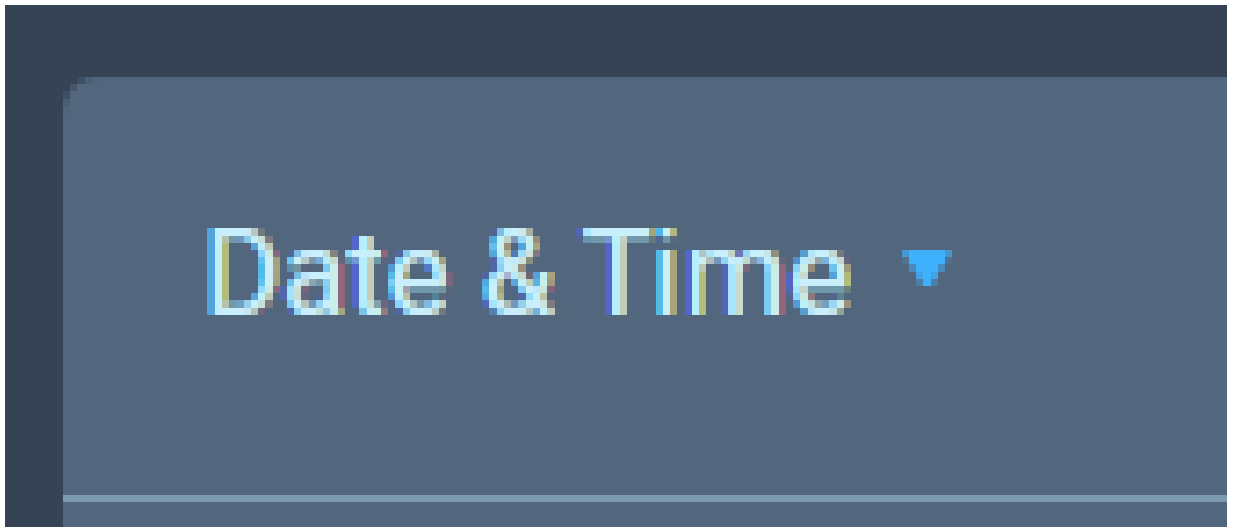

The **Level** column shows the status of data:

- Yellow triangle: warning
- Red circle with white cross: error
- No icon shown: this data is informational.

The following apply to the Event Log:

- The Event Log periodically refreshes but there is a **Refresh** button to pull the latest events
- The Event Log can be exported to a .csv file
- **Clear Event Log** clears current data. The data cannot be retrieved once it has been cleared
- Event logs are not stored permanently, only events since the last power or reboot cycle are available.

5.18.3 Monitoring the Logic Page (Status)

This page shows the GPIs and GPOs (relay) that you have set up in the **Configuration > Logic** page. You can see if these are currently active in the system under the **Status** column.

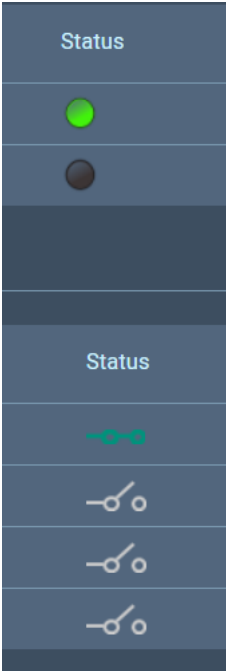

A green icon indicates a currently active input or relay.

Forcing ON/OFF

The buttons under the FORCE column are toggle buttons that can be used to test the working of the GPIOs or to turn them permanently off or on. These override the operation of the configured GPIOs.

| Logic Inputs | | | | | |
|--------------|-----------|--------------------|--------------------|--------|--|
| | GPI Label | Route Source | Route Destination | Status | Force |
| 1 | GPI1 | No events assigned | No events assigned | | <input type="button" value="OFF"/> <input type="button" value="ON"/> |
| 2 | GPI2 | No events assigned | No events assigned | | <input type="button" value="OFF"/> <input type="button" value="ON"/> |

| Logic Outputs | | | | | |
|---------------|-----------|----------------------|----------------------|--------|--|
| | GPO Label | Key Target | On Behavior | Status | Force |
| 1 | GPO1 | No triggers assigned | No triggers assigned | | <input type="button" value="OFF"/> <input type="button" value="ON"/> |
| 2 | GPO2 | No triggers assigned | No triggers assigned | | <input type="button" value="OFF"/> <input type="button" value="ON"/> |
| 3 | GPO3 | No triggers assigned | No triggers assigned | | <input type="button" value="OFF"/> <input type="button" value="ON"/> |

In this example, GPI 1 and GPO 2 are forced ON for testing purposes. GPO 2 is permanently OFF (for example, if you want to ensure that a signal light never comes on at this time).

6 Using FreeSpeak Wireless Intercom

This chapter describes how to connect to E1 and IP transceivers. It contains the following sections:

- 6.1 Overview of Transceivers 107
- 6.2 Connecting Transceivers Over E1 107
- 6.3 Adding IP Transceivers 112
- 6.4 Network Setup for IP Transceivers 113
- 6.5 Registering FreeSpeak Beltpacks 117
- 6.6 FS Edge Transceivers 120

6.1 Overview of Transceivers



6.2 Connecting Transceivers Over E1

E1 is a telecommunications standard whereby data and power are sent over Cat 5/6 or Fiber cable. E1 connections must have dedicated cabling as it is not possible to use network switches with this technology.

FreeSpeak II systems (1.9 and 2.4 GHz) can be connected to the Arcadia using E1 connectivity.

Note: You must **not** place E1 1.9 GHz and IP 1.9 GHz transceivers from the same system in the same RF zone.

Transceivers can be connected directly to the Arcadia (up to two transceivers) or connected using FreeSpeak II splitters (up to 2 splitters, each hosting up to 5 transceivers so up to 10 transceivers in total).

Transceivers/splitters are connected to the Arcadia using connectors G and H. See [Rear Panel Connectors and Indicators on page 30](#)

Note: FreeSpeak II splitters can be connected using Fiber or Cat 5/6 cable. Configure the port in: **CCM > Host > Wireless > Wireless Transceivers** (default = RJ45).

Example connection with a splitter



Note: The splitter connections are switched between RJ45 and Fiber routing using DIP switches inside the splitter.

For more examples of connection options and how to set the DIP switches, see the FreeSpeak II Splitter Quick Start Guide available from the [FreeSpeak II Knowledge Center](#).

6.2.1 Cable Distances - E1 Connections

| Arcadia to TCVR/splitter | |
|--|--|
| TCVR directly connected to and powered by the Arcadia | <ul style="list-style-type: none"> • 328 ft (100 m) using shielded 24 AWG Cat 5/6e cable • 164 ft (50 m) using shielded 26 AWG Cat 5/6e cable |
| TCVR directly connected to the Arcadia with local/direct power at TCVR | <ul style="list-style-type: none"> • 2625 ft (800 m) using shielded 24 AWG Cat 5/6e cable • 1312 ft (400 m) using shielded 26 AWG Cat 5/6e cable |
| Arcadia to splitter (splitter is locally powered) | <ul style="list-style-type: none"> • 2625 ft (800 m) using shielded 24 AWG Cat 5/6e cable • 1312 ft (400 m) using shielded 26 AWG Cat 5/6e cable |

| Splitter to TCVRs | |
|-------------------------------|--|
| TCVRs powered by splitter | <ul style="list-style-type: none"> • 328 ft (100 m) using shielded 24 AWG Cat 5/6e cable • 164 ft (50 m) using shielded 26 AWG Cat 5/6e cable |
| TCVRs have local/direct power | <ul style="list-style-type: none"> • 2625 ft (800 m) using shielded 24 AWG Cat 5/6e cable • 1312 ft (400 m) using shielded 26 AWG Cat 5/6e cable |

Note: *Fiber connections: connection distances will depend on existing cable infrastructure.*

6.2.2 Using a Transceiver With a Fiber Connection

To connect a Arcadia to a splitter (FSII-SPL) using Fiber, you must install Fiber modules to the Arcadia and the splitter.

- Modules are available for single mode Fiber cable (SFP-SMFO-100M-LX or HLI-SMFO) and multi-mode Fiber cable (SFP-MMFO-100M-FX or HLI-MMFO).
- Modules must be ordered from Clear-Com as a pair, one for the Arcadia and one for the splitter.
- Modules can be hot patched. There is no need to power off devices.
- To install the modules, simply remove the dust cap from the connector port and slide the module into the connector.

Note: *When using a Fiber connection, all devices must have local power supplied.*

6.2.3 E1 Transceiver/Splitter Port Connection Type (RJ45 or Fiber)

Transceivers/splitters can be connected to the Arcadia using either RJ45 cable or fiber cable. You can have two RJ45 connections, two Fiber connections or one RJ45 and one Fiber.

The connection type for the ports is determined by a software setting in the Core Configuration Manager (CCM). Default setting is **RJ45**.

Setting FSII Transceiver/Splitter Connection Type

1. In the CCM, navigate to **Hardware > Hosts > Wireless**.
2. Select **FreeSpeak II > Transceiver Port** type as required.

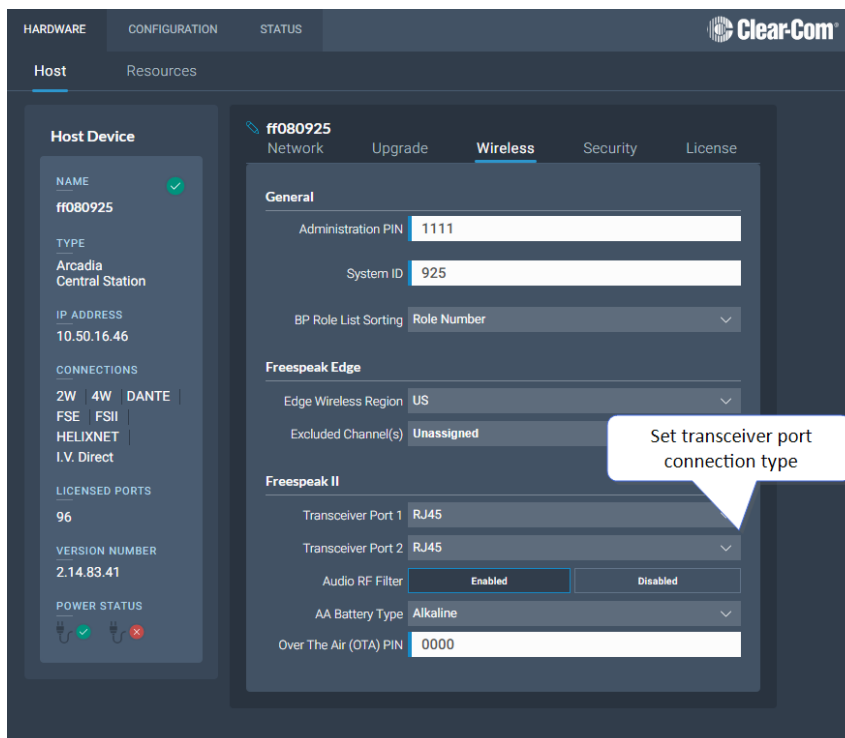

6.2.4 Audio RF Filter E1 Transceivers

An audio filter can be enabled or disabled for E1 1.9 GHz transceivers. This audio filter is designed to compensate for corrupted data in the wireless transmission. Default is **Enabled**.

To disable this setting, in the CCM go to: **Hardware > Host > Wireless > FreeSpeak II > Audio RF Filter**.

6.2.5 Setting Cable Length Offset (E1)

Cable length offset is used to optionally align the DECT or radio signals between transceivers. If transceivers are not synchronized, beltpack handover will not happen effectively. This is particularly important if you have overlapping transceiver coverage zones (RF cells) or the beltpacks need to move between coverage zones.

Cable length offset or transceiver sync compensation needs to be set when:

- The difference in total cable length between transceivers is $\geq 1640\text{ft} / 500\text{m}$ (this includes both fiber and copper cable runs).

Example

TCVR #1: total cable length = 328ft / 100m

TCVR #2: total cable length = 2788ft / 850m

The difference in cable length between transceivers = 2460ft / 750m. Therefore, in this case you must set transceiver cable length on both transceivers. This allows any latency to be calculated and offset by the system.

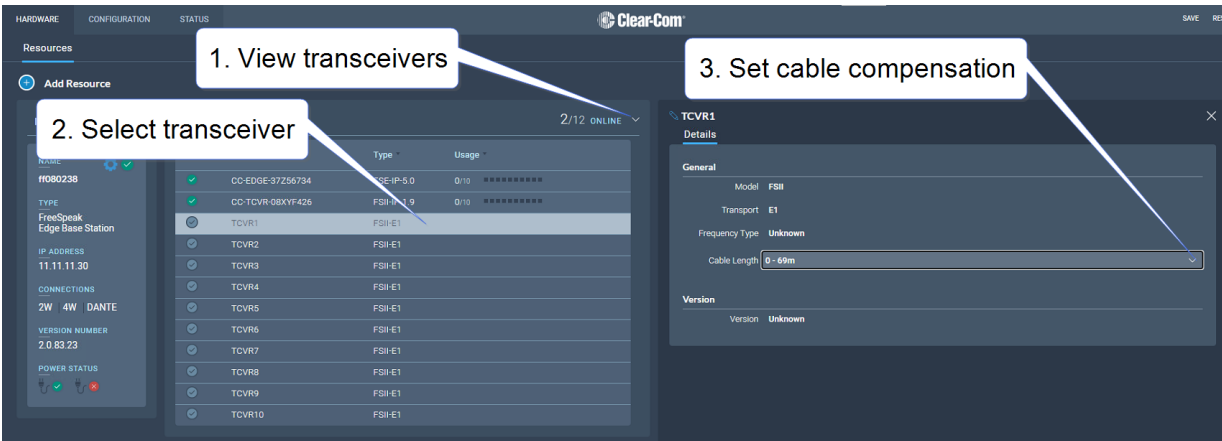

In the configuration tool, navigate to: **Resources > Transceivers > Details > General > Cable Length**

6.3 Adding IP Transceivers

Note: To add E1 transceivers, see [Connecting Transceivers Over E1 on page 107](#).

To add IP transceivers:

1. Navigate to **Hardware > Resources** and select **Add Resource**. The following screen appears.

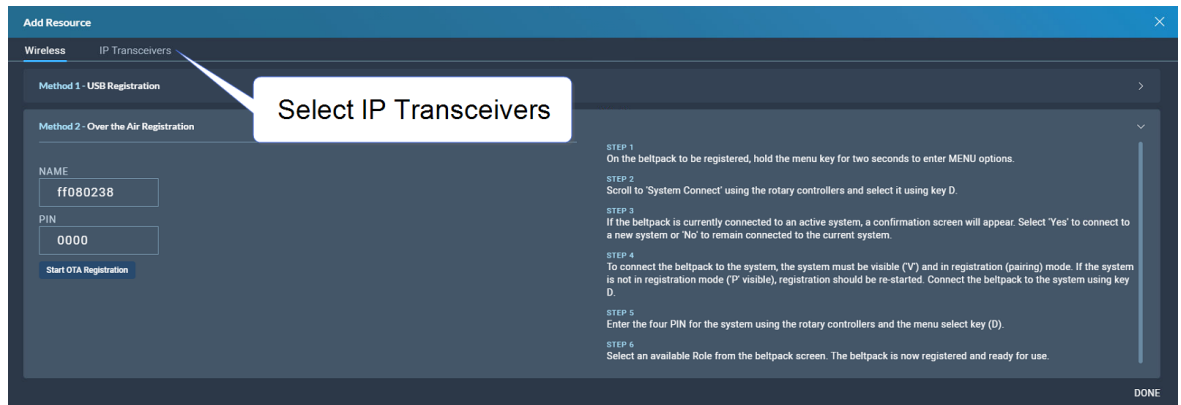

2. Select **IP Transceivers**. The following screen appears:

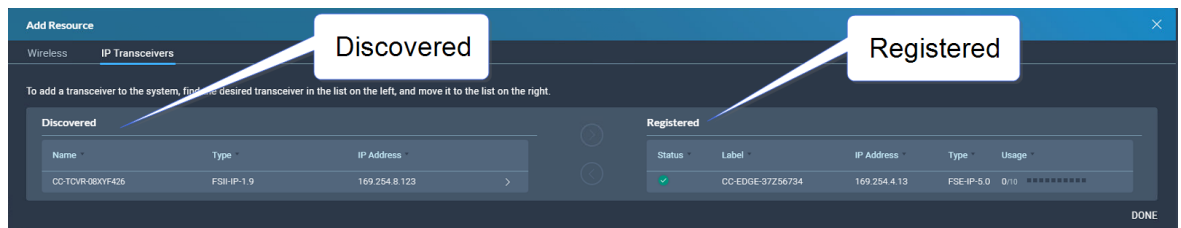

3. Select the transceiver that you want to register from the left-hand area of the screen, and click the right-hand arrow.

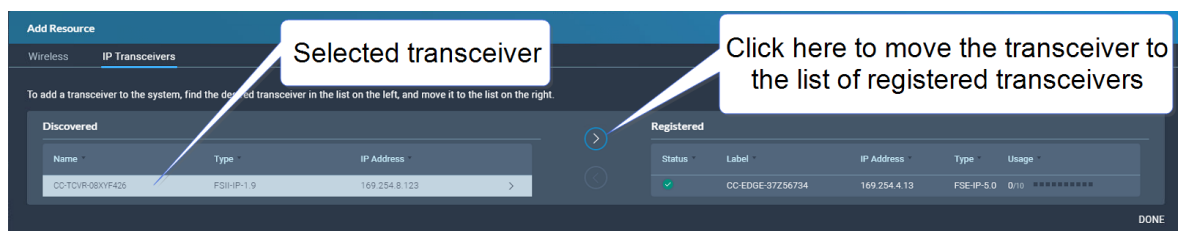

The selected transceiver appears in the right-hand list of registered transceivers.

6.4 Network Setup for IP Transceivers

The Arcadia Central Station has LAN connections assignable to different network traffic such as Management, AES67, Dante and so on.

The LAN ports are fully user configurable but you can work with the following default settings:

- LAN 1: Management (HelixNet/I.V. Direct)
- LAN 2: AES67 for FreeSpeak IP Transceivers
- LAN 3: Not configured (SFP)
- LAN 4: Not configured (SFP)

6.4.1 Connection to IP Transceivers, Example 1

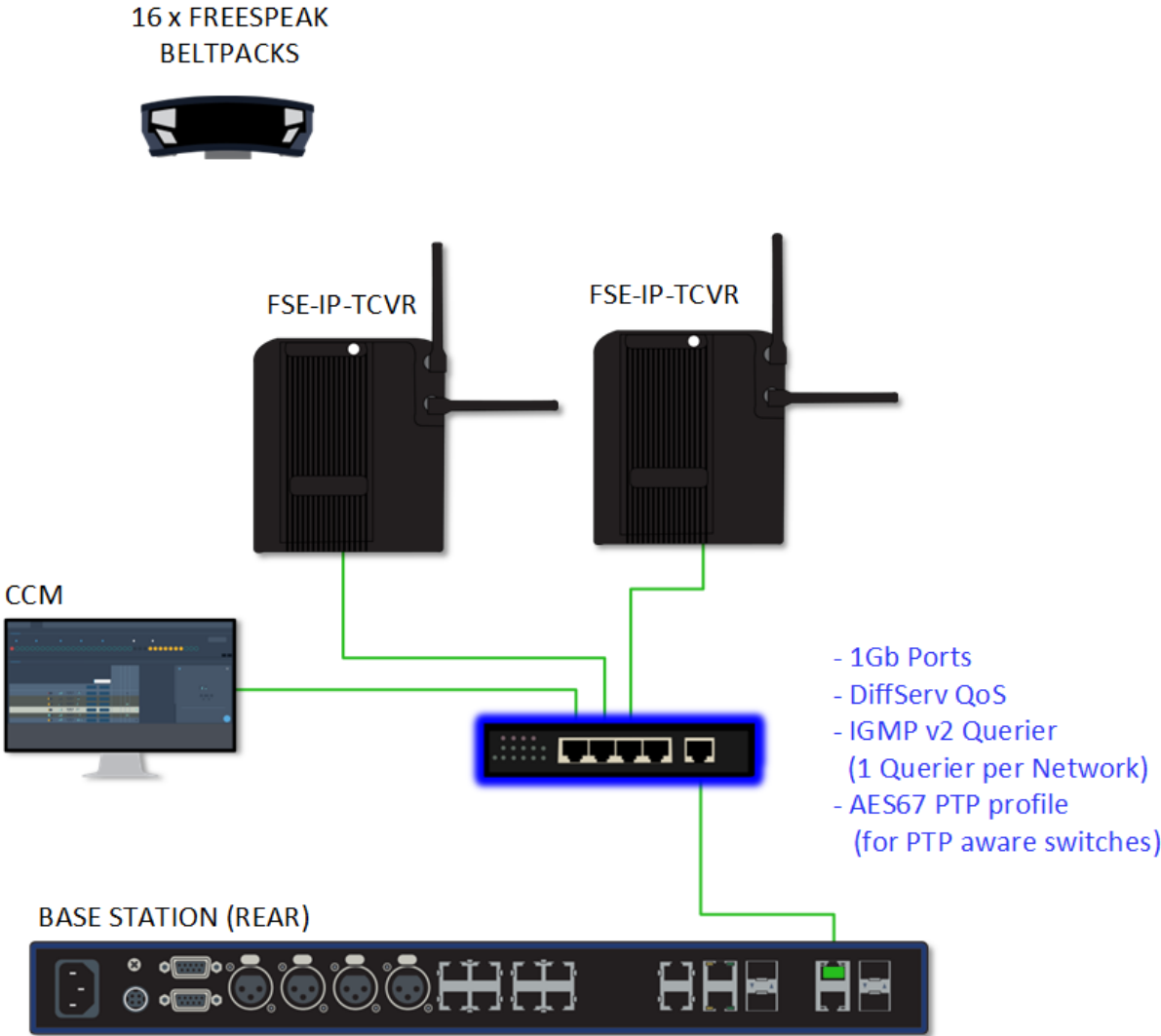

6.4.2 Connection to IP Transceivers and Dante, Example 2

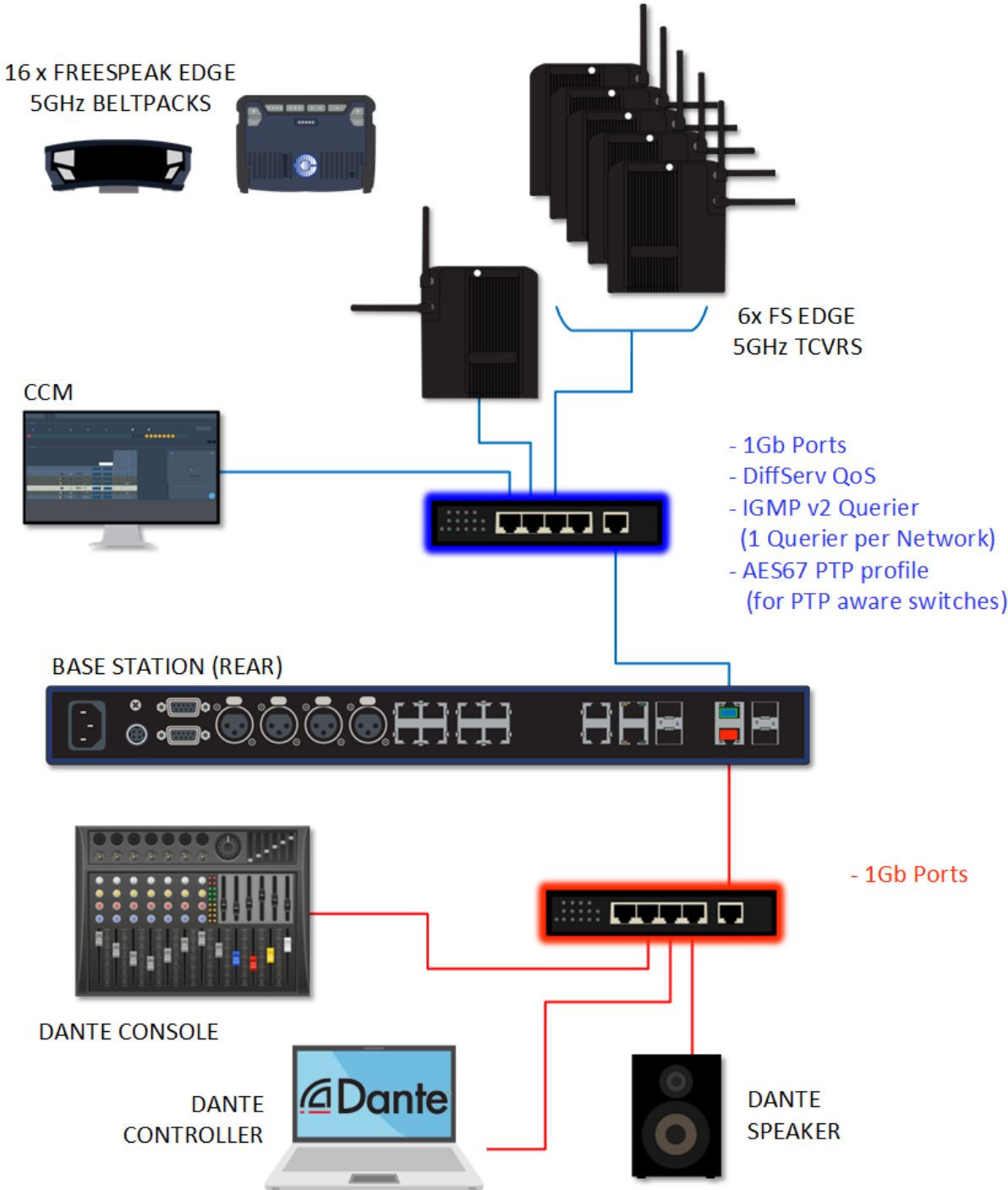

6.4.3 Connection to IP Transceivers and Dante, Example 3

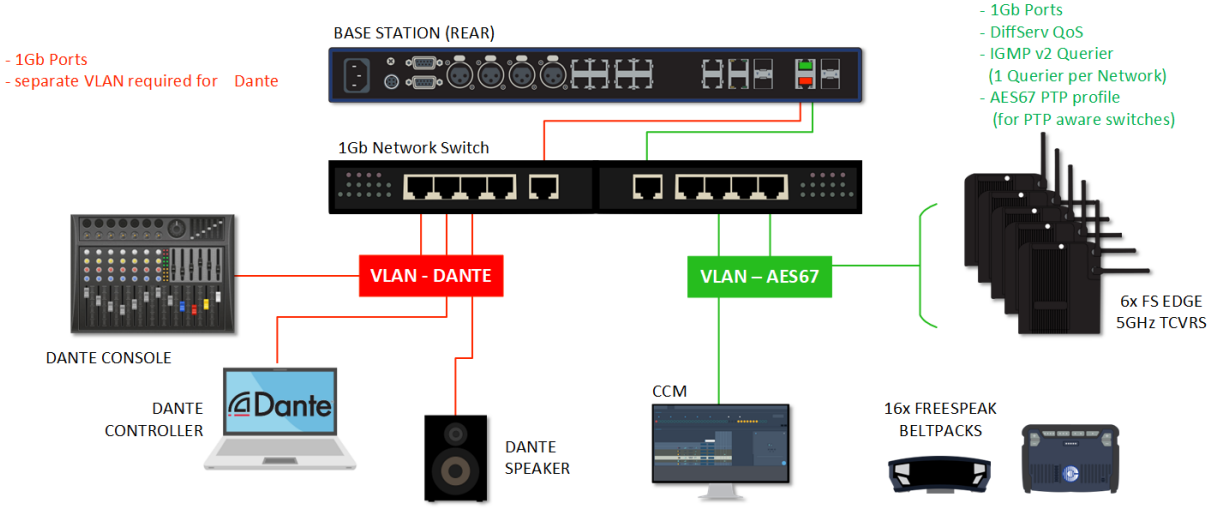

6.4.4 Connection to IP Transceivers, Example 4

If you are connecting to a network set up with heavy traffic, Clear-Com recommends that you split AES67 traffic into its own segment.

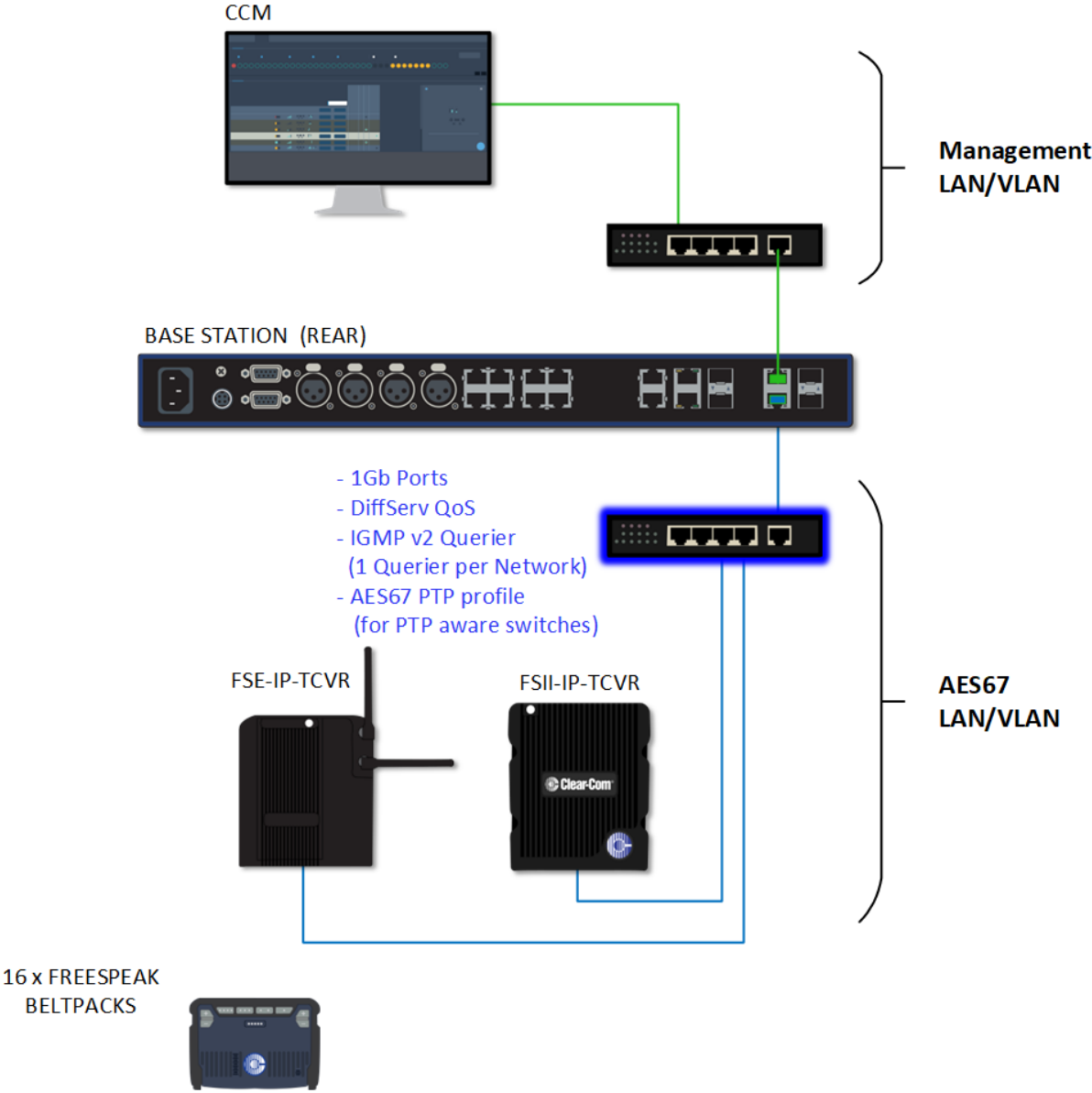

6.4.5 Setup Rules

- The default setup, Management on LAN 1 and AES67 on LAN 2, allows your computer to be connected directly to the Arcadia Central Station for configuration and a dedicated switch to LAN 2 for FreeSpeak IP transceivers. This is in order to accommodate the IP transceivers' need for high clocking accuracy. Heavy traffic on your network will degrade the performance of your IP transceivers.
- For the AoIP network, try to keep the number of layer 2 hops between PTP leader and follower as low as possible (no more than 3). If more are required, consider using a Boundary Clock or a Transparent Clock.
- For more information on achieving a well-regulated PTP network and recommendations for suitable switches, see *Clear-Com AoIP Network Recommendations* available from the [FreeSpeak II Knowledge Center](#).
- Use DHCP (the default setting) for fast and easy setup of the devices. If the device does not encounter a DHCP server on the network it will automatically allocate an address in the link-local range (169.254.xx.xx).
- IP addresses can be configured statically under **Hardware > Resources > Network** in the CCM.
- For information on the 5 GHz transceiver (status and connection indicators) see the *Edge Transceiver Quick Start Guide* available from the [FreeSpeak Edge Knowledge Center](#).
- Connection status indicators on the FreeSpeak II IP transceiver are the same as the Edge transceiver (no channel scan).
- For PoE to the transceivers you will need a PoE capable network switch or PoE injector.

6.5 Registering FreeSpeak Beltpacks

Before you can use a beltpack, you must register it. This enables the Arcadia Central Station to associate the beltpack with roles and assigned keys.

You can register a beltpack in two ways:

- By USB cable. When registering a beltpack in this way, a role that assigns keys to the beltpack is automatically created for the beltpack. The role can be edited as required in the **Configuration > Roles** page of the CCM.
- Over The Air (OTA). When you register a beltpack in this way you must create a role for it manually in **Configuration > Roles** before the beltpack can connect.

6.5.1 Registering a beltpack by USB cable

This method of registering beltpacks is recommended for fast and easy set up.

To register a beltpack using a USB cable, connect a beltpack to Arcadia using a USB A to micro USB B (FSII) / USB C (FSE) cable. The beltpack can be powered on either before or after connection. The Arcadia will show 'Beltpack [ID] is now registered' in the front menu screens.

Note: *When beltpacks are registered in this way, a role with two channels (1 and 2) is automatically generated and applied to the beltpack. Roles can be edited at any time in the **Configuration** page of the CCM.*

6.5.2 Registering a beltpack OTA

To register a beltpack using OTA:

1. Navigate to **Hardware > Resources** and click **Add Resource**. The following screen appears:

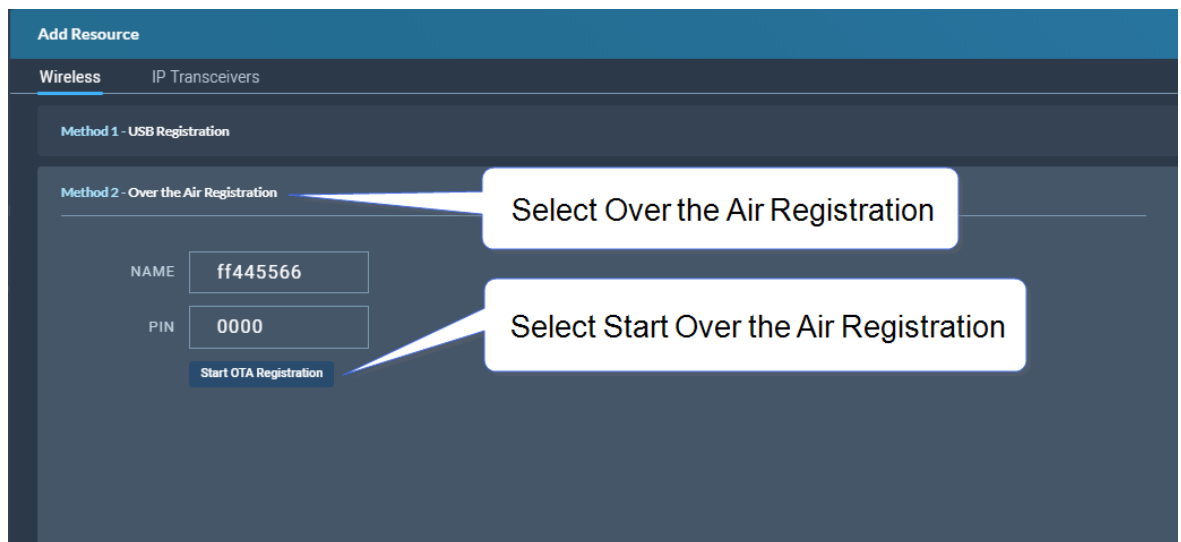

2. Click **Start OTA Registration**.

Note: *A timer is started indicating how long the system is open for registration. You can close OTA registration on the system at any point.*

6.5.3 Unregistering a beltpack

To unregister a beltpack, navigate to **Hardware > Resources > Endpoints** (click the down arrow to see all connected Endpoints (beltpacks)). Select an Endpoint by clicking on it. Select **Unregister**.

EDGE-BP-524403

General

Model FSE

Frequency Type 5.0 GHz

ID 524403

Fixed Role Producer

Version

Version 4.6.79.0

Unregister

Free up any assigned resources and deauthorize endpoint from future connections to this system.

Unregister

6.6 FS Edge Transceivers

Wireless region and channel setup are important when using FS Edge transceivers.

6.6.1 Wireless Region

Your Edge transceiver has a wireless region pre-configured, in order to comply with regional regulations. The wireless region setting in the CCM MUST match that of your transceiver, or the system will not work. You will see an error message in the **Status** page if the regions do not match.

To set the wireless region in the CCM, navigate to: **Hardware > Host > Wireless > Wireless Region**.

Please contact your Clear-Com representative if you have difficulties with this.

The screenshot displays the Clear-Com web interface for configuring a host device. The top navigation bar includes 'HARDWARE', 'CONFIGURATION', and 'STATUS' (with a warning icon and '1'). The 'Host' page is active, showing a sidebar with device details for 'ff080925' (Arcadia Central Station) and a main configuration area. The 'Wireless' tab is selected, showing the following settings:

- General:** Administration PIN (1111), System ID (925), BP Role List Sorting (Role Number).
- Freespeak Edge:** Edge Wireless Region (US), Excluded Channel(s) (Unassigned), and a 'Scan All EDGE Transceivers' button.
- Freespeak II:** Splitter/Transceiver 1 (RJ45), Splitter/Transceiver 2 (RJ45), Audio RF Filter (Enabled), AA Battery Type (Alkaline), and Over The Air (OTA) PIN (0000).

A callout bubble points to the 'Edge Wireless Region' dropdown menu, containing the text 'Edge wireless region'.

6.6.2 Channel Scanning

The FreeSpeak Edge transceiver system will automatically select channel 1, 2 and a backup channel (if using DFS channels) on each transceiver when you set it up. For best performance, it is necessary to ensure that selected channels are clear of interference from other devices. You can use the channel scanning feature and auto select the best channels for each transceiver. Channel scanning will scan all the 5 GHz channels in your local RF space.

To conduct a channel scan, navigate to: **Hardware > Resources > Transceivers [select transceiver] > Wireless Channels** and select **Refresh Scan**.

After channel scanning, to auto select the optimum channels for each transceiver use **Auto Select**.

The screenshot displays the 'Wireless Channels' configuration page for device CC-EDGE-26YYF731. It includes a 'Refresh Scan' button and an 'Auto Select' button. A bar chart shows channel scores from 36 to 165, with a legend for Low Availability (red), Medium Availability (yellow), High Availability (green), and Configured Elsewhere (hatched). Below the chart is a table with columns for Channel, Score, RSSI, Use, Ap, and SSID.

| Channel | Score | RSSI | Use | Ap | SSID |
|---------|-------|------|-----|----|--|
| 36 | 22 | 22% | 0% | 3 | Cambridge_Guest, Cambridge_Users, Unknown System |
| 40 | 28 | 21% | 0% | 2 | Cambridge_Guest, Cambridge_Users |
| 44 | 22 | 21% | 13% | 3 | Edge System, Cambridge_Guest, Cambridge_Users |
| 48 | 28 | 21% | 0% | 2 | Cambridge_Guest, Cambridge_Users |
| 52 | 16 | 28% | 13% | 3 | Edge System, Cambridge_Guest, Cambridge_Users |
| 56 | 36 | 16% | 4% | 2 | Cambridge_Guest, Cambridge_Users |
| 60 | 15 | 29% | 14% | 3 | Edge System, Cambridge_Guest, Cambridge_Users |

Refresh scan

Auto select best channels

Click on a channel to go to details for that channel in list view

In this case you can see that the selected channels have low availability. It will be helpful to use auto select to find the optimum channels for this transceiver

You can see all available channels here. Scroll down to view

6.6.3 Channel Score

Channel **Score** is calculated using a weighted combination of:

- **RSSI** (Received Signal Strength Indicator)
- Channel activity (**Use**)
- Access points (**Ap**)

To scan all the transceivers in your network simultaneously, go to **Hardware > Host > Wireless > FS Edge > Scan All Edge Transceivers**.

For more detail on using FreeSpeak Edge transceivers, see the FreeSpeak Edge User Guide available online from the Clear-Com FreeSpeak Edge [Knowledge Center](#).

7 Using HelixNet Wired Partyline Intercom

This chapter describes how to connect to HelixNet Wired Partyline Intercom. It contains the following sections:

- 7.1 Introduction 124
- 7.2 HelixNet Connections - General Outline 125
- 7.3 Connecting HelixNet User Stations to the network 126
- 7.4 Pairing HelixNet User Stations to Arcadia 126
- 7.5 Connecting User Stations via Digital Powerline Device 129
- 7.6 Digital Powerline Device Statistics and Messages 130

7.1 Introduction

Arcadia supports HelixNet wired partyline intercom, including the remote station, the speaker station and the beltacks. HelixNet user stations connect to Arcadia via an ethernet network and HelixNet keysets can be assigned to any HelixNet enabled channel in the Arcadia system. Each HelixNet enabled channel requires an Arcadia licensed port.

HelixNet beltacks, remote stations and speaker stations are connected to the Arcadia on the LAN port that is configured for the HelixNet network (default LAN 1) via an Ethernet network.

HelixNet user stations can also be connected to the Arcadia via the HelixNet Powerline Device. HXII-DPL acts as a bridge between Ethernet and Powerline, enabling connection and powering of devices on the Powerline using standard XLR microphone cable and passive splits.

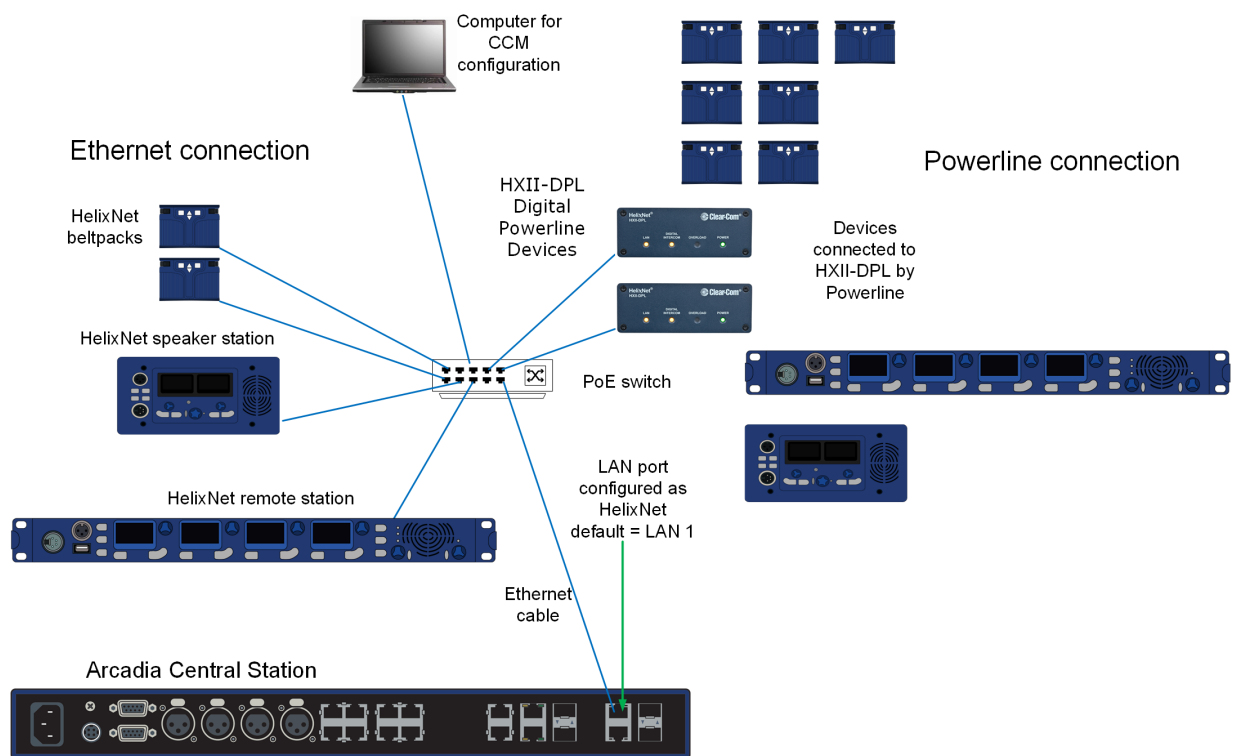

Note: Arcadia's HelixNet network is combined with the Management network and cannot be separated at the time of writing.

Note: When using an IEEE-802.3af compliant PoE switch, be sure to note the switch's power budget. Each HXII-BP requires 4 Watts of power. The HelixNet remote and speaker station each require 15.4 Watts of power from the switch. Do not exceed the power budget of the switch when attaching devices. For devices connected via Powerline see the HelixNet Powerline Calculator available from the HelixNet Knowledge Center.

Note: You can enable up to 24 channels for HelixNet. How many channels you use is limited by how many port licenses you have. One HelixNet enabled channel consumes one port license.

Note: User station keysets can be assigned to any HelixNet enabled channel.

Note: *HelixNet should be listed in the CCM under **Hardware>Host**. If it is not listed and your device is manufactured before June 1st 2022 it may require a HelixNet activation license. Please contact Clear-Com Sales for further information.*

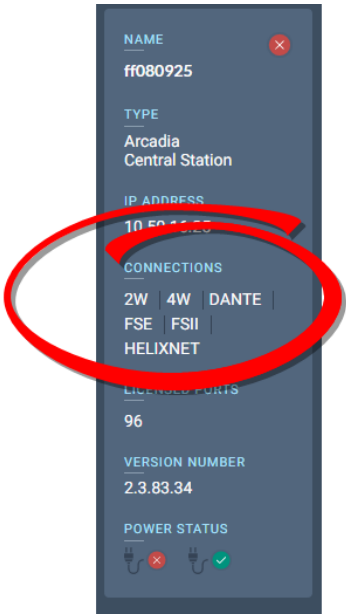

See the *HelixNet for Arcadia User Guide*, available from the [HelixNet Knowledge Center](#) or more information on the HelixNet system and components.

7.2 HelixNet Connections - General Outline

Before connecting HelixNet beltpacks you must have:

- At least 1 channel enabled for HelixNet (by default, channels 1 - 4 are enabled). See [Enabling Channels for HelixNet on page 75](#)
- Sufficient number of licensed ports for the HelixNet enabled channels (max 24)
- **Port Type** on at least 1 licensed port set to type **Any** (default) or **HelixNet**. If this is not done, HelixNet keysets cannot be assigned

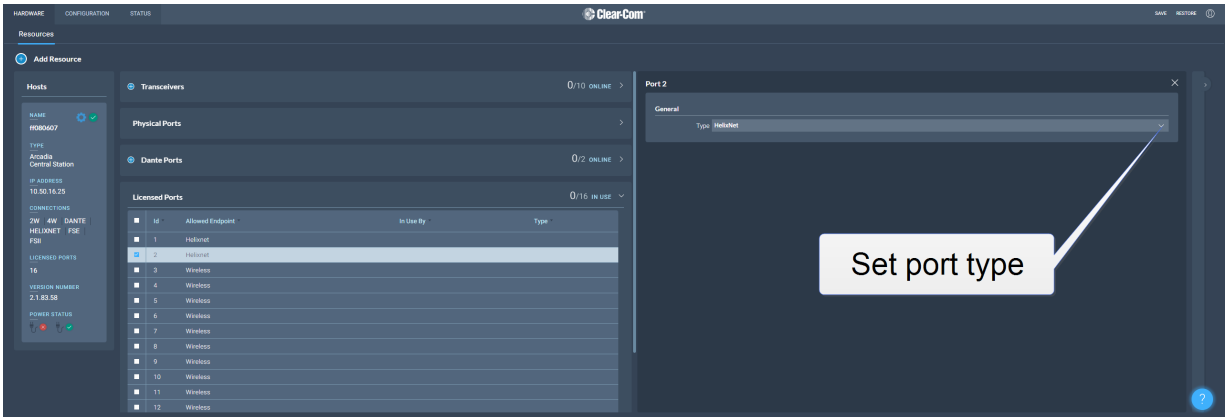

For a quick test setup, you can work with the default settings which allow licensed ports to be used for any function and have 4 channels HelixNet enabled. For a full installation, you can enable channels and create roles for HelixNet beltpacks, remote stations and speaker stations.

7.3 Connecting HelixNet User Stations to the network

HelixNet wired devices are connected to Arcadia's HelixNet network using the RJ45 ethernet connector on the back of each device.

HelixNet beltpack base connectors



Connect RJ45 Ethernet cable here

HelixNet remote station rear connectors



Connect power supply unit (PSU) here

Connect RJ45 Ethernet cable here

HelixNet speaker station enclosure (rear connectors) housing A speaker station



Connect RJ45 Ethernet cable here

Connect power supply unit (PSU) here

7.4 Pairing HelixNet User Stations to Arcadia

Once connected to Arcadia's HelixNet network and appropriately powered, HelixNet beltpacks, remote stations and speaker stations can be paired to the Arcadia system:

- from the CCM
- from the HelixNet user station, using the front panel menu

Note:

*Troubleshooting: you may need to make sure that the connecting device is in the same IP range as the host system. To view and edit the device IP address, navigate to **Networking>Preferences>IP address** in the device menu system.*

Note: Pairing from the CCM is available for endpoints that were last used on a HelixNet HMS-4X based system version 4.4 and higher. Endpoints migrating from HMS-4X version 4.2 or earlier to an Arcadia system must initially be paired from the front panel menu of the HelixNet user station.

7.4.1 Pairing/unpairing HelixNet User Stations in the CCM

When the user stations are connected to the Arcadia HelixNet network and appropriately powered, they will appear as **Discovered** in the CCM.

1. In the CCM, navigate to **Hardware>Resources>Add Resource**  **>Wired** .
2. Select the device under **Discovered** and click the arrow to move it to **Paired**.
3. The device will work through its connection sequence.
4. The device is ready for use.

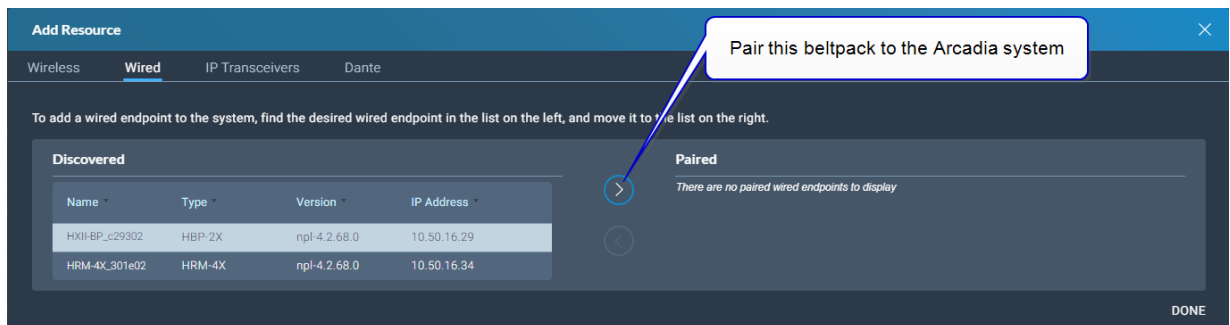

Repeat this step for each device.

Note: The device will automatically update on connection if a difference in firmware versions is detected between the Arcadia and the HelixNet Endpoint.

Note: HelixNet Endpoints manufactured in January 2023 (serial number ends with C00 or higher letter/number) or later can only be used with Arcadia version 2.8 or HMS-4X version 4.4. These endpoints cannot be used with older versions due to difference in hardware components.

Once paired to a system, the device will automatically connect to that system whenever it is connected to the network. The devices can be unpaired from the system to prevent this from happening. To unpair a device from the system, navigate to **Hardware>Resources>Endpoints [select device]>Unpair**.

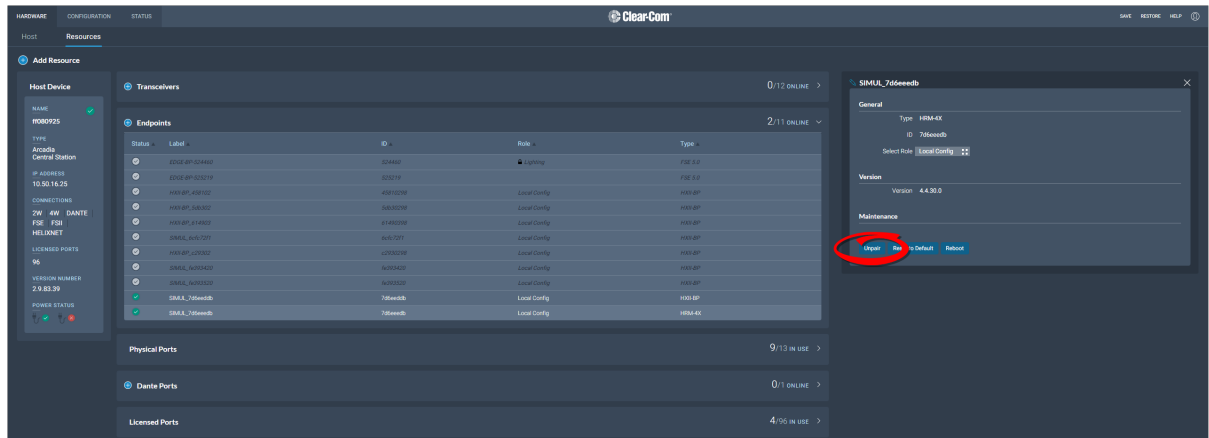

7.4.2 Pairing HelixNet user stations from the front panel menu

Beltpacks

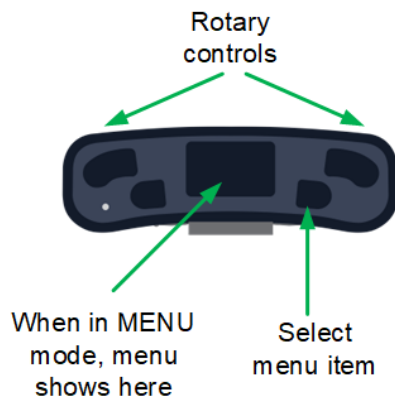

1. Press the **Menu** button on the front of the beltpack (short press) to enter menu mode.
2. Press the left call button on the beltpack (**back**). You will see the beltpack menu system.
3. Using the rotary controls and the right call button (**select/enter**), navigate to **Networking>Pair to Station**.
4. Select either;
 - **Pair by Name** and select the name of Arcadia
 - **Pair by IP** and enter the IP address of Arcadia's HelixNet LAN connector

Note: You need to **Save** the IP address (right call button).

Remote stations and speaker stations

1. Press the **Menu** button to enter menu mode.
2. Using the rotary controls, navigate to **Networking>Pair to Station**.

3. Select either;
 - **Pair by Name** and select the name of Arcadia
 - **Pair by IP** and enter the IP address of Arcadia's HelixNet Network using the rotary controllers

Note: *All devices will automatically update on connection if a difference in firmware versions is detected.*

7.4.3 Using HelixNet user stations on Arcadia

Once the HelixNet user station is connected to the Arcadia and the firmware updated if necessary, the HelixNet user station can be configured.

Arcadia's default configuration assigns the first channels of the system to the HelixNet user stations on connection.

HelixNet user stations can be operated in **Local Config**. In this case, the user station is fully configured from its front panel menu. Any of the connected Arcadia's HelixNet enabled channels can be assigned to the keysets of the user station.

Where central management is required, **Roles** can be created in the Arcadia's CCM and then assigned to the HelixNet user station, either from the CCM's **Hardware>[Endpoint]>Properties** or in the front panel menu of the user station. A role is a configuration of the keysets and settings of the user station. Multiple HelixNet devices can share a role and any role changes will be updated in real time.

- Create roles for your devices. See *Managing Roles* in the *Arcadia User Guide*.

For HelixNet manuals and other resources see:

[The HelixNet Knowledge Center](#) on the Clear-Com website.

7.5 Connecting User Stations via Digital Powerline Device

HXII-DPL Powerline device connects to your Arcadia via network and must be powered using the supplied power supply (PSU-EXT-005). Multiple HXII-DPL Powerline devices (24 max) can be added to a system either at a central location, or, for best performance, locally where connections to HelixNet user stations are needed.

Note: *HelixNet user stations must run HelixNet firmware v.4.5 (included with Arcadia 2.11+) before use with the HXII-DPL Powerline device.*

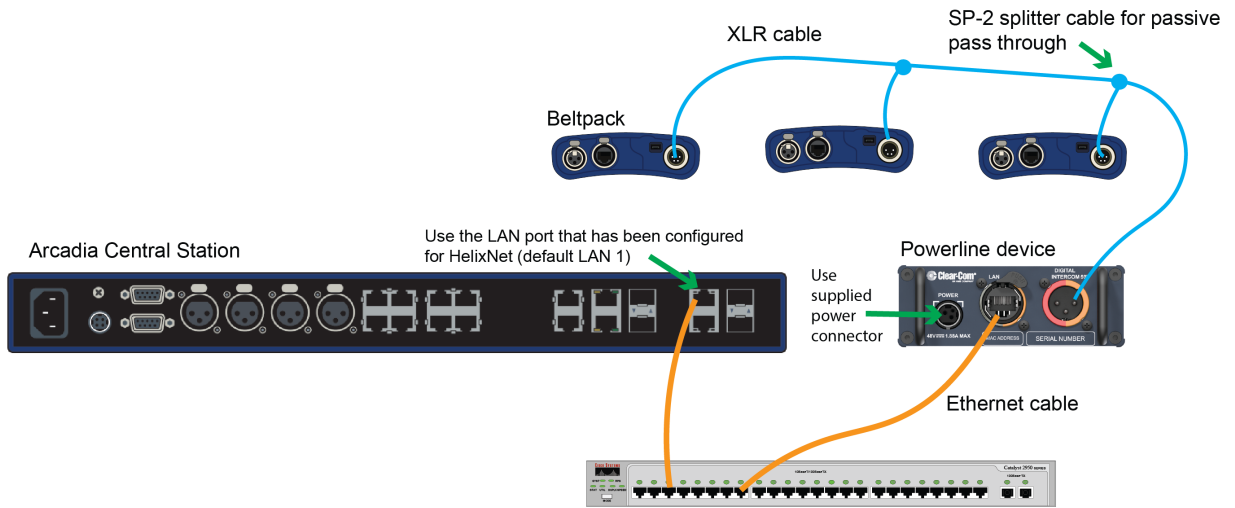

Connect the HXII-DPL Powerline device to HelixNet user stations using 3-pin XLR cabling, via passive splits or daisy chaining as appropriate.

Once physically connected and powered, the HelixNet user stations can be paired to the system.

HXII-DPL Powerline device does not need to be paired to the system. It is not visible in the CCM (**Status > Overview > Wired**) on first connection until a HelixNet endpoint is paired and connected via the device.

7.6 Digital Powerline Device Statistics and Messages

You may see the following statistics and messages in the Arcadia Central Station CCM:

| Powerline statistics | |
|----------------------|---|
| Collision rate | 25-35% - high ≥ 35% - very high |
| Error rate | 0-0.1% error - low data quality ≥ 0-0.1 % error - very low data quality |
| Bandwidth | 40 - 130 Mbps - working range 15 - 40 Mbps - low data rate ≤ 15 Mbps - very low data rate |
| Voltage | < 18 V DC - very low power < 24 V DC - low power > 24 < 31 V DC - working range > 31 V DC - high power |

| Condition | Steps to take |
|---|---|
| The Powerline data collisions are high or very high | <ol style="list-style-type: none"> 1. Check if Powerline is overloaded 2. Check cable shielding 3. Check HelixNet user stations |
| The Powerline data quality is low or very low Note: can be caused by external interference or too many devices trying to use the same carriers | <ol style="list-style-type: none"> 1. Check if Powerline is overloaded 2. Check for cross-connected Powerlines 3. Check cable shielding 4. Check HelixNet user stations |
| The Powerline voltage is low/very low | <ol style="list-style-type: none"> 1. Check if the Powerline is overloaded |
| The Powerline voltage is high | <ol style="list-style-type: none"> 1. Check the HelixNet user station and the cable that connects it |
| <i>The Powerline voltage at [name] endpoint is unbalanced.</i> | <ol style="list-style-type: none"> 1. Check cabling for continuity and resistance between pin 2 and 3 2. Check the HelixNet user station |
| <i>HXII-DPL Powerline device is not reachable.</i> | <ol style="list-style-type: none"> 1. Power cycle the Powerline device and the connected user stations 2. Contact Clear-Com if the problem persists |
| <i>HXII-DPL Powerline device has a connection >7.</i> | <ol style="list-style-type: none"> 1. Check the number of connected HelixNet user stations 2. If the problem persists when the number of connected units is ≤ 7, check the integrity of the Powerline cable shields |

Note: *To ensure good audio quality, consider adding more HXII-DPL Powerline devices to your system.*

8 Using I.V. Direct

This chapter describes how to use and configure I.V. Direct connections. It contains the following sections:

- 8.1 What is I.V. Direct? 133
- 8.2 I.V. Direct Configuration Overview 134
- 8.3 Connecting I.V. Direct on your Network 138
- 8.4 Configure I.V. Direct in the Arcadia CCM 139
- 8.5 Using GPIO with I.V. Direct 143

8.1 What is I.V. Direct?

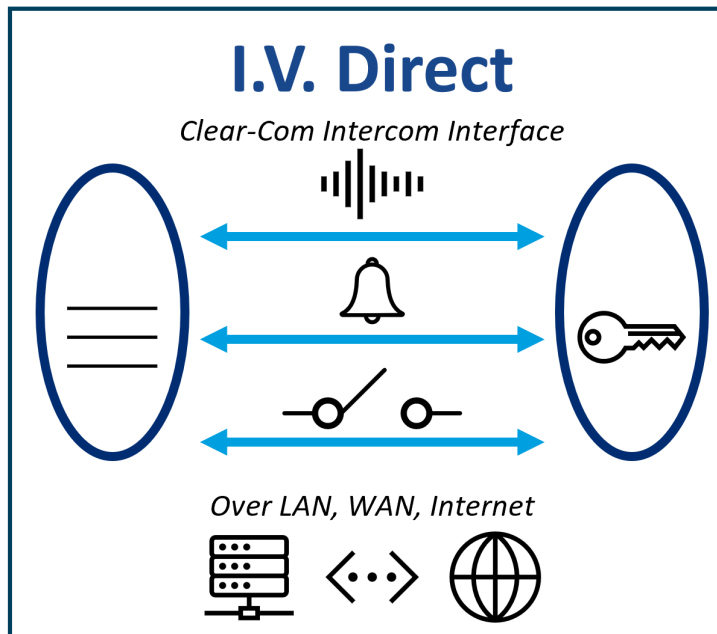

I.V. Direct/IVC Direct ports enable a variety of IP connections to Clear-Com products, and maybe be used, for example, for:

- Intercom expansion via LQ
- Intercom system bridging

Clear-Com Instant Voice I.V. Direct uses proprietary technology providing LAN, WAN and Internet with optional external IP connectivity.

I.V. Direct ports connect to:

- LQ units - max. 8 ports per LQ
- E-IPA-HX card (and IVC-32 card) - max. 64* ports per E-IPA card
- Arcadia - max. 16* ports per Arcadia

* Subject to licensed port capacity

Features include:

- Audio
- Call and Virtual GPIO (LQ only)
- Routable and robust on a network
- Security with user ID and password on each connection

8.2 I.V. Direct Configuration Overview

Below are some concepts to understand before undertaking I.V. Direct configuration.

8.2.1 Signalling or No Signalling?

I.V. Direct connections to LQ units carry call-signalling and data (GPIO). When creating a port to connect with an LQ, you will select Signalling **Enabled**.

I.V. Direct connections to another Arcadia or to an Eclipse matrix do not carry call-signalling and data. When creating a port of this type, you will select Signalling **Disabled**.

8.2.2 VOIP Caller/Receiver

I.V. Direct is a port containing audio and optionally call and virtual GPIO signals. I.V. Direct includes a security layer where credentials must be setup to establish the connection between a caller that initiates the connection and a receiver that has the credentials of the connection.

I.V. Direct Example A - LQ to Arcadia

When configuring I.V. Direct connections to LQ units, the LQ unit always calls the Arcadia (or Eclipse matrix). The LQ is never the VOIP receiver and no specific VOIP caller/receiver configuration is required.

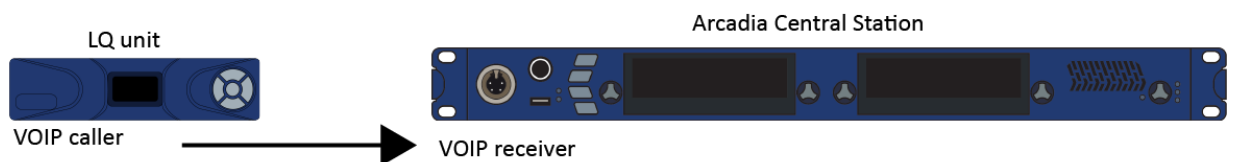

For information on creating and configuring I.V. Direct ports in LQ , see the LQ User Guide available from the [Clear-Com LQ Knowledge Center](#).

I.V. Direct Example B - Arcadia to Arcadia

When configuring I.V. Direct connections from an Arcadia to another Arcadia, one device must be the VOIP caller while the other one is the receiver.

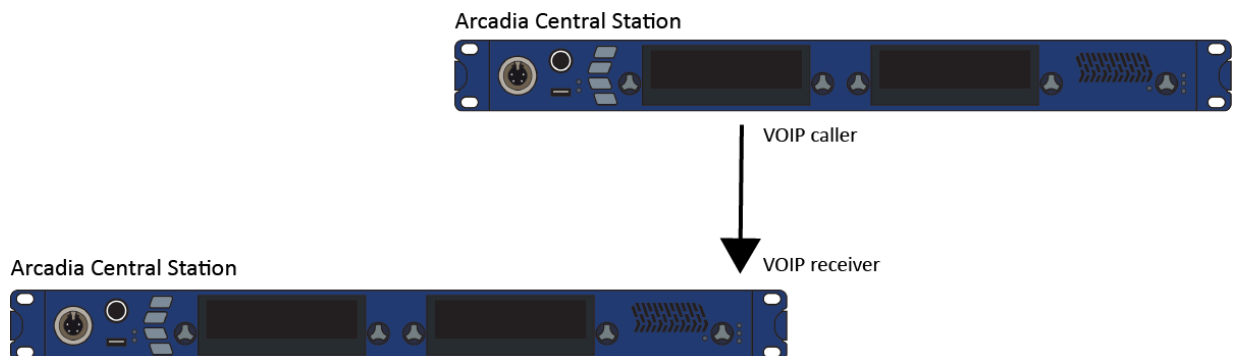

I.V. Direct Example C - Arcadia to Eclipse Matrix

When configuring I.V. Direct connections from an Arcadia to an Eclipse matrix, one device must be the VOIP caller while the other device is the receiver.

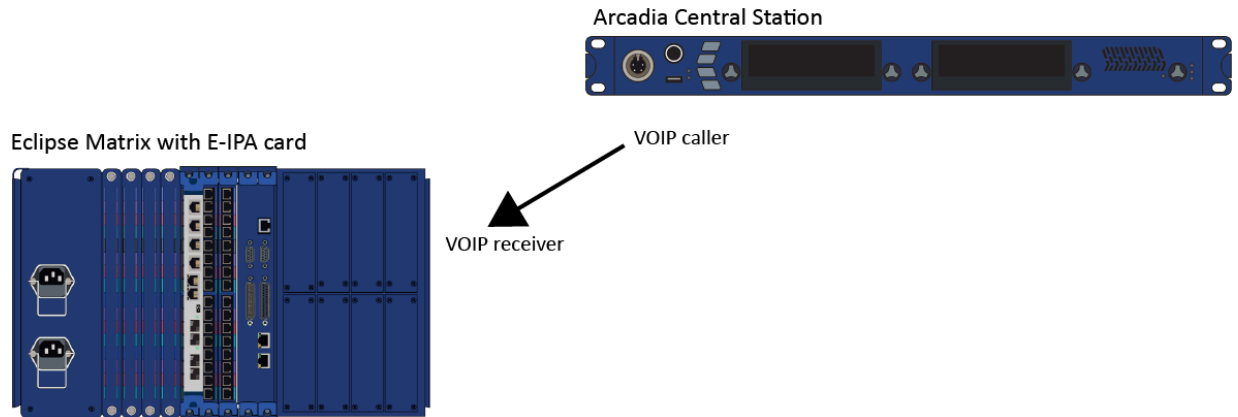

When configuring an I.V. Direct connection to Arcadia or Eclipse, you will determine which device is the caller by enabling the VOIP checkbox in the port credentials tab. (**Hardware > Resources > I.V. Direct** [select port] > **Credentials**).

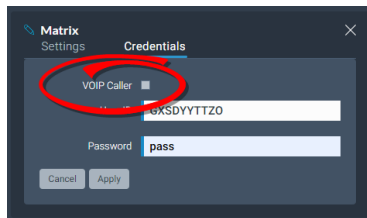

For information on creating and configuring I.V. Direct ports in Eclipse HX Matrix, see the EHX User Guide available from the [Clear-Com Knowledge Center](#).

8.2.3 Credentials

Each I.V. Direct connection must have a **User ID** (unique) and **Password** (recommended). These are the credentials that are used for identifying a connection target on the network, and for security. The User ID and Password are created on the VOIP receiving device, also known as the remote device. The VOIP calling device must enter the IP address of the remote device as well as the User ID and Password. The credentials must be copied exactly between the VOIP receiving (remote) device and the VOIP calling device to establish a successful connection.

Note: *Devices that are calling in to an Arcadia must use TCP/IP port 6002. This is hard-coded and cannot be changed.*

8.2.4 I.V. Direct Ports Enabled/Disabled

I.V. Direct ports can be created and configured in the Arcadia CCM up to a maximum of 16 I.V. Direct ports per Arcadia. However, the active use of these ports is reliant on licensed port capacity. When the ports are enabled in port settings (default is enabled), they will connect according to licensed port capacity on a first come, first served basis. If there is no available licensed port (of type **Any** or **I.V. Direct**), the connection will be refused until such time as a licensed port becomes available. If a license on an I.V. Direct port that is in use is reassigned or changed, the connection will be ended and you will lose audio connection on that port.

8.2.5 Configuration Overview

Arcadia CCM

1. Create an I.V. Direct port
 - a. Signalling - For LQ connection
 - b. No Signaling - For Eclipse & Arcadia connection
2. Configure settings
3. Configure credentials
 - a. User ID
 - b. Password
 - c. VOIP caller?
 - i. If VOIP caller, input the IP address of the target device
4. Apply

Target Device (LQ, Arcadia or Eclipse matrix)

1. Create I.V. Direct port
2. Configure settings
3. Configure credentials
 - a. User ID
 - b. Password
 - c. VOIP caller? IP address of the Arcadia or Eclipse IP card is required if this is the calling device
4. Connect/Apply/Apply map to matrix

Configuration for connecting devices:

LQ : in the CCM, navigate to **Accounts > IVC Direct** to add ports.

Eclipse matrix: in the EHX software, navigate to **Hardware > Cards and Ports** [select E-IPA or IVC-32 card] > Add port type **IVC Direct**.

8.3 Connecting I.V. Direct on your Network

Arcadia v. 3.0 or later

LQ v. 4.0 or later

Eclipse HX v. 7.5 or later with E-IPA or IVC-32 card

All devices must be using the correct firmware version before I.V. Direct connections are set up. Arcadia Central Station and the target systems for I.V. Direct connection(s) (LQ, Eclipse matrix , Arcadia) are connected to your network via device LAN connectors using Cat5/6e Ethernet cable. The devices must be able to reach each other across the network.

I.V. direct traffic uses the Arcadia Management LAN (default LAN 1).

8.3.1 Example I.V. Direct Network Connections

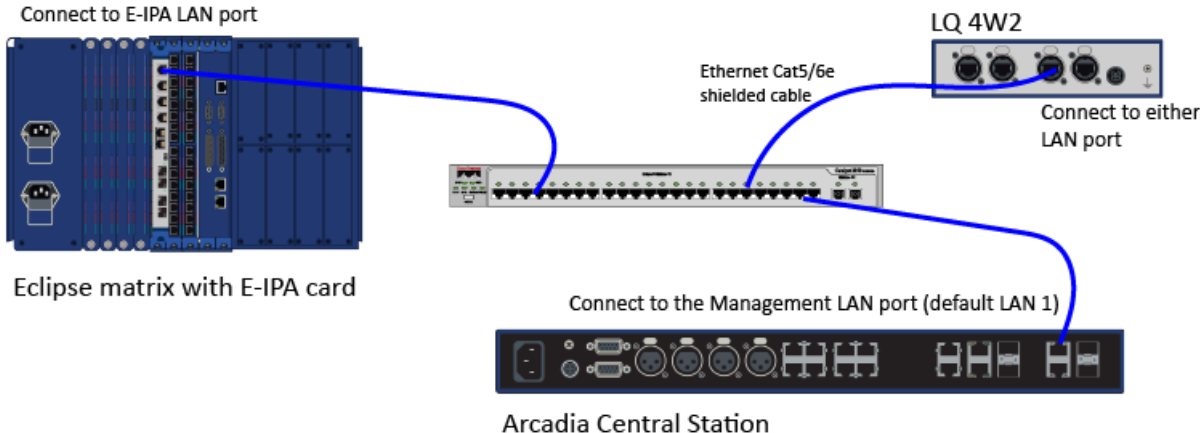

8.4 Configure I.V. Direct in the Arcadia CCM

Create ports and user credentials (user ID, password, and IP address as needed).

1. Open the the Arcadia CCM (find the device IP address in the front panel menu system).
Navigate to **Hardware > Resources**.



2. Click the **Add Resource** button.
3. Make sure the **I.V. Direct** tab is selected.
4. Give the port a label.
5. Select signaling **Enabled** (if connecting to an LQ) or **Disabled** (if connecting to and Eclipse IP card or Arcadia).
6. Click **Create**.

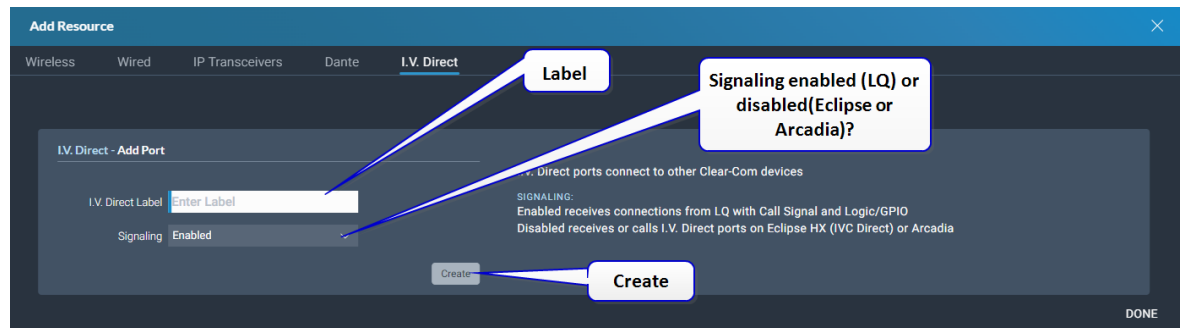

7. The **Add Resource** window stays open so you can create more than one port. Close the window or click **Done** when you have finished creating new ports.
8. Select the newly created I.V. Direct port for **Settings** and **Credentials**.
9. Configure settings:

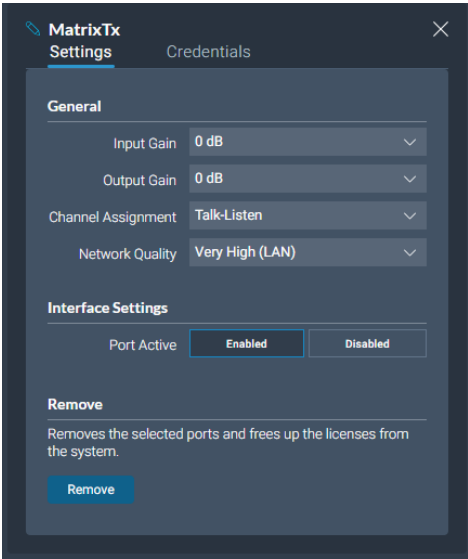

An I.V. Direct port needs a license. If you disable the **Port Active** checkbox (default is Enabled), the port will remain in your configuration but will not consume a license. You will not be able to transmit audio on this port if it is disabled, or if there is no license available.

- 10. Configure credentials. Configuration of credentials varies according to the device you are connecting to:

For more information see: [I.V. Direct Configuration Overview on page 134](#)

Note: Calls to an Arcadia must use TCP/IP port 6002. This is pre-configured and cannot be changed.

11. Click **Apply**.

Connected IV ports

| Status | Label | User ID | Password | Signaling | Channel Assignment |
|--------|------------|------------|------------|-----------|--------------------|
| ✓ | MatrixTx | 627D7335C9 | 9D9514575B | | Talk-Listen |
| ✓ | MatrixRx | ICRSMQLMQY | pass | | Talk-Listen |
| ✓ | LQ-R_2 | PTDICVXBDD | pass | ✓ | Talk-Listen |
| ✓ | LQ-R | UERFGHJTEV | pass | ✓ | Talk-Listen |
| ⊘ | MatrixTx-2 | RXOEXRAEOD | | | Talk-Listen |

I.V. Direct ports will connect when both connecting devices have been networked and configured. For status and connection information, and to configure GPIOs, go to **Status > Overview > I.V. Direct** [select port].

Example connection statistics for and I.V. Direct with signalling (LQ)

Example network statistics for and I.V. Direct with signalling (LQ)

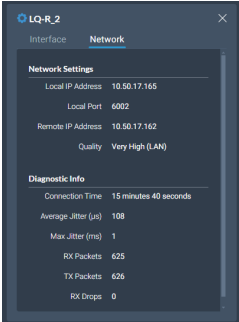
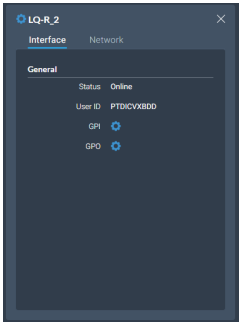

Error messages - I.V. Direct

Click or hover on the red cross to see error messages

| Status | Label | User ID | Password | Signaling | Channel Assignment |
|--------|------------|----------|----------|-----------|--------------------|
| ⊘ | ARlistener | listener | here | | Talk-Listen |
| ⊘ | | | | | Talk-Listen |
| ⊘ | TestPort0 | Test0 | | ✓ | Talk-Listen |

In the event of a connection failure you will see the following error messages:

| Message | Reasons for closing the connection |
|---|---|
| <p><i>Local endpoint application cleared call</i></p> <p>The local device has closed a connection</p> | <p>The License was removed on the local side (Arcadia) for an active I.V. Direct connection</p> <p>The username and password were changed on the local side (Arcadia) for an active I.V. Direct connection</p> <p>There are no free licenses for I.V. Direct ports on the local side</p> |
| <p><i>Remote endpoint application cleared call</i></p> <p>The remote device has closed the connection</p> | <p>The username and password were changed on the remote side (LQ/Arcadia/EHX) for an active connection</p> <p>The License was removed on the remote side (LQ/Arcadia/EHX) for an active connection</p> <p>The I.V. Direct port was disabled on the remote side (LQ/Arcadia/EHX) for an active connection</p> <p>There are no free licenses for I.V. Direct ports on the remote side</p> |
| <p><i>Call failed a security check and was ended</i></p> | <p>The username or password is wrong</p> |

Configuration for connecting devices:

LQ : in the CCM, navigate to **Accounts > IVC Direct** to add ports.

Eclipse matrix: in the EHX software, navigate to **Hardware > Cards and Ports** [select E-IPA card] > Add port type **IVC Direct**.

For information on creating and configuring I.V. Direct ports in LQ or Eclipse HX Matrix, see the User Guide for those products, available from the [Clear-Com Knowledge Centers](#).

8.5 Using GPIO with I.V. Direct

Below is an example of using a radio connection with an I.V. Direct with GPIO. An I.V. Direct has been configured between the Arcadia (AR-Radio) and the LQ (VR-Radio). GPIOs exchanged between AR-Radio and VR-Radio are virtual via the I.V. Direct. The GPO to the radio is a physical connection from LQ with GPIO.

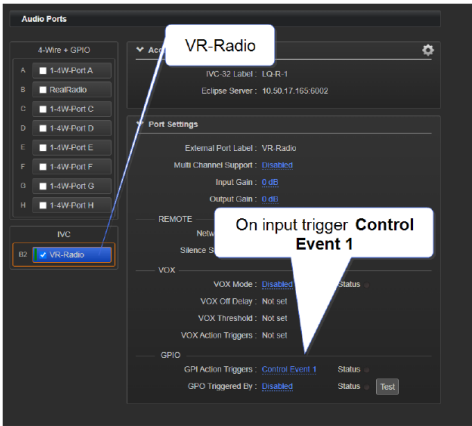
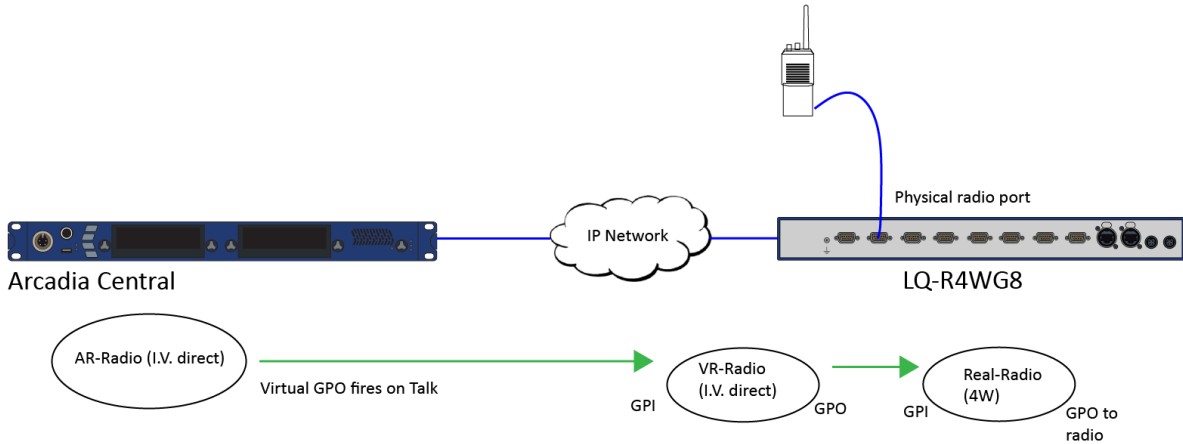

Arcadia and I.V. direct port AR-Radio are put in a channel together
 Key assignment to the channel is set to Talk & Force Listen

When in a channel, the radio is accessible to other endpoints on the Arcadia system, for example, FreeSpeak and HelixNet.

IV direct port VR-Radio and 4W port Real-Radio are put in a channel together

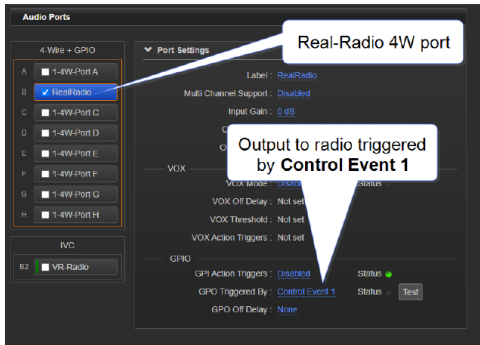

8.5.1 Step-by-step configuration of GPIOs with I.V. Direct (example)

Assume an I.V. Direct port is already configured and connected.

Arcadia: Assign the I.V. Direct port to a channel and configure GPO for this port.

1. Navigate to **Configuration > Channels** and put AR-Radio in a channel with the Arcadia.

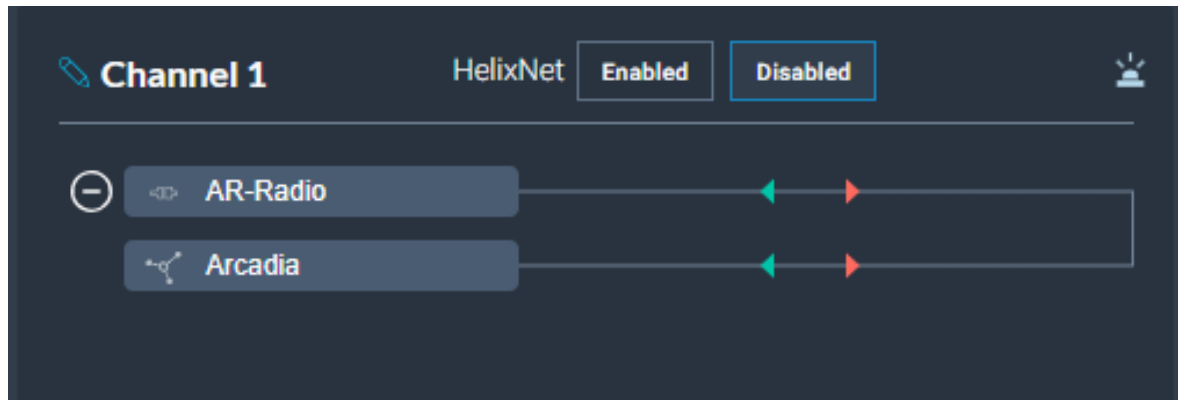

2. Navigate to **Configuration > Roles** [select Arcadia] and set the key activation type as **Talk and Forced Listen** (**Talk** or **Talk and Listen** can also be used)

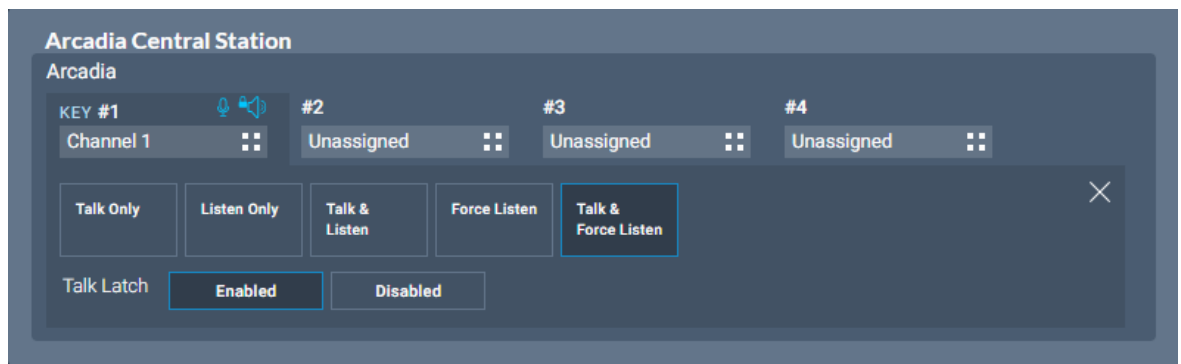

3. Navigate to **Configuration > Logic** and select the GPO for AR-Radio.
4. Click the blue + sign to create a new logic trigger.
5. Select the channel that contains the I.V. Direct as the **Key Target**.
6. Select the behavior that will trigger the GPO, in this case, **Talk-Only**. Click the blue

checkmark to complete the configuration.

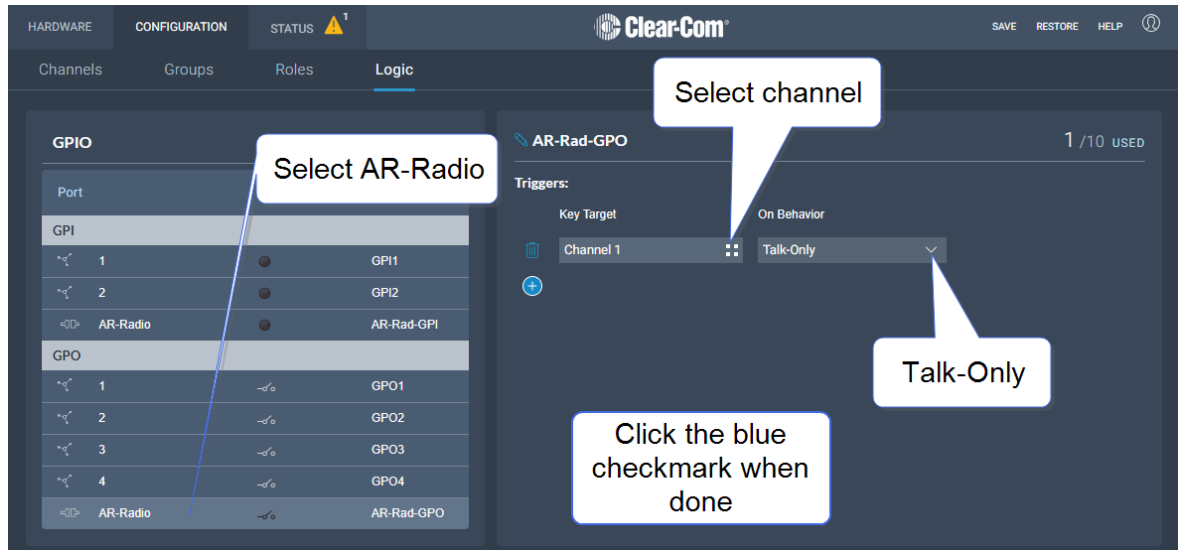

Note:

GPO Talk & Listen behavior is only for use with FreeSpeak Talk & Listen or Dual Talk & Listen key activations on a single button. Talk-Only is for use with Arcadia, FreeSpeak and HelixNet keys using all other types of Talk activations.

LQ: Assign I.V. Direct port and the 4W port that the radio is connected to in a channel and set GPIO (control events) on each port.

1. In the LQ CCM, navigate to Assignments and associate VR-Radio and Real Radio to a common channel.



2. Navigate to **Device > Ports** and select the 4W port that the radio is connected to (RealRadio).
3. Set the GPO trigger to Channel Event 1.

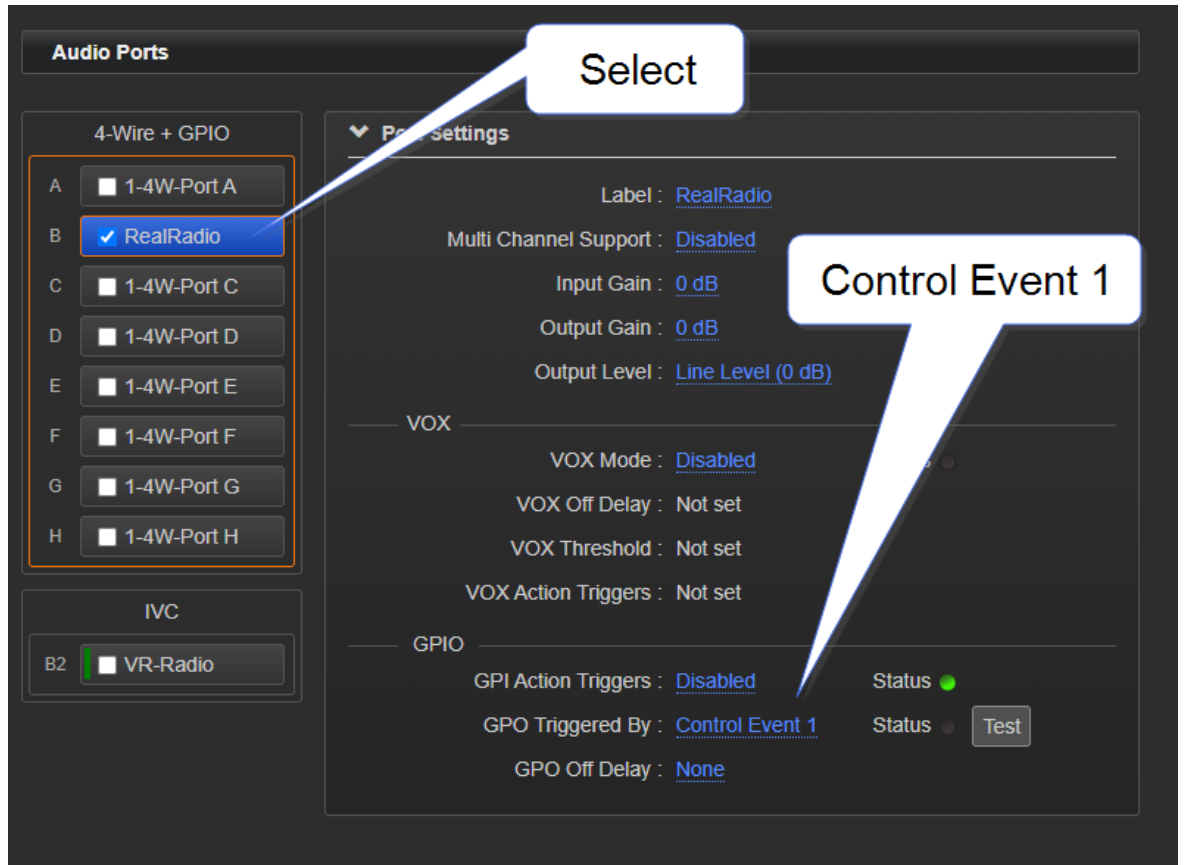

4. Select the I.V. Direct port (VR-Radio).
5. Set the GPI trigger to Control Event 1.

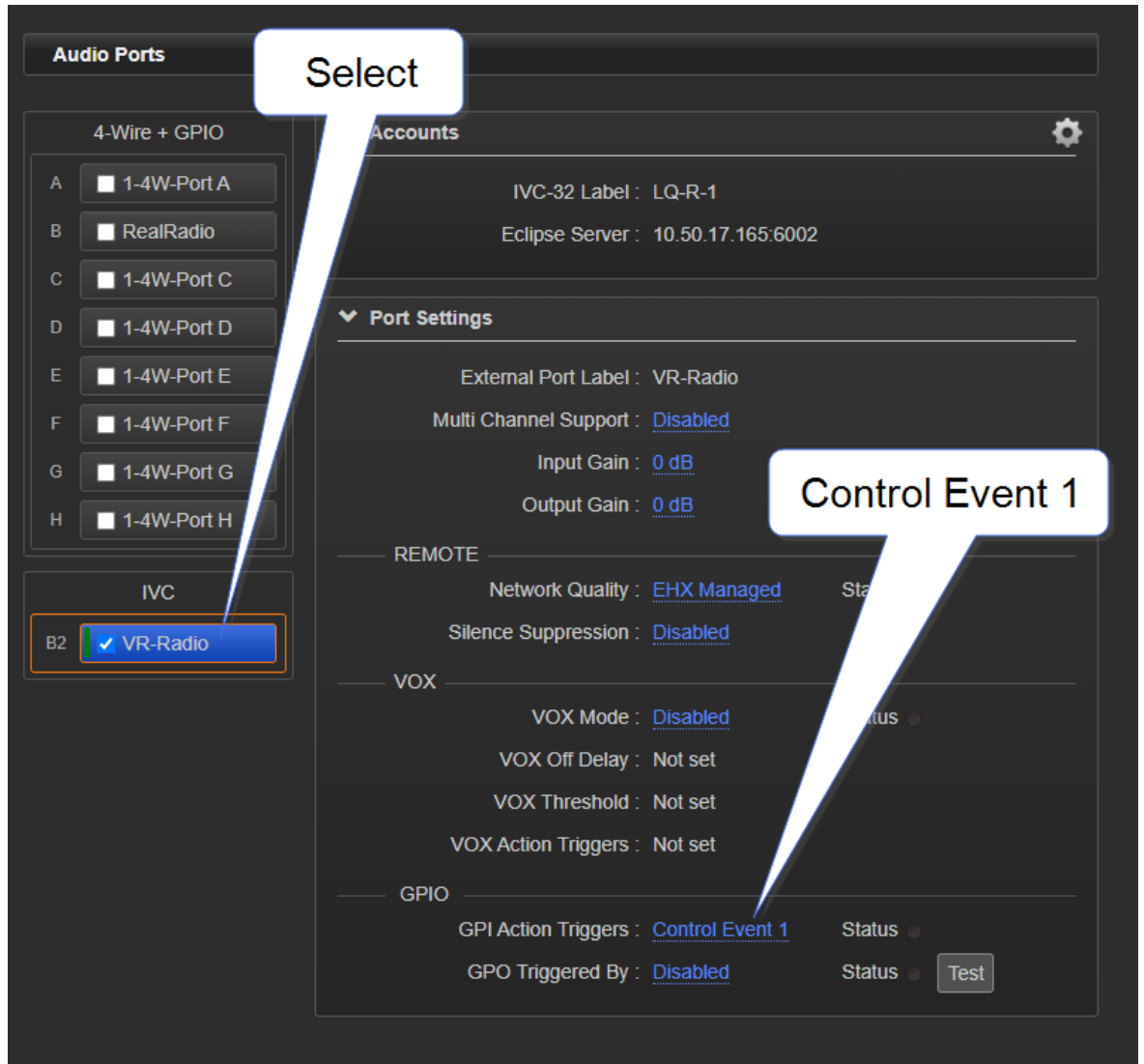

- Once the GPIO has been set up, you can see the Channel Event 1 signal in the Assignments page in the LQ CCM when a Talk comes into Channel 1 and activates the GPO to the radio.

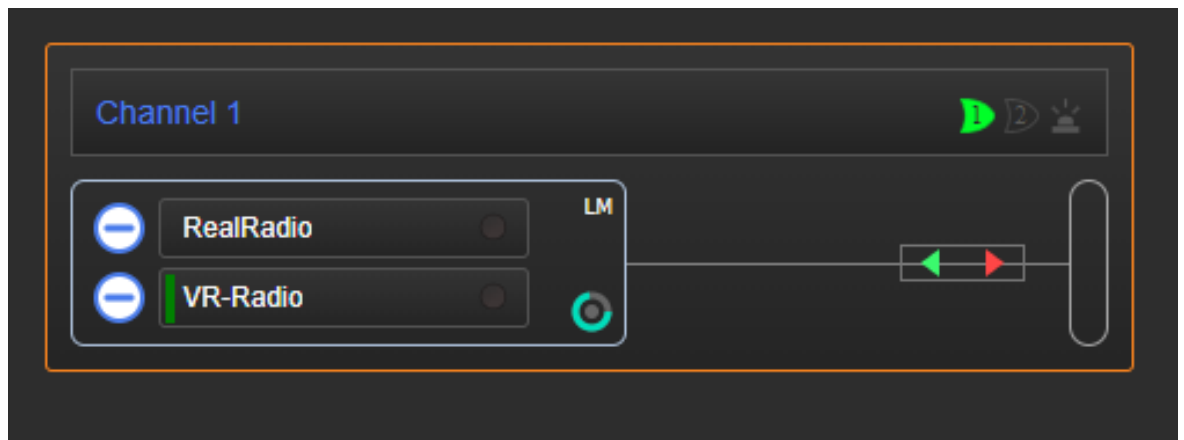

9 Using Dante Systems

To configure Dante you must be familiar with the Audinate Dante Controller, available from the Audinate website.

Before configuring the connection in the Dante Controller, you must determine which of the 4 LAN connectors on the Arcadia you wish to use for Dante network traffic.

Note: *The PC running the Audinate Dante Controller must be connected to the Dante network.*

Note: *The Dante connection on the Station supports Dante and Dante AES67 audio interfacing.*

Determining which LAN connector you wish to use for Dante must be done in the CCM.

Navigate to **Hardware > Host**. Under the **Network** tab, select the port for Dante. This port will default to a DHCP setting. If you wish to configure a static IP address you must do this in the Dante controller.

The screenshot displays the Clear-Com CCM interface for configuring a host device. The top navigation bar includes 'HARDWARE', 'CONFIGURATION', and 'STATUS'. The 'Host' page is selected, showing 'Resources' and 'Host Device' details. The 'Host Device' section includes fields for NAME (ff080571), TYPE (FreeSpeak Edge Base Station), IP ADDRESS (11.11.11.30), CONNECTIONS (2W, 4W, DANTE, FSE, FSII), VERSION NUMBER (2.7.83.25), and POWER STATUS. The 'Network' tab is active, showing LAN 1 (Management), LAN 2 (AES67), and LAN 3 (Dante). A callout box points to the 'Dante' option for LAN 3 with the text 'Select Dante'. Below the LAN settings, the 'Dante' section shows 'Redundancy Mode' set to 'Secondary' and a warning message: 'Network configuration and Dante® cross-points need to be configured using the external Audinate® Dante® controller software. It has to be connected onto the primary DANTE® IP subnet to establish proper connection'. A callout box points to the 'Apply' button with the text 'Apply'.

Note: *LAN 3 and 4 are for use with an SFP module (either fiber or RJ45).*

Note: *You must have sufficient licensed ports; each Dante channel consumes one licensed port.*

LAN connectors can be configured in any way you wish, but the CCM enforces that you can not configure IP transceivers (AES67) and Dante traffic on the same network. This is because AES67 network traffic has different timing requirements than Dante network traffic for FreeSpeak IP transceivers.

Dante IP configuration is configured in the Dante Controller.

1. In the CCM, navigate to **Hardware > Host > Network** and configure Dante on the LAN connector you wish to use for Dante connections.
2. Connect a cable (Cat5/6e or fiber) to the LAN connector that is designated for Dante. Connect the other end to a switch on your Dante network.
3. Open the Dante Controller and check that the network interface details are correct.

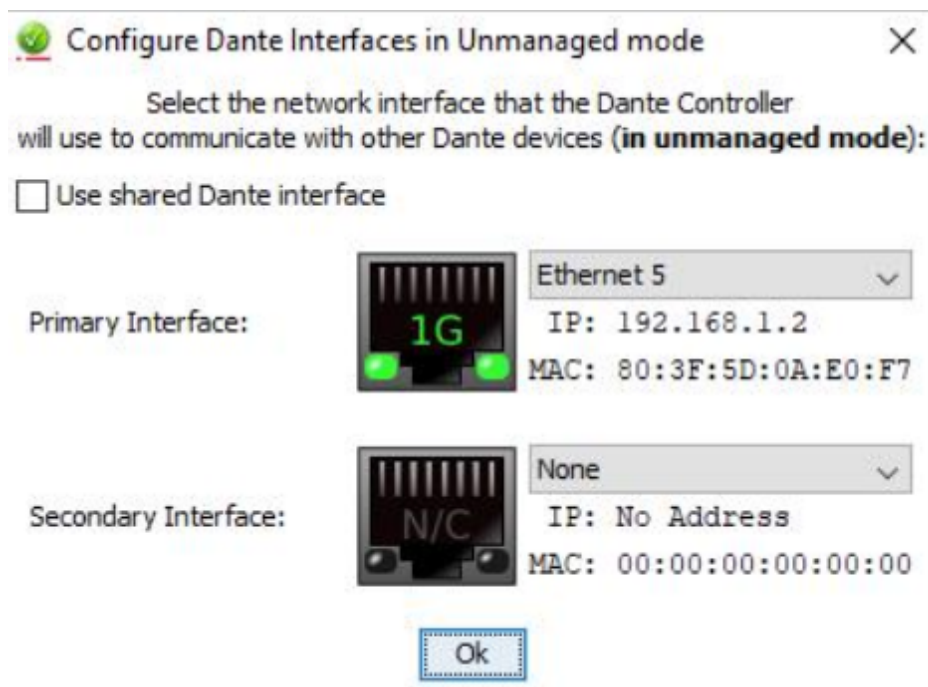

4. Check network and connection details under the **Status > Host Device** tab in the CCM.

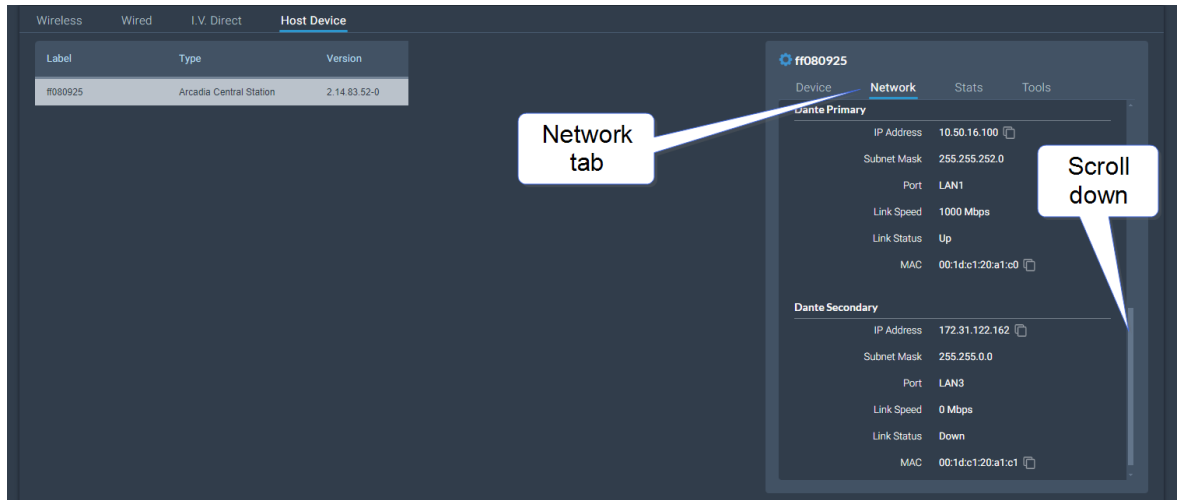

5. Details can also be viewed in the Dante Controller.

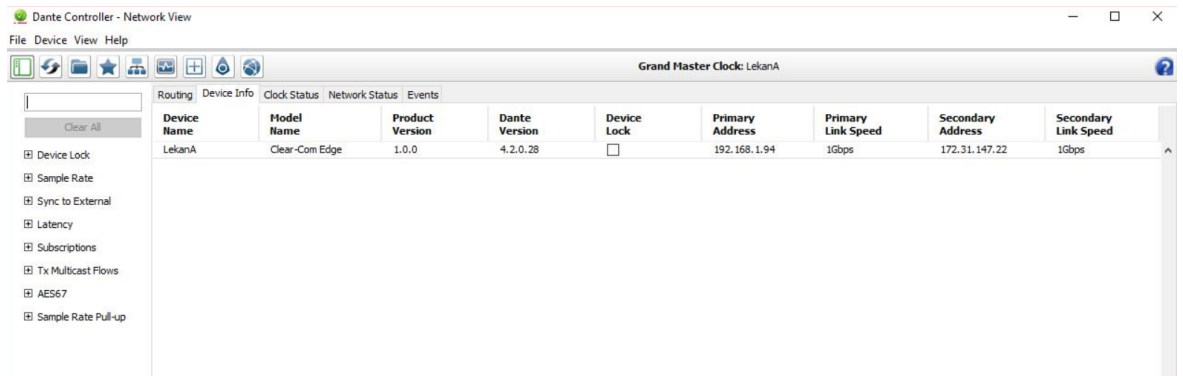

6. In the CCM navigate to **Hardware>Resources>Dante Ports** and add Dante ports. Give the new ports a suitable label.

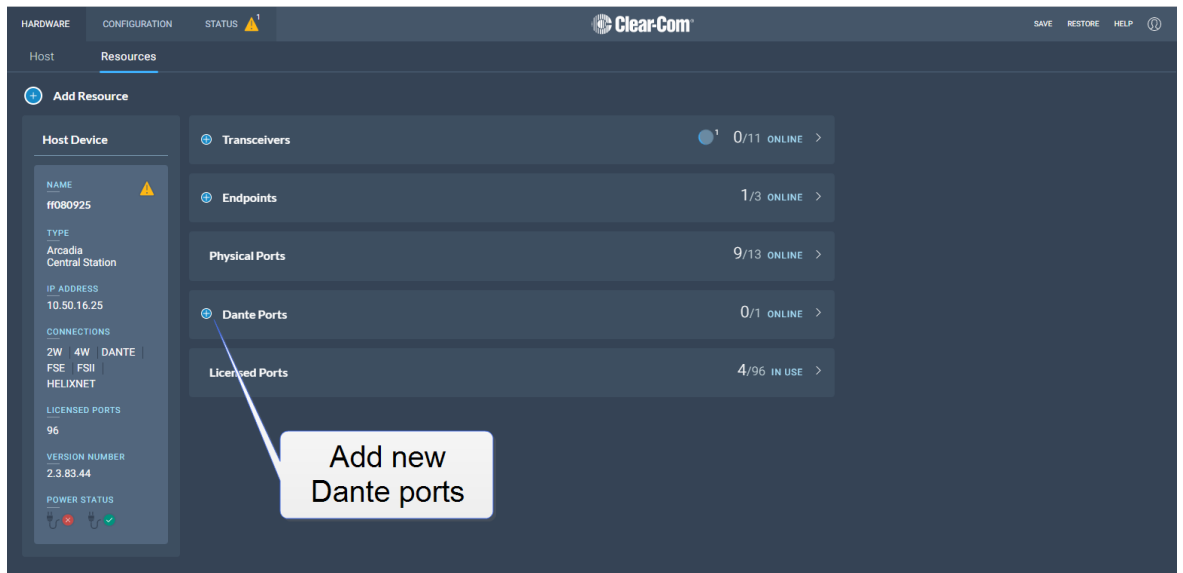

7. Route the channels as required in the Dante Controller.

- You will see available Dante ports in the **Configuration** page of the CCM. These ports can be assigned to channels on the Arcadia in the usual way.
- Select the required channel click the **+** icon next to the port.

The screenshot displays the Clear-Com CCM interface for channel configuration. The top navigation bar includes 'SYSTEM', 'SETUP', and 'STATUS'. Below this, there are tabs for 'Channels', 'Groups', 'Roles', and 'Logic'. The main area is titled 'Add Channel' and shows a table of channels, a diagram of 'Channel 1', and a list of available ports.

Channels (2/100 USED)

| Status | Id | Name | Online | Talkers |
|--------|----|-----------|--------|---------|
| ✓ | 1 | Channel 1 | 2/2 | 1 |
| ✓ | 2 | Channel 2 | 1/1 | 0 |

Channel 1

Dante P 1
Edge Base

Ports (1/20 ASSIGNED)

| Port | Port | Assignment |
|-----------|--------------|------------|
| 2W-Port A | 2W-Port A | None |
| 2W-Port B | 2W-Port B | None |
| 2W-Port C | 2W-Port C | None |
| 2W-Port D | 2W-Port D | None |
| 4W | | |
| 4W-Port1 | 4W-Port 1 | None |
| 4W-Port2 | 4W-Port 2 | None |
| 4W-Port3 | 4W-Port 3 | None |
| 4W-Port4 | 4W-Port 4 | None |
| 4W-Port5 | 4W-Port 5 | None |
| 4W-Port6 | 4W-Port 6 | None |
| 4W-Port7 | 4W-Port 7 | None |
| 4W-Port8 | 4W-Port 8 | None |
| Dante | | |
| Dante P 1 | Dante-Port 1 | Channel 1 |
| Dante P 2 | Dante-Port 2 | None |
| Dante P 3 | Dante-Port 3 | None |
| Dante P 4 | Dante-Port 4 | None |
| Dante P 5 | Dante-Port 5 | None |
| Dante P 6 | Dante-Port 6 | None |
| Dante P 7 | Dante-Port 7 | None |
| Dante P 8 | Dante-Port 8 | None |

A callout box with the text "Click here" points to the plus icon next to the first row in the Dante section of the ports table.

10 Using 2-Wire Systems

This chapter describes how to use the Arcadia Central Station with 2-Wire intercom devices. It contains the following sections:

| | |
|---|-----|
| 10.1 Introduction to 2-Wire Systems | 153 |
| 10.2 2-Wire Port Compatibility | 156 |

10.1 Introduction to 2-Wire Systems



- Power: Enabled/**disabled**
- Mode: **Clear-Com**/RTS
- Termination: Enabled/**disabled**
- Nulling: Start Nulling

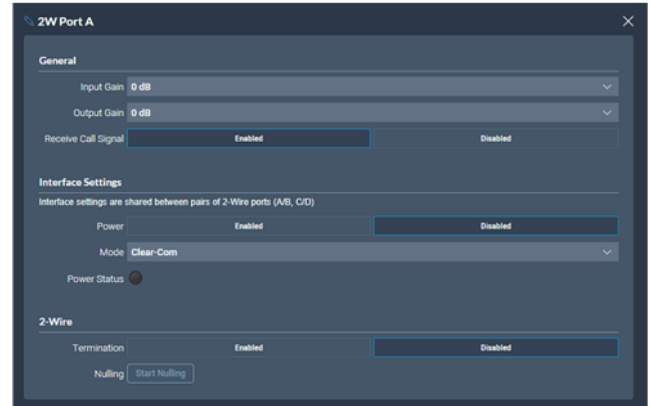

When connecting 2-wire equipment the following applies:

- **Terminate**
 - 2-wire partyline circuits must be terminated once on the line
 - Do not terminate on more than one device in the system
 - Enable/disable the termination. Default setting: **Disabled**
 - The Station default setting assumes the 2-wire partyline is nulled elsewhere in the system (i.e. at a partyline main station or power supply)

Line termination is set in the CCM only. To do this, in the CCM navigate to: **Hardware > Resources > Physical Ports**. See below

- **Power**
 - 2-wire partyline beltpacks can be powered by the Station 2-wire ports. Quantity of beltpacks and length of cable are variables, dependent on the type of devices and existing cabling
 - To calculate what will work best in your circumstances, see the *Encore Partyline Power Calculator*, available from the [Encore Knowledge Center](#)

- Enable/disable the partyline power. Default setting: **Disabled**
- The Station default setting assumes the 2-wire partyline is powered elsewhere in the system (i.e. using a partyline main station or power supply)

These functions can be set either in the 2-wire port settings page of the CCM or from the front panel menu on the Station

- **Null**

- 2-wire null serves the purpose of isolating audio that goes to the 2-wire partyline from the Station from the audio that comes from the 2-wire partyline to eliminate undesirable echo. The null is trained to the properties of the partyline cabling and equipment connected to the Station and varies depending on the setup
- Keep the following in mind for nulling:
 - Microphones on the 2-wire partylines should be unlatched
 - RMK before initiating the Null process
 - Ensure the 2-wire partyline is not in use
 - Null again if equipment or cabling is changed on the 2-wire partyline

- **Assign**

- 2-wire port may need to be assigned to channels or role keys as appropriate

To configure 2-wire port settings in the CCM navigate to: **Hardware > Resources > Physical Ports > (select port)** :

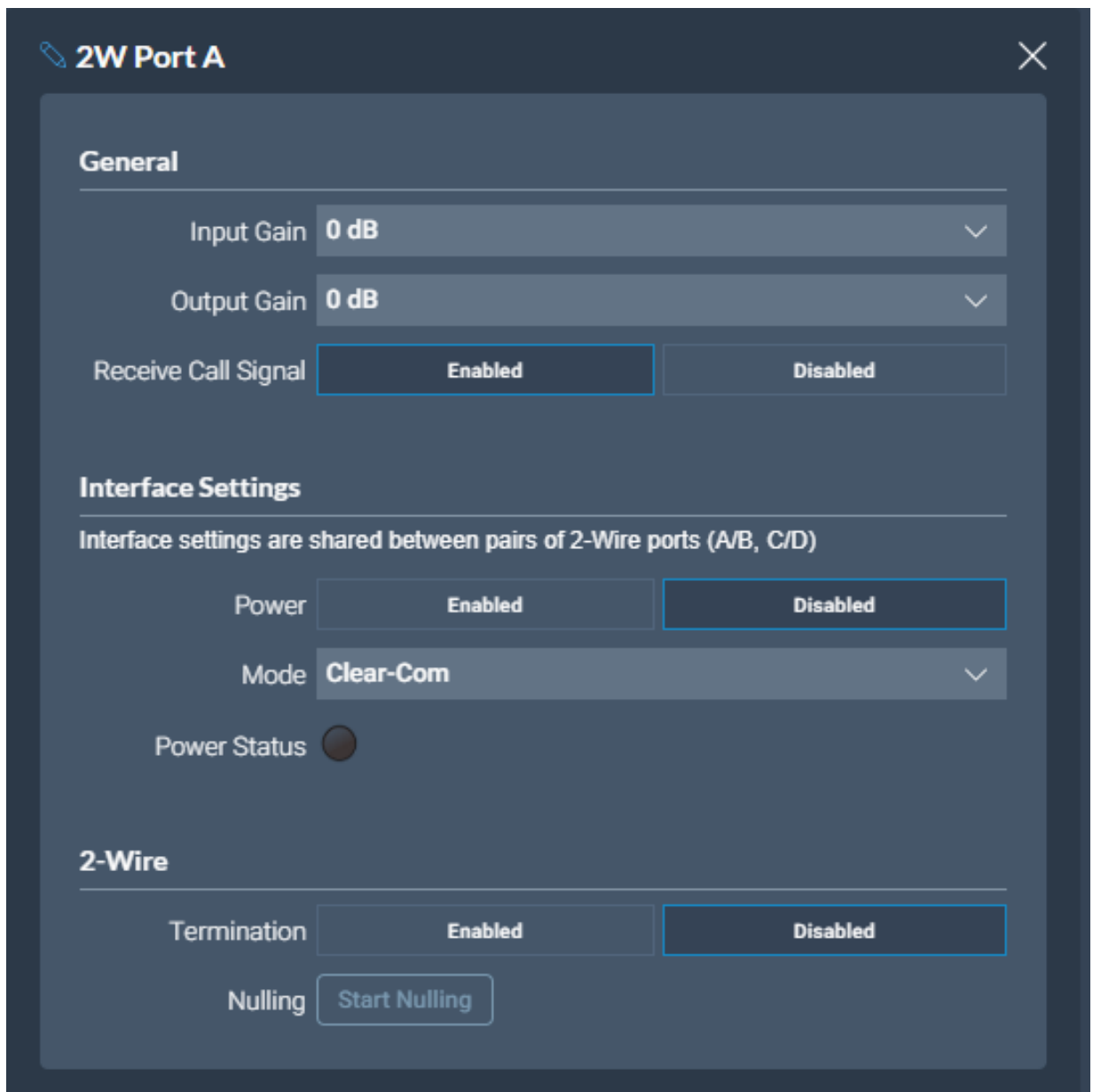

The screenshot shows the configuration window for '2W Port A'. It is divided into three main sections: General, Interface Settings, and 2-Wire.

- General**
 - Input Gain: 0 dB (dropdown menu)
 - Output Gain: 0 dB (dropdown menu)
 - Receive Call Signal: Enabled (radio button selected)
- Interface Settings**
 - Interface settings are shared between pairs of 2-Wire ports (A/B, C/D)
 - Power: Disabled (radio button selected)
 - Mode: Clear-Com (dropdown menu)
 - Power Status:
- 2-Wire**
 - Termination: Disabled (radio button selected)
 - Nulling: Start Nulling (button)

10.2 2-Wire Port Compatibility

When connecting Clear-Com Stations to other Clear-Com equipment and third-party systems (2-wire) use the following guidelines.

| Device Type | Supports call signalling? |
|---------------------------------------|--|
| HelixNet HLI-2W2* | Yes |
| Encore MS-702/4 | Yes |
| Encore RS Beltpack RS-701 / 702 / 703 | Yes |
| RTS 2-wire equipment | Yes, but does not pass call signalling to 4-wire audio routes. |
| FreeSpeak/FreeSpeak II Base II* | Yes |
| 2-way radio | Yes, via a TW-47 interface |

*Where there is a choice between a 2-wire and a 4-wire connection, 4-wire provides the best audio quality and is preferred.

11 Using 4-Wire Systems

This chapter describes how to use the Arcadia Central Station with 4-Wire intercom devices. It contains the following sections:

- 11.1 Connecting 4-Wire 158
- 11.2 Port Function (4-Wire Pinout) 162
- 11.3 Connecting 4-Wire Clear-Com to Clear-Com 163
- 11.4 Setting Port Function (Pinout) on a 4-Wire Connection 164

11.1 Connecting 4-Wire

When referring to intercoms, a four-wire circuit describes an intercom connection (I/O) where there are four wires (two paths) and the paths are different for talk and listen.

Analog or four-wire circuits use two pairs for balanced line-level audio signals, one for input and the other for output, using four wires in total.

Note: *A four-wire audio circuit is further defined by the attribute that the two paths can be used for unassociated signals. This means that the source input is not always associated with or routed to the destination output. This is commonly known as a four-wire split or split port. At the time of writing, a split port is only available on Eclipse-HX Digital Matrix products.*

Note: *To minimize noise and meet regulatory requirements, use screened (shielded) cable when connecting 4-wire ports.*

11.1.1 Connecting Audio - Non-Clear-Com to Clear-Com (4-Wire)

All Clear-Com four-wire audio ports are analog format line level (0 dBu nominal / 18 dBu max).

When connecting non-Clear-Com equipment to a Clear-Com device, the following is the correct default pinout of the four-wire port (RJ45) for input and output.

Note: *Except the Eclipse MVX-A16 interface card (input 3 & 6, output 4 & 5).*

| Pin | Use | |
|-----|-------------|---|
| 1 | n/a | <p style="text-align: center;">RJ45 Pinout T-568B</p> <p style="text-align: center;">1. White Orange 5. White Blue 2. Orange 6. Green 3. White Green 7. White Brown 4. Blue 8. Brown</p> |
| 2 | n/a | |
| 3 | Audio Out + | |
| 4 | Audio In + | |
| 5 | Audio In - | |
| 6 | Audio Out - | |
| 7 | n/a | |
| 8 | n/a | |

Note: Always read your 3rd party device manual before connecting to Clear-Com.

Note: The above diagram illustrates the default pinout mode for Clear-Com RJ45 : 4-wire-X. See **Port Function** for details.

XLR Breakout Cable Termination to RJ45 4-Wire

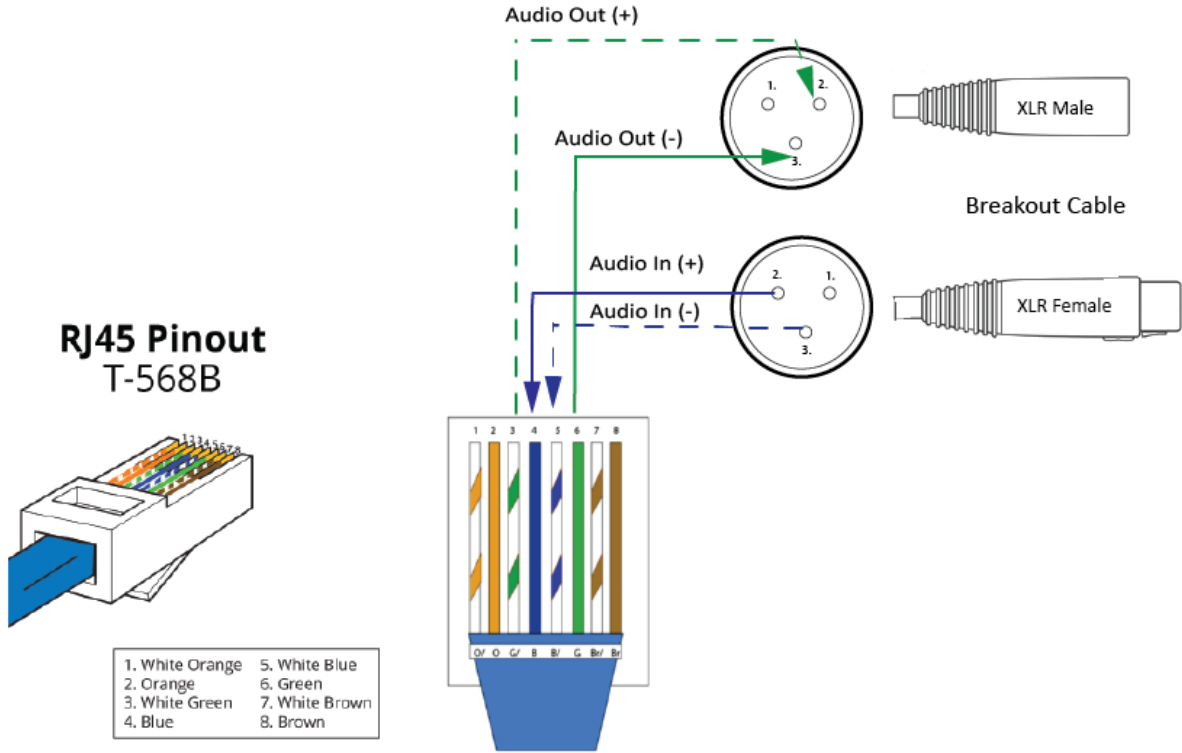

A breakout cable is supplied with the Arcadia and Edge stations. For other connections you need to make your own cable.

CAB-RJ45-PGM-SA - Four-Wire Analog Audio Splitter Cable - PGM/SA with RJ45 to 3-pin XLR-F & 3-pin XLR-M.

XLR Panel Termination to RJ45 4-Wire

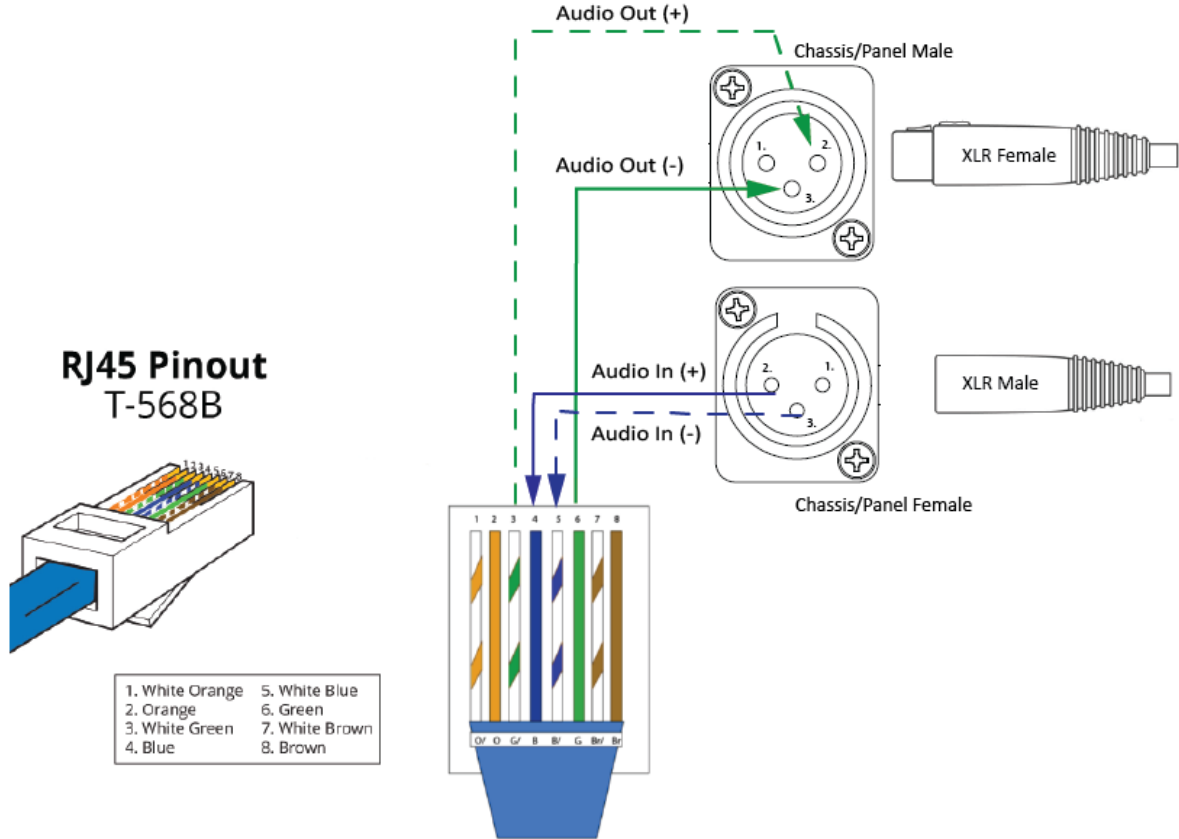

11.2 Port Function (4-Wire Pinout)

Some 4-wire RJ45 connectors on Clear-Com products include a software configuration that switches audio I/O pin configuration according to the device you are connecting to. This means that when connecting to Clear-Com devices, a cross-over cable is not necessary.

Clear-Com devices can have the following RJ45 4-wire pinouts:

- Clear-Com **4-Wire (To Panel)** on older systems)
- Clear-Com **4-Wire -X(To Matrix)** on older systems)
- Configurable, (either pinout is possible, according to the **Port Function** toggle switch).

To set the **Port Function** toggle, go to **Port Options** in the CCM or the device front panel menu system.

11.2.1 RJ45 Pinouts (Port Function Toggle)

| Pin No | 4-wire (To Panel) | 4-wire-X (default) (To Matrix) |
|--------|----------------------|-----------------------------------|
| 1 | Data in + | Data out + |
| 2 | Data in - | Data out - |
| 3 | Audio in + | Audio out + |
| 4 | Audio out + | Audio in + |
| 5 | Audio out - | Audio in - |
| 6 | Audio in - | Audio out - |
| 7 | Data out + | Data in + |
| 8 | Data out - | Data in - |

11.2.2 Clear-Com RJ45 4-Wire Pinout type by Device

| Device | Clear-Com RJ45 pinout type on this device (Port Function) |
|---|---|
| FreeSpeak II | 4-wire-X (fixed) |
| HelixNet HLI-4W2 | 4-wire-X (fixed) |
| HME DX200/DX210/DX410 | 4-wire-X (fixed) |
| Eclipse MVX-A16 | 4-wire (fixed) |
| FreeSpeak II Base II | Configurable. Default setting is 4-wire-X |
| FreeSpeak Edge Base Arcadia Central Station | Configurable. Default setting is 4-wire-X . |
| LQ Series | Configurable. Default setting is 4-wire-X |

11.3 Connecting 4-Wire Clear-Com to Clear-Com

When connecting Clear-Com to Clear-Com, one device must be in **4-wire** mode and one device must be in **4-wire-X** mode if you wish to use a straight-through cable.

11.3.1 Example: Arcadia Central Station to HelixNet Main Station

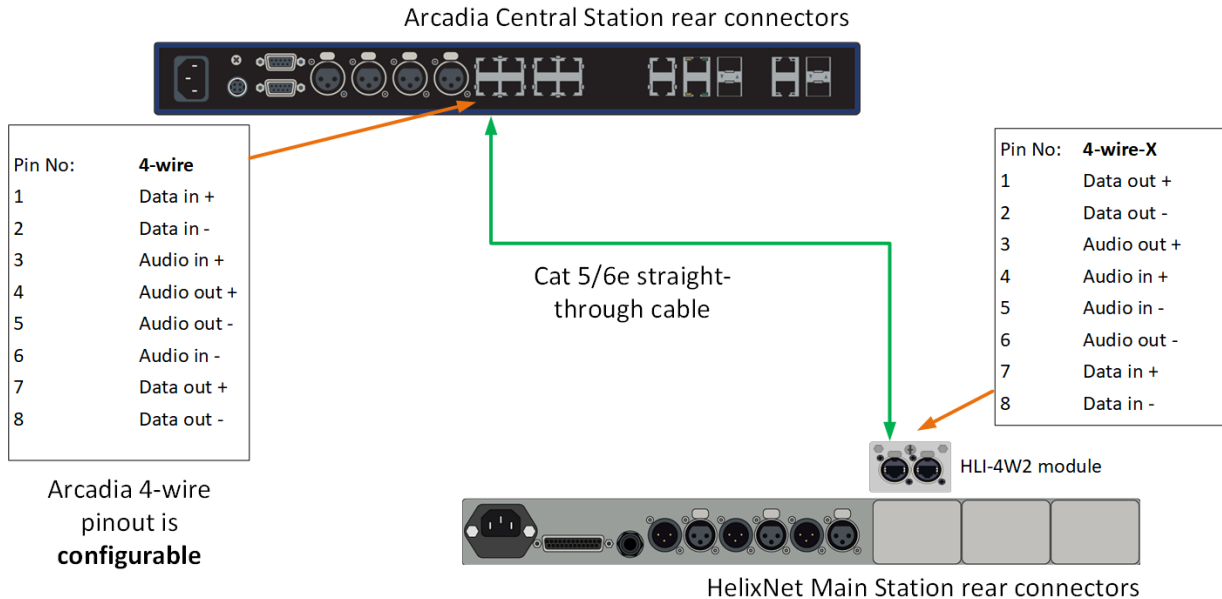

11.3.2 Example: 4-Wire RJ45 port 8 on Edge and Arcadia Stations - PGM and SA

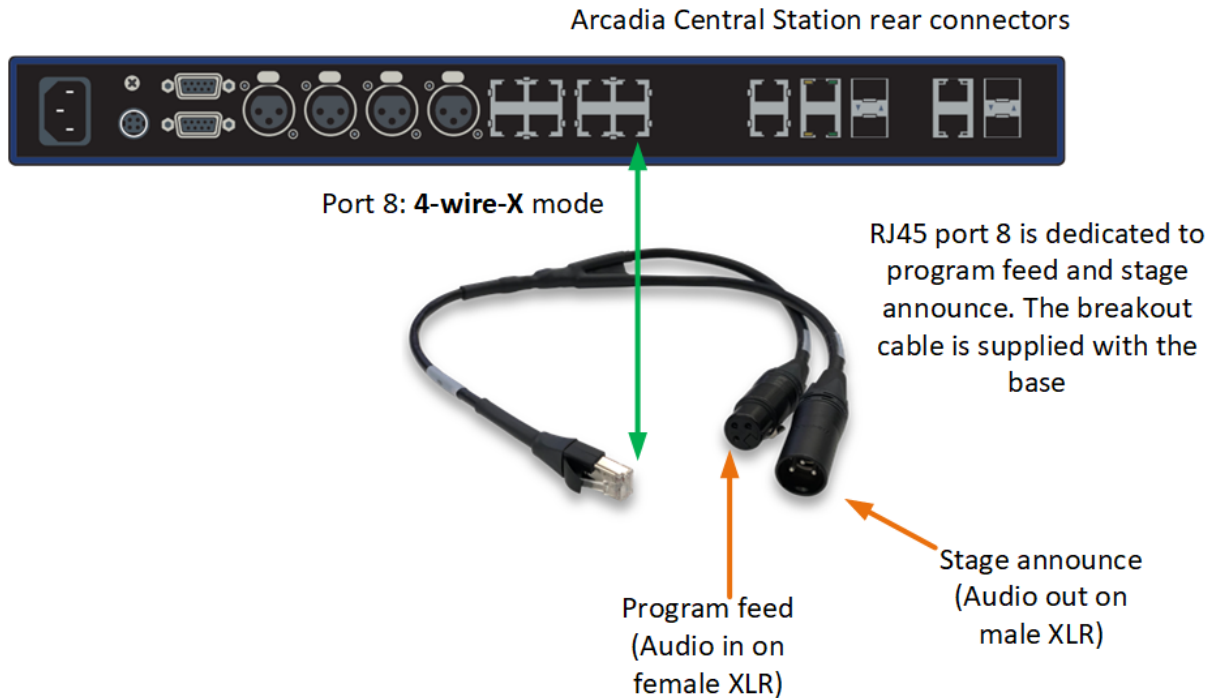

11.4 Setting Port Function (Pinout) on a 4-Wire Connection

1. Connect the devices using 1:1 Cat5/6/6e cable.
2. In the CCM, navigate to **Hardware > Resources > Physical Ports**.
3. Select the 4-wire port.
4. Select **Port Function**.

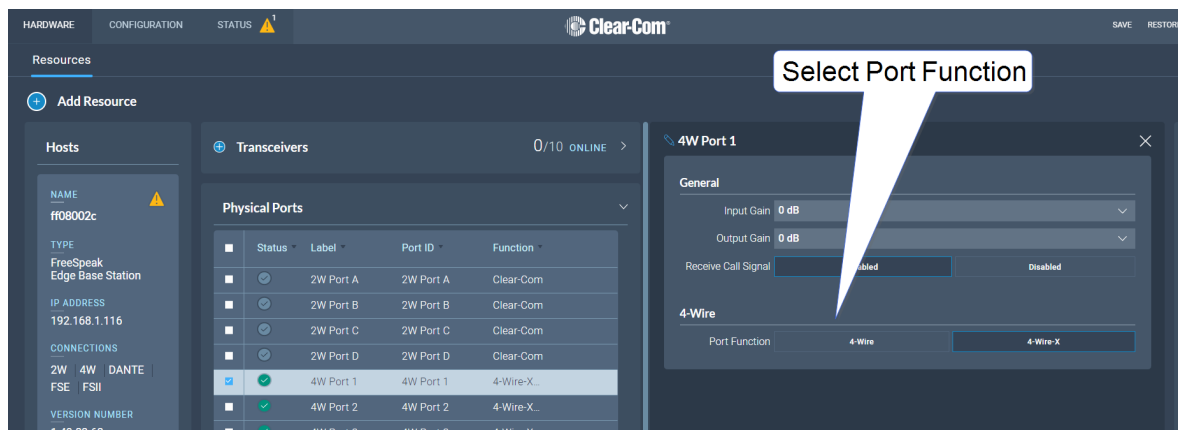

12 Upgrading Firmware

This chapter describes how to upgrade the firmware on your Station. It contains the following sections:

- 12.1 Introduction 166
- 12.2 Upgrading using the CCM 166
- 12.3 Upgrading using a USB Stick 166
- 12.4 HelixNet Upgrade 167

12.1 Introduction

There are two ways to upgrade the firmware on the Arcadia:

- Using the CCM web interface. When upgrading from the CCM, you can upgrade all connected resources (for example, transceivers and beltpacks).
- Using a USB stick (USB A on the front of the Arcadia). When upgrading in this way, only the Arcadia can be upgraded.

| Device to upgrade | File extension |
|---|------------------------------|
| Arcadia, FS II IP TCVR, FS Edge IP TCVR | .ccf |
| FS II beltpack, FS II E1 TCVR | .fww |
| FS Edge beltpack | .ccu |
| HelixNet | See Upgrading HelixNet below |

12.2 Upgrading using the CCM

1. In the CCM, navigate to **Hardware > Host > Upgrade**.
2. Press **Select File** and select the file containing the updated firmware.
3. When the file is uploaded, the **Upgrade** button will be enabled.
4. Press the **Upgrade** button.
5. The upgrade process will start and the Arcadia will reboot before being available again.
6. The new version of the firmware will be displayed in the **Hosts** panel.

12.3 Upgrading using a USB Stick

1. Copy the firmware file onto a USB stick. The file must be at the top level of the USB drive, not within any folders.
2. Insert the USB into the USB port on the front of the Arcadia.
3. Press the **Menu** button.
4. Using the rotary controllers, navigate to **Administration > Software > Update**.
5. The display will show the available firmware files stored on the USB. Select the one you require.
6. Press the 4th rotary encoder. The unit will upgrade and then reboot.

7. To check the current firmware version, in the menu system navigate to **Administration > Software > Current**. The current software version is displayed in the 4th menu screen.

12.4 HelixNet Upgrade

Upgrades to the HelixNet system are included with the Arcadia software. The HelixNet system requires that all connected devices have the same firmware. Therefore, any mismatches that are detected will cause an immediate and automatic upgrade (or downgrade) to the HelixNet devices on connection. The HelixNet system will also upgrade automatically when the Arcadia Central Station is upgraded.

13 Licensing

This chapter describes how to upgrade your Arcadia Central Station license. It contains the following sections:

- 13.1 Licensed Ports 169
- 13.2 Online Activation of Additional Licenses (Recommended) 169
- 13.3 Offline Activation of Additional Licenses 171

13.1 Licensed Ports

The Arcadia Central Station is available with licensed port capacity as best fits your needs:

- 16 ports
- 32 ports
- 48 ports
- 64 ports
- 80 ports
- 96 ports
- 112 ports
- 128 ports
- 144 ports
- 160 ports
- 168 ports

You can purchase additional licensed port capacity in 8 or 16-port bundles to a maximum of 168 ports.

When you purchase licensed port upgrades you will receive a **License Ticket ID** for your licenses that can be activated in the CCM of your Arcadia Central Station.

13.2 Online Activation of Additional Licenses (Recommended)

Note: *You can activate licenses online if your PC and Arcadia Central Station have an Internet connection on the same network.*

1. Navigate to **Hardware > Resources > Host > License**, and select **Add licenses online**.

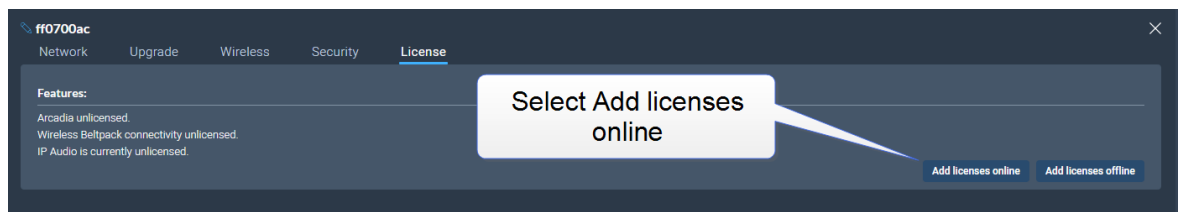

2. Enter the ticket you received from Clear-Com, and then select **Validate**.

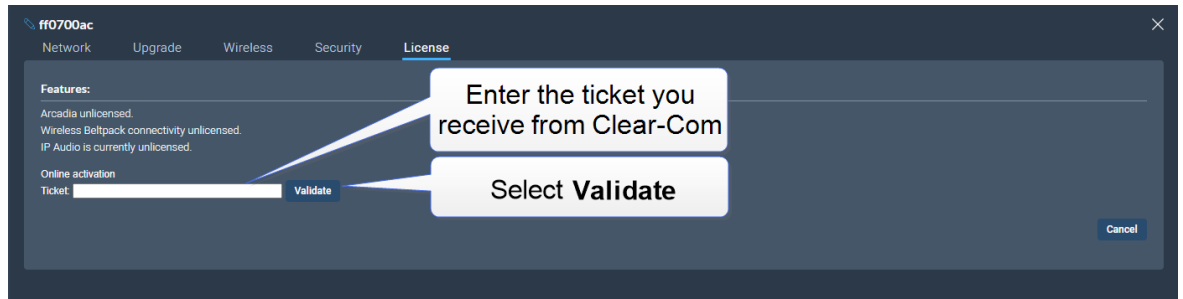

3. Click the checkbox, select the quantity of 8 or 16-port bundles of licensed port upgrades you wish to install and select **Activate**.

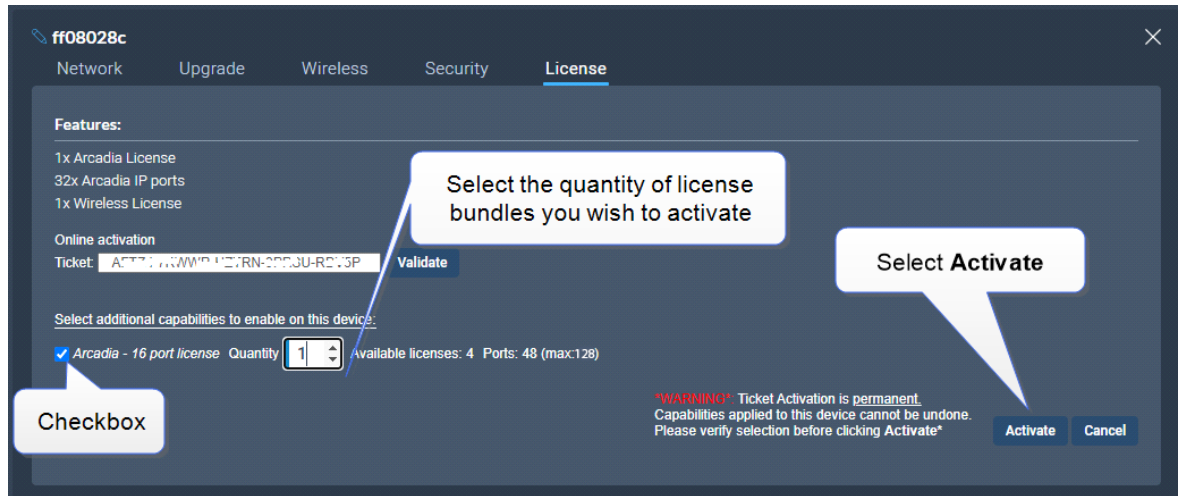

4. You must reboot the Station before the licenses take effect. In the CCM, navigate to **Status > Overview > Host Device** and select **Reboot**.
5. Once the licenses are activated, you will be able to see how many licenses you have in the **Hardware > Resources** page under **Licensed Ports**.

13.3 Offline Activation of Additional Licenses

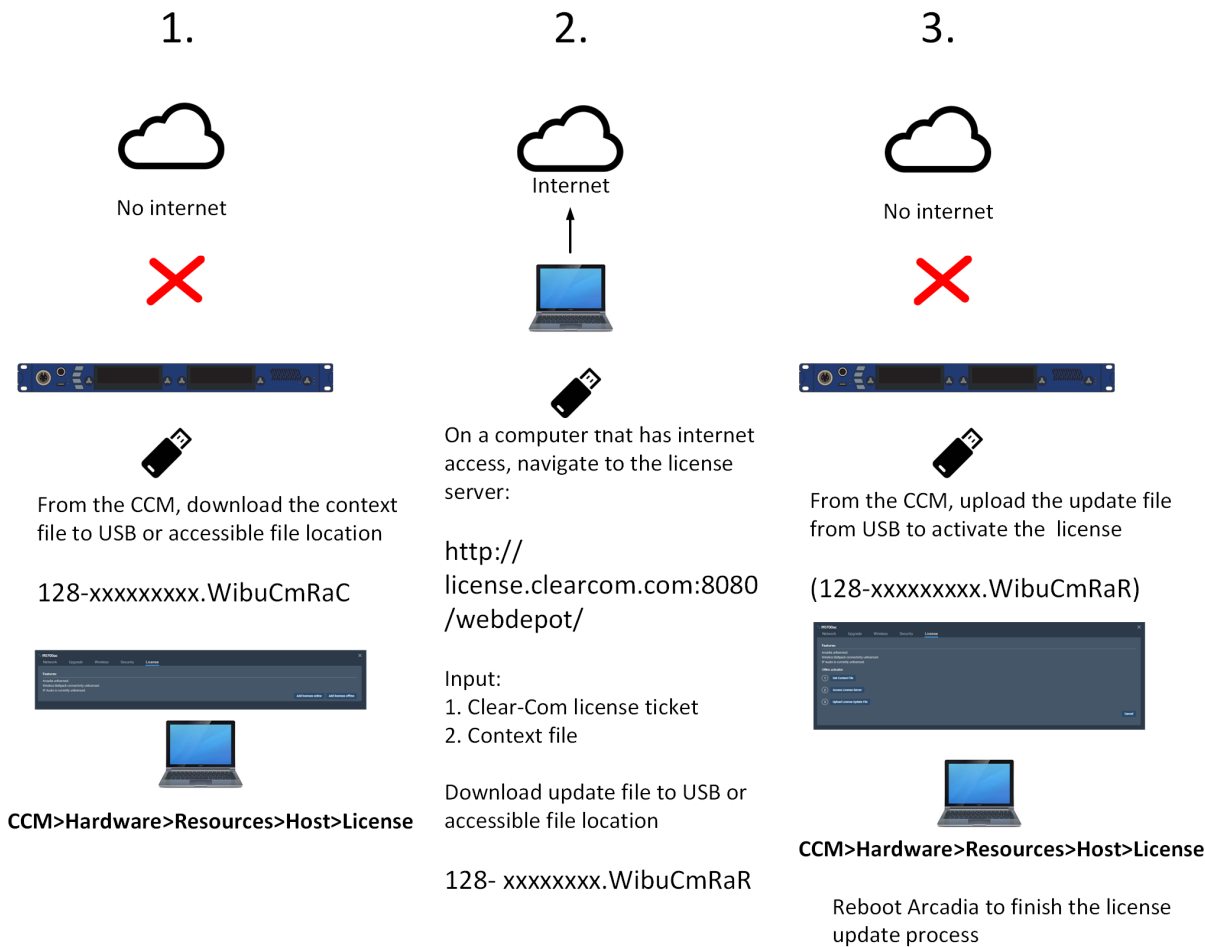

For detailed steps see below.

- 1. Navigate to **Hardware > Resources > Host > License**, and select **Add licenses offline**.

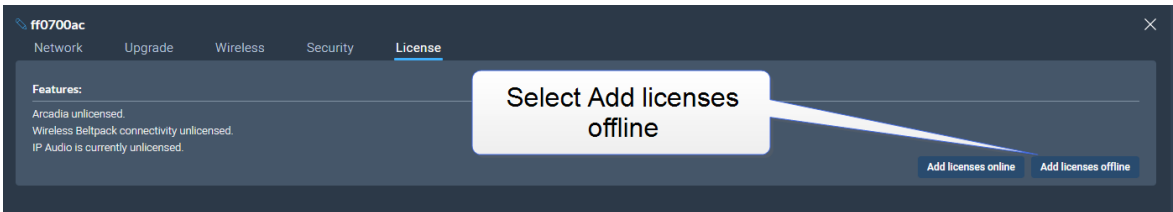

- 2. Select **Get Context File**.

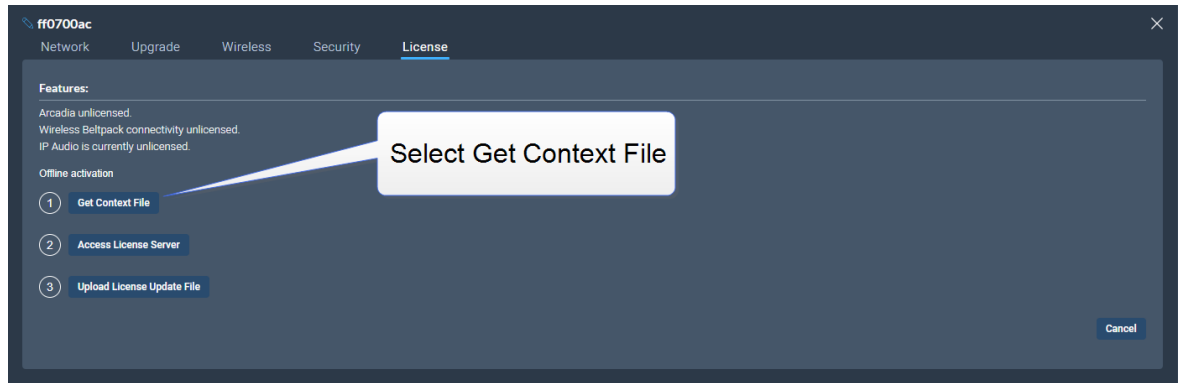

The context file downloads locally.

3. Use another PC which has internet access and connect a browser to <http://license.clearcom.com:8080/webdepot/>. As you will download the licenses into the previously downloaded context file (step 2) you need the context file on the new PC.
4. You will see the online license server. Enter your Clear-Com ticket number, and then Click **Next**.
5. The licenses on your ticket are displayed on the screen. Select **Activate Licenses**.

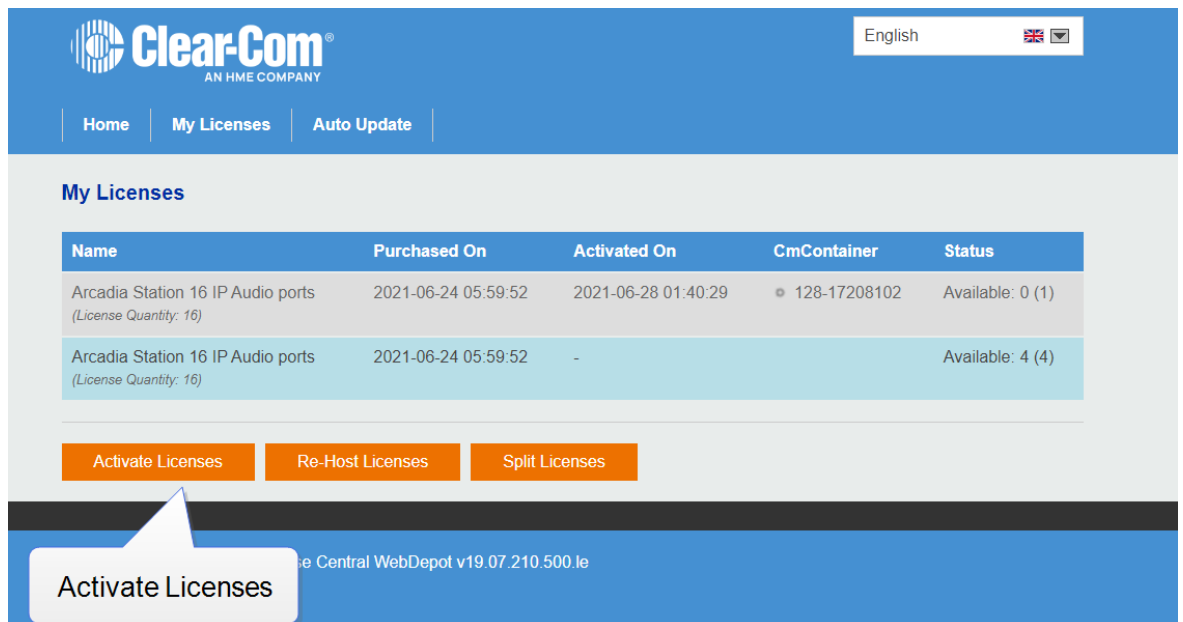

6. Select the left-hand option.

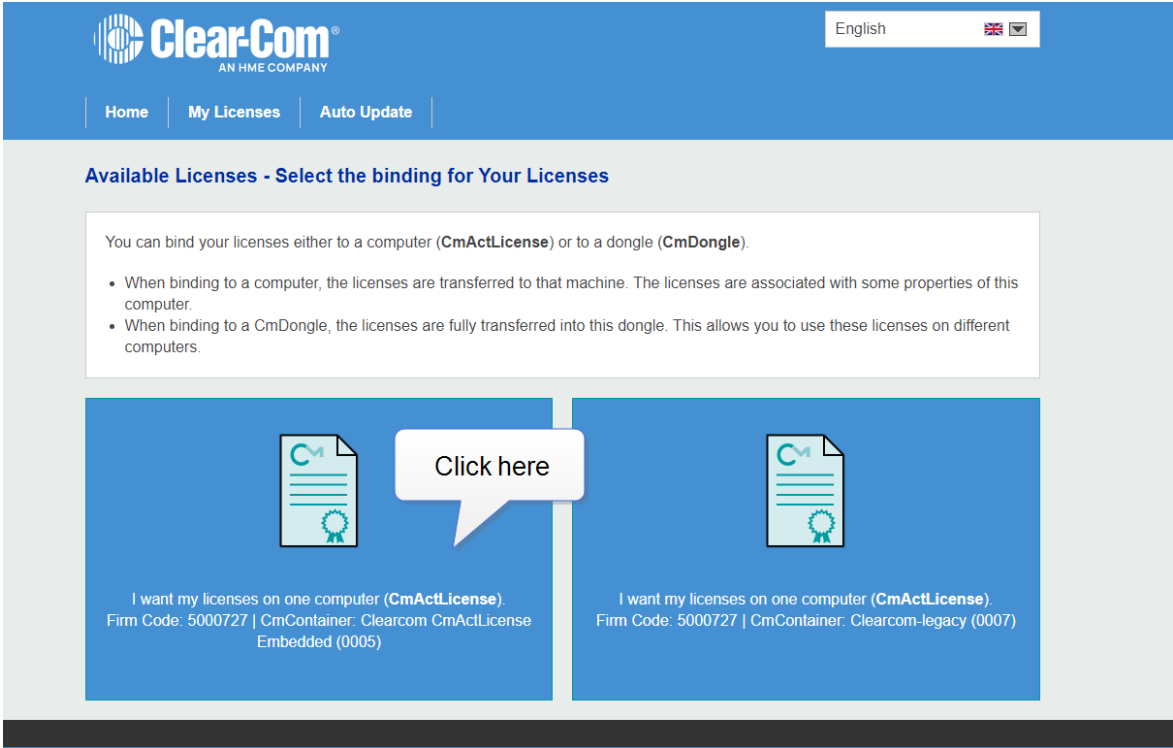

7. Click **File-based license transfer**.

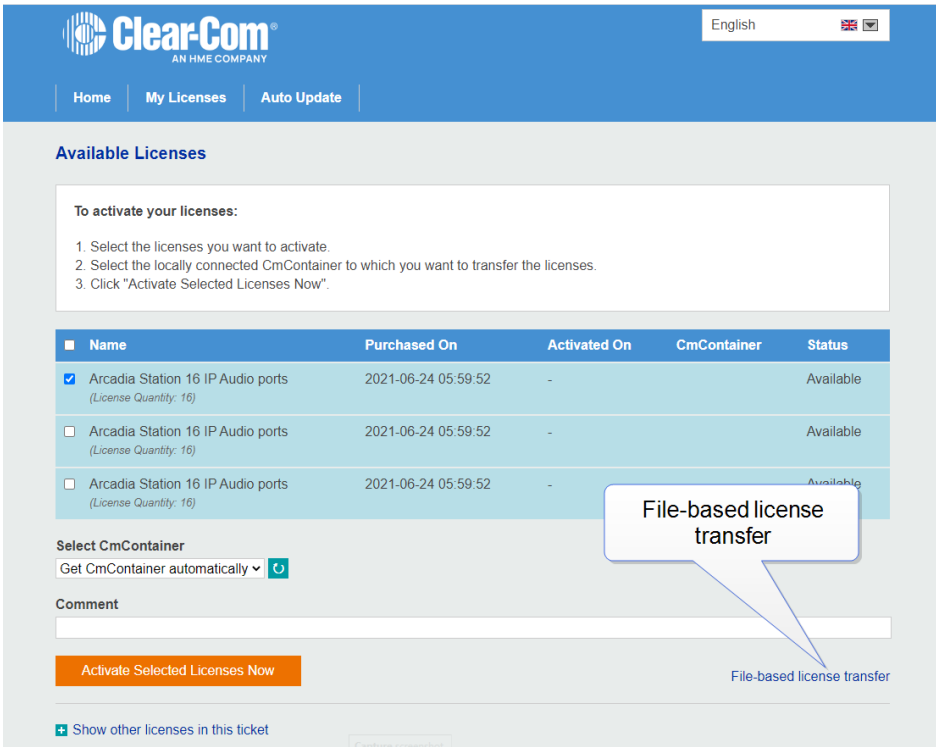

8. Select the required license(s). Click Choose File and navigate to the context file (downloaded in step 2). Select it. Then click **Start Activation Now**.

The screenshot shows a license management interface. At the top, a table lists licenses with columns for Name, Purchased On, Activated On, CmContainer, and Status. The first row is selected. Below the table, there are options to select an already used CmContainer or to pick a license request file. A 'Start Activation Now' button is at the bottom left, and a 'Direct license transfer' link is at the bottom right. Three callout boxes provide instructions: 1. Ensure license is selected (pointing to the first row), 2. Navigate to the previously downloaded context file and select it (pointing to the 'Choose File' button), and 3. Start Activation Now (pointing to the 'Start Activation Now' button).

| Name | Purchased On | Activated On | CmContainer | Status |
|--|---------------------|--------------|-------------|-----------|
| <input checked="" type="checkbox"/> Arcadia Station 16 IP Audio ports <i>(License Quantity: 16)</i> | 2021-06-24 05:59:52 | - | | Available |
| <input type="checkbox"/> Arcadia Station 16 IP Audio ports <i>(License Quantity: 16)</i> | 2021-06-24 05:59:52 | - | | Available |
| <input type="checkbox"/> Arcadia Station 16 IP Audio ports <i>(License Quantity: 16)</i> | 2021-06-24 05:59:52 | - | | Available |

Select an already used CmContainer
No CmContainer selected ▼

or

Pick a license request file (*.WibuCmRaC) of another CmContainer
Choose File 128-17208102 (4).WibuCmRaC

Comment
[Text Area]

Start Activation Now Direct license transfer

9. Download the License Update File
10. Do not **Upload Receipt Now**. Instead, return to the CCM and select **Upload License Update File**.
11. Navigate to where you have stored the downloaded file from Step 9 (128-xxxxxxx.WibuCmRaU). Select the file. The license will upload.
12. You must reboot the Station before the licenses take effect. In the CCM, navigate to **Status > Overview > Host Device** and select **Reboot**.
13. Once the licenses are activated, you will be able to see how many licenses you have in the **Hardware > Resources** page under **Licensed Ports**. You can also see licensed features on the **Hosts** panel in the same page.

14 Security

This chapter describes important security features. It contains the following sections:

- 14.1 Warning 176
- 14.2 Secure HyperText Transfer Protocol (HTTPS) 176
- 14.3 Using HTTPS 176
- 14.4 The Force HTTPS Feature 176
- 14.5 Forcing HTTPS 177
- 14.6 Using Security Certificates 179

14.1 Warning

The CCM ensures that you do not turn off port 80 without testing your certificate. If you turn off port 80 without ensuring that you can reach the CCM using port 433 it is possible to get locked out of your CCM. If this happens, you must reset the Arcadia from the front panel menus. This will remove all configuration, including network details from your Arcadia.

Note: *Some knowledge of certificate authorization and HTTPS is needed when setting up a secure connection between a PC hosting the Core Configuration Manager (CCM) and a Arcadia.*

Note: *Each browser type (for example, Safari, Chrome, Edge, Firefox) uses its own method for certificate management. These methods can change with time and is beyond the control of Clear-Com. Please refer to the instructions supplied with your browser if you require more information.*

The following are some of the main security features.

14.2 Secure HyperText Transfer Protocol (HTTPS)

HTTPS is an adaptation of the HTTP protocol. It protects against an intermediary being able to intercept data between devices, using data encryption and Public Key Cryptography to create a secured channel.

14.3 Using HTTPS

When using the CCM to establish your intercom setup, you might wish to protect your login credentials and configuration details from unauthorized interference. In this case you will establish an encrypted connection between the CCM and your Arcadia using the **Force HTTPS** feature.

14.4 The Force HTTPS Feature

The Arcadia uses port 80 (HTTP) and port 433 (HTTPS) for management. If you wish to create a secured route for data between the CCM and the Arcadia you must:

- Install a security certificate
- Turn off port 80, forcing traffic to use port 433

This creates a certified and encrypted connection between the Arcadia and the PC accessing the CCM.

14.5 Forcing HTTPS

1. Chose and install a security certificate on the PC or browser used to reach the CCM of the Arcadia. Clear-Com offers a choice of 3 different types of certificate, offering different levels of security.
2. Test the certificate by trying to reach the CCM on the HTTPS port. Type: **HTTPS:// device IP address** in the browser URL field and press the [Enter] key.

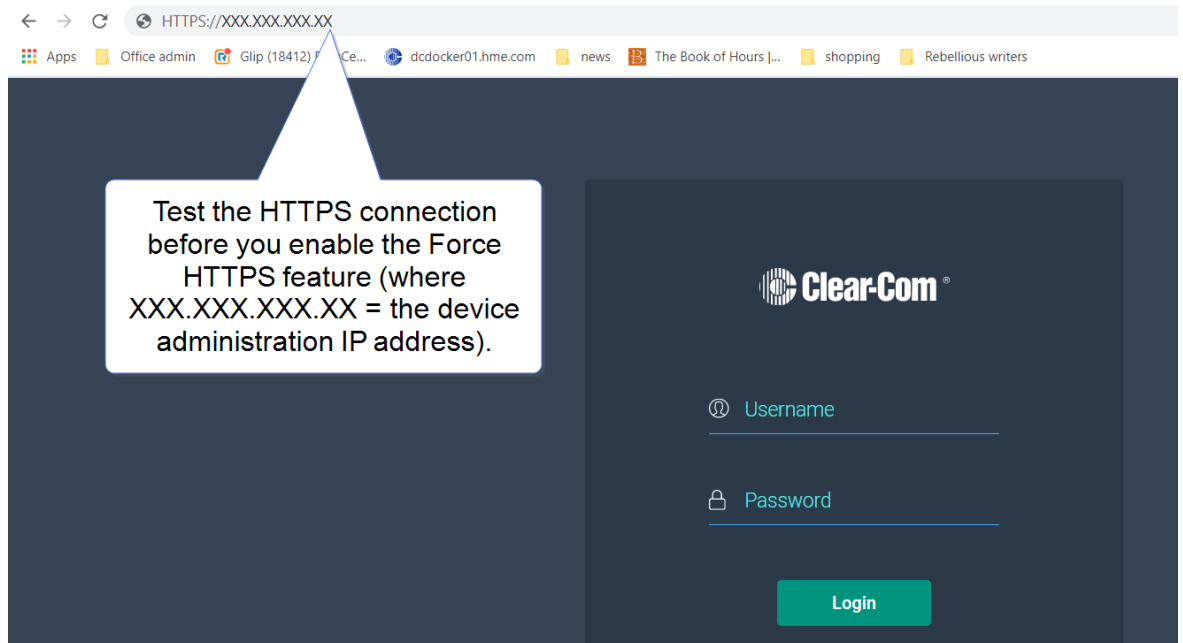

To enable **Force HTTPS** in the CCM navigate to: **Hardware > Resources > Host  > Security** and click to enable **Force HTTPS**. This turns port 80 off, forcing traffic to use port

433.

ff080238 [Close]

Network Upgrade Wireless **Security**

General

Info PLEASE CONNECT USING HTTPS BEFORE FORCING HTTPS. THIS IS TO ENSURE YOU WON'T HAVE CERTIFICATE VALIDATION ISSUES.

Force HTTPS Enabled Disabled

Default Certificate

The default certificate is used for internal traffic. Any other certificate loaded onto this unit will only be utilized for CCM.

Regenerate

Certificate Status **Valid**

Certificate Type **Self-signed**

Certificate Authority **Clear-Com**

Expiration Date **Jun 8 2023 --- 765 day(s) left.**

CA Certificate **Download**

Active Certificate

Use Default Certificate **Switch**

Use EasyDNS Certificate **Switch**

EasyDNS hostname cc-fsebase-31zyf587-0.clearcomdevices.com

14.6 Using Security Certificates

There are three types of security certificate available. Choose the certification option that best suits your security requirements:

- A certificate of your own choosing (full chain and private key)
- An EasyDNS authorized certificate for *.clearcomdevices.com (this option requires you to register your Arcadia with a DNS server) and cannot be used unless your Arcadia has internet access
- The Clear-Com self-signed certificate

More detail about certificates:

1. **A certificate of your own choosing.** This option gives you complete control over the security of your Arcadia. This option requires specialized knowledge about how to obtain a fullchain certificate and private key, and how to install them on your browser. When using your own certificate you might have to provide a DNS server address and register the Arcadia.
2. **The EasyDNS certificate.** This is a commercial certificate. When using the EasyDNS certificate you have to have a DNS server address for Arcadia registration and a gateway for your device in order for the browser to verify the certificate with AlphaSSL and GlobalSign.
3. **The Clear-Com self-signed certificate (default).** This certificate can be used in a private network (does not require Internet access to verify the certificate). It can also be used to perform an initial test of your security setup. **Warning:** Browsers can be configured to trust the self-signed certificate, but this process will vary between browsers.

15 Appendix A: Pinouts

15.1 GPIO pinouts

GPIO 1 (Relay 1 &2)



1. Relay 1 Common
2. Relay 1 Normally Closed
3. Relay 1 Normally open
6. Relay 2 Common
7. Relay 2 Normally Closed
8. Relay 2 Normally Open
4. Input A1
5. Input B1
9. 12V

Shield 0V

GPIO 2 (Relay 3 & 4)

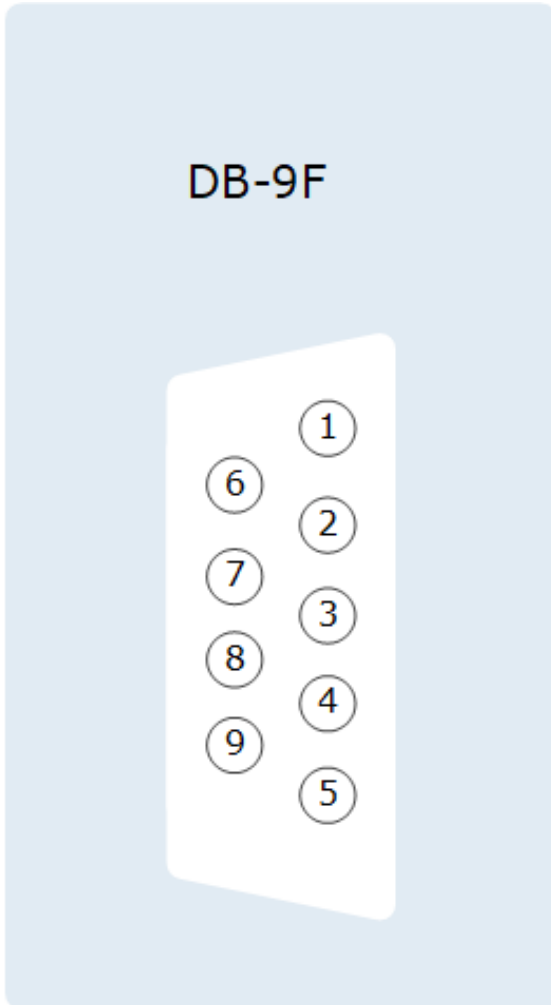

- 1. Relay 3 Common
- 2. Relay 3 Normally Closed
- 3. Relay 3 Normally open
- 6. Relay 4 Common
- 7. Relay 4 Normally Closed
- 8. Relay 4 Normally Open
- 4. Input A2
- 5. Input B2
- 9. 12V

Shield 0V

Suggested wiring for a footswitch

| From | To | |
|---------------------------|-----------------------|--------------------|
| GPIO-DB9 pin 4 (input A1) | GPIO-DB9 pin 9 (+12V) | link (jumper) wire |
| GPIO-DB9 pin 5 (input B1) | footswitch | |
| GPIO-DB9 Shell (0V) | footswitch | |

15.2 2-Wire Pinouts

15.2.1 Clear-Com 2-Wire XLR Pinout

- 1. Ground
- 2. DC power (30V)
- 3. Duplex audio

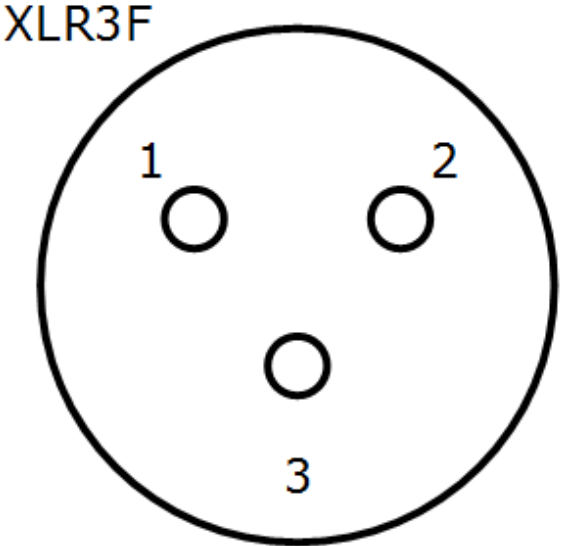

15.2.2 RTS 2-Wire XLR pinout

- 1. Ground
- 2. DC power (30V)
Duplex audio 1
- 3. Duplex audio 2

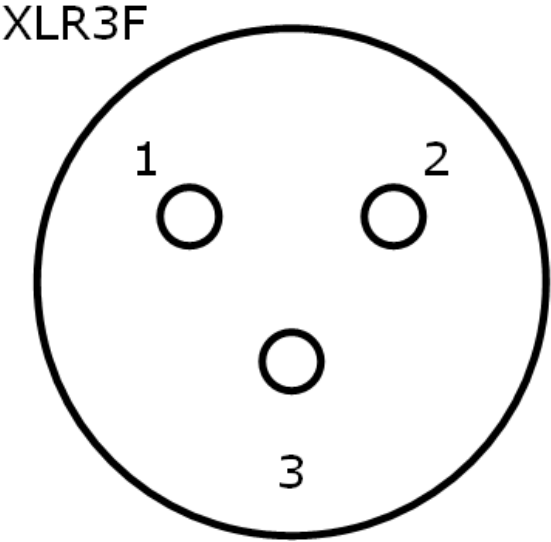

15.3 4-Wire Pinouts

| Pin | 4-wire | 4-wire-X (default) |
|-----|-------------|--------------------|
| 1 | Data in + | Data out + |
| 2 | Data in - | Data out - |
| 3 | Audio in + | Audio out + |
| 4 | Audio out + | Audio in + |
| 5 | Audio out - | Audio in - |
| 6 | Audio in - | Audio out - |
| 7 | Data out + | Data in + |
| 8 | Data out - | Data in - |

15.4 DECT Sync

| Pin | Sync In | Sync Out |
|-------|---------------|----------------|
| Pin 1 | DECTSYNC IN + | DECTSYNC OUT + |
| Pin 2 | DECTSYNC IN - | DECTSYNC OUT - |
| Pin 3 | 8 KHZ IN + | 8 KHZ OUT + |
| Pin 6 | 8 KHZ IN - | 8 KHZ OUT - |

Caution: Shielded Cable Requirement

Shielded Cable is required for ALL FreeSpeak and GPIO port connectivity. CAT 5e Shielded Cable must be used to assure compliance with domestic and international emissions standards. Customers, Installers and or qualified Personnel failing to use shielded cables may cause radio interference in which case the user may be required to take adequate measures.

16 Appendix B: Specifications

This chapter contains a list of technical specifications for the Station. It contains the following subsections:

| | |
|------------------------------------|-----|
| 16.1 Arcadia Central Station | 185 |
| 16.2 Capacity | 189 |
| 16.3 Network Specifications | 190 |

16.1 Arcadia Central Station

| Specification | Value |
|---------------------------------------|--|
| Front panel headset | (1) 4-pin XLR-M or 5-pin XLR-M <ul style="list-style-type: none"> • auto headset detect |
| Front panel headset microphone input | <ul style="list-style-type: none"> • Input type: Dynamic /Electret - Selectable • Frequency response: headset mic - Partyline: 200Hz – 12 kHz + 3dBu • Frequency response: headset mic - Line Out: 200Hz – 20 kHz + 3dBu • Mic limiter threshold: -50dBu ±3dB • Mic limiter range: ≥ 20dB • Max input level: -25dBu • Input level: -60dBu nominal; -25dBu MAX • Headset mic voltage 5V (Electret selectable) |
| Front panel headset microphone output | <ul style="list-style-type: none"> • Load Impedance: > 32Ω • Output Impedance: 33Ω • Max Output Level before Distortion: >13 dBu • Total Harmonic Distortion (THD): < 0.1% THD at 1 kHz • Headset Mic - Partyline: -78 dBu (Clear-Com mode) • Headset Mic - Line Out: -60 dBu • Frequency Response: Partyline - Headset Out: 200Hz – 10 kHz + 3dBu |

| Specification | Value |
|-----------------------------|---|
| Gooseneck microphone input | <ul style="list-style-type: none"> • Input type: Dynamic, Electret (selectable) • Frequency Response: Gooseneck Mic - Partyline: 200Hz – 12kHz + 3dBu • Frequency Response: Gooseneck Mic - Line Out: 200Hz – 20kHz + 3dBu • Mic Limiter Threshold: -35dBu ±3dB • Mic Limiter Range: ≥ 20dB • Max Input Level: -10dBu • Input Level: -45dBu nominal; -10dBu MAX • Headset Mic Voltage: 5V (Electret selectable) |
| Speaker Output | <ul style="list-style-type: none"> • Speaker Type: 1.6 x 2.8in oval • Load Impedance: 4Ω • Max Output Level before 1% Distortion: 18dBu ± 2dB • Total Harmonic Distortion (THD): < 0.5% THD at 1kHz • Max Speaker Level: 87dB ± 2dB SPL A Weighted at 3ft • Frequency Response: 100Hz – 10kHz ± 9dB |
| USB connector | USB type A |
| Front panel buttons | <ul style="list-style-type: none"> • MIC: Microphone ON/OFF button • Menu button • HDST: Headset ON/OFF button • Fn: Function button (not active) |
| Front panel rotary encoders | (5) Digital rotary encoders Operating level: 0dBu to + 18dBu, nominal, or -18dBu to +8dBu |
| Front panel touch screens | (2) 480 x 128 color TFT LED Touch Screen displays |
| Status LEDs | (2) Power supply status LEDs, (1) Arcadia status LED, (1) Volume level three color control LED array |

| Specification | Value |
|--|---|
| The Arcadia has two power supplies which can be used together to provide power redundancy. | |
| Power | <ol style="list-style-type: none"> 1. AC Mains input: 100-240V AC, 50-60Hz, 160W Max, IEC60320 C14 inlet. 2. DC Low Voltage Input: 12V DC +/- 5%, 12A |
| GPIO port | <p>(2) DB9F</p> <ul style="list-style-type: none"> • Relay contact type: SPDT • Relay quantity: 4 • Relay contact voltage rating: 30 VDC • Relay contact current rating: 1 A • Input type: Opto-Isolated • Input quantity: 2 • Input voltage range: 4 - 30 volts DC or AC • Input current: >=1.2mA required |
| 2-wire I/O | <p>(4) XLR-3F</p> <ul style="list-style-type: none"> • 2-wire I/O: Selectable RTS or Clear-Com mode, software controlled null, null depth >60dB at 1kHz • 2-wire Power On/Off: A/B, C/D paired- software controlled • 2-wire Output Voltage: 25 – 28 VDC, 560 mA per pair (A/B or C/D) • 2-wire Impedance: >10kΩ • 2-wire Operating Levels: -18dBu nominal (Clear-Com Mode), -12dBu nominal (RTS Mode), Headroom 18dB • 2-wire Frequency Response: 200 to 12kHz. ±3dB • 2-wire Total Harmonic Distortion (THD): < 0.1% THD at 1 kHz |

| Specification | Value |
|--|---|
| 4-wire I/O | (8) RJ45 <ul style="list-style-type: none"> • 4-wire I/O: Output Impedance >10kΩ, Input Impedance 200Ω + 10%, transformer isolated balanced input and output. • 4-wire Operating Levels: 0dBu Nominal, 18dBu headroom • Port 8 used for stage announce and program feed |
| Stage announce and program feed | (1) Cable assembly CAB-RJ45-PGM-SA provided. Connects to RJ45 (port 8 on the Station) <ul style="list-style-type: none"> • XLR-3F labeled PGM input • XLR-3M labeled SA output Program Input level control via rotary encoder. |
| DECT Sync IN/OUT | (2) RJ45 sync input and output |
| E1 Splitter/transceiver ports | (2) RJ45 (2) Fiber, to be used with SFP module Note: 2 splitter ports are active at any one time |
| LAN connectors | (2) RJ45 (2) SFP, to be used with Fiber or RJ45 SFP module All 4 LAN ports are fully user configurable, to be split between management, AES67 and Dante traffic. |
| Dimensions | 1 RU: h.44 x w.483 x d. 355 mm (1.75 x 19 x 14 inches) |
| Weight | Approx 3.3 kg (7.25 lb) |
| Frequency response - station to beltpack | |
| Arcadia to beltpack frequency response | <ul style="list-style-type: none"> • FreeSpeak II beltpacks: 200 Hz - 7.5 kHz • FreeSpeak Edge beltpacks: 200 Hz - 12 kHz |

16.2 Capacity

| Specification | Value |
|--|---|
| Number of transceivers supported by Arcadia | 42 in total <ul style="list-style-type: none"> • 32 IP transceivers (FreeSpeak II or FreeSpeak Edge) • E1 transceivers, 2 connected directly to the Arcadia, 10 via splitters |
| Number of FreeSpeak beltpacks per Arcadia | Up to 64 beltpacks in total, made up of either FreeSpeak II or FreeSpeak Edge beltpacks |
| Number of HelixNet user stations per Arcadia | Up to 128 made up of beltpacks, remote stations, speaker stations |
| Audio Channels | Max 100 |
| Channels enabled for use with HelixNet | Max 24 |
| Groups | Max 100 |
| GPIOs | 2 x GPI, 4 x GPO |

16.3 Network Specifications

| Specification | Value |
|--------------------------|---|
| AoIP Interface Protocols | <ul style="list-style-type: none"> • RTSP/SAP • AES67 • Dante |
| Audio Sampling | 24-bit Linear 48KHz |
| IP Addressing | <ul style="list-style-type: none"> • Static • DHCP |
| Network Compatibility | Layer 2 - Non-Routable |
| Quality of Service | DiffServ RFC2474 |
| IGMP | On (AoIP) |
| Multicast | On (AoIP) |
| Network Timing | PTPv2 (AoIP)/PTPv1 (Dante) |
| Perduplex Connection | <ul style="list-style-type: none"> • 1 x FS II IPT bandwidth usage: ~7 Mbps • 1 x FS Edge IPT: ~9.6 Mbps |
| Network Protocols | <ul style="list-style-type: none"> • Ethernet IPv4 Unicast Audio and Control • mDNS-Multicast Device Discovery |
| Network Ports | <ul style="list-style-type: none"> • Unicast: • Port 80 TCP - Web Interface, System Management, Expansion • Port 443 for HTTPS • Port 6001 UDP - AES67 Data • Port 15000 - 15256 UDP - AES67 Audio |
| | <p>Multicast:</p> <p>Port 5353 UDP - mDNS, Names, Discovery, Linking, Expansion, Dante (through various ports)</p> |

| Specification | Value | |
|-------------------------------|---|-----------------------------------|
| Network Jitter Tolerance | < 1µs required for RF Syncing of Transceivers | |
| Recommended Ethernet Switches | <ul style="list-style-type: none"> • Managed Ethernet Switch • 1000 Base - T ports for endpoints • 1000 Base IP Trunks between switches • QoS Configuration • Energy Efficient Ethernet bypass option • IGMP Snooping bypass option | |
| QoS Tags for AoIP | | |
| Clock | IEEE 1588-2008 Announce, Synch, Follow_Up, Delay_Req, Delay_Resp, Pdelay_Req, Pdelay_Resp and Pdelay_Resp_Follow_Up packets | EF (46) (Expedited Forwarding) |
| Media | RTP and RTCP media stream data | AF41 (34) (Assured Forwarding) |
| Best Effort | IEEE 1588-2008 signaling and management messages. Discovery and connection management messages. | DF (0) (Default Forwarding) |
| QoS Tags for Dante | | |
| High | Time Critical PTP Events | CS7 (56) |
| Medium | Audio, PTP | EF (46) (Expedited Forwarding) |
| Low | Reserved | CS1 (8) |
| None | Other Traffic | Best Effort (0) |

Appendix C: Spare Parts

| Part | Part Number |
|---|--|
| External power supply, 12VDC 150W | PSU-EXT-0001 |
| Split cable, RJ45 to PGM and SA | CAB-RJ45-PGM-SA |
| Fan plate assembly | T40020-1 |
| Rack ear (x1) | 272G162-SP |
| Encoder cap (x1) | 272G286-SP |
| Optional equipment | |
| Ethernet fiber modules*: 1 Gbps SM SXFIBER SFP 1 Gbps MM LXFIBER SFP 1 Gbps RJ45 SFP | SFP-SMFO-1G-LX SFP-MMFO-1G-SX SFP-RJ45-1G |
| FreeSpeak E1 fiber modules E1 Multi-Mode E1 Single-Mode | SFP-MMFO-100M-FX or HLI-MMFO SFP-SMFO-100M-LX or HLI-SMFO |
| Gooseneck microphones Gooseneck Mic 250mm/9" TRS Gooseneck Mic 450mm/18" TRS | GN-250-TRS GN-450-TRS |
| PSU Mounting Bracket | 272G048-SP |

*There is a detailed list of all Clear-Com SFPs (including range, wavelength and speed) on the [FreeSpeak II Knowledge Center](#).

18 Appendix D: Front Panel Menu Reference Tables

This chapter lists the front panel menu options. It contains the following sections:

- 18.1 Audio Settings 194
- 18.2 Host Settings 194
- 18.3 2 W Audio (A/B) (C/D) 195
- 18.4 Discovery 195
- 18.5 Transceiver 196
- 18.6 Networking 197
- 18.7 Administration 198

Note: Default values are shown in **bold**.

18.1 Audio Settings

| Level 1 | Level 2 | Level 3 | Level 4 |
|---------|-----------|------------------|---------------------------------------|
| Audio | Headset | Headset Limit | 8 to -12 dB/Off Default = 0 dB |
| | | Headset detect | Enabled/Disabled |
| | | HS Mic Type | Electret/ Dynamic |
| | | Sidetone Gain | 8 to -12 dB Default = -12 |
| | | Sidetone Control | Tracking/Non-Tracking/Disabled |
| | Gooseneck | GN Mic Type | Electret |
| | | | Dynamic |

18.2 Host Settings

| Level 1 | Level 2 | Level 3 | Level 4 |
|---------------|-----------|-------------------------|--|
| Host Settings | Host name | Edit | Press controller 4 to open a touchscreen keyboard. |
| | Display | Screen Brightness | High/ Medium /Low/Very Low |
| | | Screen Dimming | 1 to 15 minutes Default = 2 minutes |
| | | Touchscreen sensitivity | Low, Medium , High |

18.3 2 W Audio (A/B) (C/D)

| Level 1 | Level 2 | Level 3 | Level 4 |
|------------------|-----------------------|----------------|--|
| 2W Audio (A / B) | Interface | Power detected | Yes/No |
| | | Power | Enabled/ Disabled |
| | | Mode | Clear-Com /RTS |
| | 2W A | Nulling | The nulling function is only available if power is detected. |
| | 2W B | Nulling | as above |
| Audio (B / C) | Same as Audio (A / B) | | |

18.4 Discovery

| Level 1 | Level 2 | Level 3 | Level 4 |
|-----------|-----------------------|--------------------------|---------------------|
| Discovery | Discover FSII IP TCVR | Discovered FSII IP TCVRs | Register/Unregister |
| | Discover FSE TCVR | Discovered FSE TCVRs | Register/Unregister |

18.5 Transceiver

| Level 1 | Level 2 | Level 3 | Level 4 |
|-------------|---|----------------------|---|
| Transceiver | TCVR 1 ... XX View configured transceivers. Max: <ul style="list-style-type: none">E1; 10IP TCVRs; 6 | Version | |
| | | Label | |
| | | Cable Comp (E1 only) | 0 - 69 m , 70 - 139 m, 140 - 209 m, 210 - 279 m, 280 - 349 m, ... (increments of 70 m) up to 1540 - 1609 m |

18.6 Networking

| Level 1 | Level 2 | Level 3 | Level 4 |
|------------|--|-------------|---|
| Networking | Management | LAN Status | Up/Down |
| | | LAN Port | LAN Ports 1 - 4 |
| | | DHCP | Enabled/Disabled |
| | | IP Address | |
| | | Subnet mask | |
| | | MAC | |
| | AES67 (only visible if AES67 has been configured to its own LAN) | LAN Status | Up/Down |
| | Dante (only visible if Dante has been configured in the CCM) | | |
| | | LAN Port | By default Management /HelixNet is configured to LAN 1. AES67 is configured to LAN 2. This can be changed in the CCM. |
| | | DHCP | Enabled/Disabled |
| | | IP Address | |
| | | Subnet mask | |
| | | MAC | MAC address |

18.7 Administration

| Level 1 | Level 2 | Level 3 | Level 4 |
|----------------|-----------|----------------------|---|
| Administration | Beltpacks | Over The Air | Start OTA |
| | | BP Role List Sorting | Sort by Role Number /Alphabetical |
| | | Battery Type | Alkaline /NiMh (for use when not using the supplied Li-ion type batteries) |
| | Software | Current | View current version |
| | | Update | Use this to update the Arcadia using a USB stick. |
| | License | Connections | View connected ports |

| Level 1 | Level 2 | Level 3 | Level 4 |
|---------|---------|------------------|--|
| | | Licensed Ports | View licensed ports: <ul style="list-style-type: none"> • Total Ports • Wireless Ports • HelixNet ports • Dante Ports • Any Ports. Ports configured to Any will accept connections of any type: FreeSpeak, HelixNet or Dante |
| | Reset | Reboot | Press rotary 4 to reboot now |
| | | Reset to Default | Reset Base. When you reset the Base here, as well as system setup details (channels and roles), network details (IP addresses) are also reset. This is not the case when resetting the Base in the CCM. After resetting you must Add transceivers again. HelixNet connections revert to default config. |

| Level 1 | Level 2 | Level 3 | Level 4 |
|---------|--------------|--|---|
| | | Reset CCM Password | Press rotary 4 to reset CCM password to the default setting. |
| | Support Info | Generate | Insert USB |
| | Settings | Save Restore | Insert USB |
| | CCM Access | Username Default password | |
| | Hardware | Hw Info Hw Version BOM number PCB number Serial number Product number | Read only. Serial number here is the number of the electronic main board, not the Arcadia device. |

19 Appendix E: Regulatory Compliance (Regulatory Model: 1410)

Applicant Name: Clear-Com LLC

Applicant Address: 1301 Marina Village Pkwy, Suite 105, Alameda CA 94501, United States

Manufacturer Name: Clear-Com LLC

Manufacturer Address: 1301 Marina Village Pkwy, Suite 105, Alameda CA 94501, United States

Country of Origin: USA

Brand: Clear-Com

Caution: All products are compliant with regulatory requirements detailed in this document when the user follows all installation instructions and operating conditions per Clear-Com specifications

Caution: Use of accessories and peripherals other than those recommended by Clear-Com may void the product's compliance as well as the user's authority to operate the equipment.

19.1 FCC Notice

This device complies with Part 15 of the FCC rules. Operation is subject to the following two conditions: (1) This device may not cause harmful interference, and (2) This device must accept any interference received, including interference that may cause undesired operation.

NOTE: This equipment has been tested and found to comply with the limits for a Class A digital device, pursuant to Part 15 of the FCC rules. These limits are designed to provide reasonable protection against harmful interference when the equipment is operated in a commercial environment. This equipment generates, uses and can radiate radio frequency energy and, if not installed and used in accordance with the instruction manual, may cause harmful interference to radio communication. Operation of this equipment in a residential area is likely to cause harmful interference, in which case the user will be required to correct the interference at his own expense.

Changes or modifications not expressly approved by Clear-Com, LLC, an HM Electronics, Inc. company could void the user's authority to operate this equipment.

19.2 FCC/IC/EC RF Exposure Warning

- This product complies with FCC/IC/EC radiation exposure limits set forth for an uncontrolled environment.
- Produits Clear-Com sont conformes aux limites IC d'exposition aux rayonnements définies pour un environnement non contrôlé.
- This product may not be co-located or operated in conjunction with any other transceiver or transmitter.
- Ce produit ne peut pas être co-localisé ou utilisé en conjonction avec un autre émetteur-récepteur ou émetteur.
- To comply with FCC/IC/EC RF exposure requirements, the Antenna/Transceiver unit must be installed and operated at least 20 cm (8 inches) from any person.
- Produits Clear-Com doivent être installés et utilisés avec distance minimum de 20cm entre le radiateur et votre corps.

19.3 Industry Canada Compliance Statement

This Class[A] digital device complies with Canadian ICES-003.

Avis de conformité à la réglementation d'Industrie Canada

Cet appareil est conforme aux CNR d'Industrie Canada applicables aux appareils radio exempts de licence. L'exploitation est soumise aux deux conditions suivantes:

(1) cet appareil ne doit pas provoquer d'interférence, et

(2) cet appareil doit accepter toute interférence radioélectrique subie, même si l'interférence est susceptible d'en compromettre le fonctionnement.

Cet émetteur exempt de licence est équipé d'une antenne intégrée. Cet émetteur exempt de licence n'est pas autorisé à fonctionner avec une autre antenne.

Cet appareil numérique de la class[*] est conforme à la norme NMB-003 du Canada.

19.4 Korean Notice

A급 기기 (업무용 방송통신기자재)

이 기기는 업무용(A급)으로 전자파적합기기로서 판매자 또는 사용자는 이 점을 주의하시기 바라며, 가정외의 지역에서 사용하는 것을 목적으로 합니다.

19.5 European Union (CE mark)

The CE marking indicates compliance with the following directives and standards, whenever applicable to the product in question.

Directives:

- Radio Equipment Directive 2014/53/EU
- Electromagnetic Compatibility Directive 2014/30/EU
- Low Voltage Directive 2014/35/EU
- RoHS Directive 2011/65/EU, 2015/863/EU

Standards:

- EN55032
- EN55035
- IEC/EN62368-1
- EN300328
- EN301489
- EN50581



19.6 United Kingdom (UKCA Mark)

The UKCA (UK Conformity Assessed) marking is a new UK product marking that will be used for goods being placed on the market in Great Britain (England, Wales and Scotland). The UKCA marking alone cannot be used for goods placed on the Northern Ireland market, which require the CE marking or UK(NI) marking.



Warning:

This is a Class A product. In a domestic environment this product may cause radio interference in which case the user may be required to take adequate measures.

19.7 Electrical and Electronic Equipment (WEEE) Waste

The European Union (EU) WEEE Directive (2012/19/EU) places an obligation on producers (manufacturers, distributors and/or retailers) to take-back electronic products at the end of their useful life. The WEEE Directive covers most Clear-Com products being sold into the EU as of August 13, 2005. Manufacturers, distributors and retailers are obliged to finance the costs of recovery from municipal collection points, reuse, and recycling of specified percentages per the WEEE requirements.

Instructions for Disposal of WEEE by Users in the European Union

The symbol shown below is on the product or on its packaging which indicates that this product was put on the market after August 13, 2005 and must not be disposed of with other waste. Instead, it is the user's responsibility to dispose of the user's waste equipment by handing it over to a designated collection point for the recycling of WEEE. The separate collection and recycling of waste equipment at the time of disposal will help to conserve natural resources and ensure that it is recycled in a manner that protects human health and the environment. For more information about where you can drop off your waste equipment for recycling, please contact your local authority, your household waste disposal service or the seller from whom you purchased the product.

